

PART-A (1-20)

1. What are the order and degree respectively of the differential equation

$$\frac{d^2}{dx^2} \left\{ \left(\frac{d^2y}{dx^2} \right)^{-3/2} \right\} = 0 ?$$

- (A) 1, 4
 (B) 4, 1
 (C) 4, 4
 (D) 1, 1
2. Determine the radius of convergence for the following power series.

$$\sum_{n=1}^{\infty} \frac{n(-1)^n}{4^n} (x+3)^n$$

- (A) R = 2
 (B) R = 3
 (C) R = 4
 (D) R = 5
3. Let f(x) be a function such that $\lim_{x \rightarrow 0} \frac{f(x)}{x} = 1$, then find the values of a and b such that

$$\lim_{x \rightarrow 0} \frac{x(1+a \cos x) - b \sin x}{(f(x))^3} = 1$$

- (A) $\frac{5}{2}, \frac{3}{2}$
 (B) $\frac{-5}{2}, \frac{3}{2}$
 (C) $\frac{-5}{2}, \frac{-3}{2}$
 (D) $\frac{5}{2}, \frac{-3}{2}$

4. The series is : $\frac{2}{1^2} - \frac{3}{2^2} + \frac{4}{3^2} - \frac{5}{4^2} + \dots$
- (A) Conditional convergent
 (B) absolutely convergent
 (C) divergent
 (D) none of the above
5. If p and q are positive real numbers, then the series $\frac{2^p}{1^q} + \frac{3^p}{2^q} + \frac{4^p}{3^q} + \dots + \infty$ is convergent for ,
- (A) $p < q - 1$
 (B) $p < q + 1$
 (C) $p \geq q - 1$
 (D) $p \geq q + 1$
6. Let $\langle \mathbb{Z}, +, \dots \rangle$ be the ring of integers, define aRb iff $a - b$ is even, then the relation R is ,
- (A) reflexive only
 (B) reflexive and symmetric only
 (C) symmetric and transitive only
 (D) an equivalence relation
7. Let $f : [-1,1] \rightarrow \mathbb{R}$ be continuous Assume that $\int_{-1}^1 t(t)dt = 2$ Then $\lim_{n \rightarrow \infty} \int_{-1}^1 f(t) \sin^2(nt)dt$ is equal to
- (A) 0
 (B) 1
 (C) 2
 (D) does not exist
8. Let A be the matrix $a = \begin{bmatrix} a & c \\ 0 & a \end{bmatrix}$ with $a, c \in \mathbb{R}$ and $c \neq 0$ Then there is 2×2 matrix P such that PAP^{-1} is diagonal

- (A) for all values of a
 (B) for any value of a
 (C) if and only if $a = c$
 (D) if and only if $a = 0$
9. Let G be the group $G = Z_2 \times Z_3$. Then—
 (A) G is isomorphic to S_3
 (B) G is isomorphic to a subgroup of S_4
 (C) G is isomorphic to a proper subgroup of S_5
 (D) G is not isomorphic to a subgroup of S_n for all $n = 3$
10. Determine the value of a for which the solution tend to zero as $t \rightarrow \infty$ for differential equation
 $y'' - (2\alpha - 1)y' + \alpha(\alpha - 1)y = 0$
 (A) $\alpha > 1$
 (B) $\alpha < 0$
 (C) $\alpha > 0$
 (D) $\alpha < 1$
11. Evaluate $\lim_{(x,y) \rightarrow (0,0)} \frac{x^3 y}{x^6 + y^2}$
 (A) 1
 (B) 2
 (C) $\frac{1}{2}$
 (D) $\frac{1}{4}$
12. For the system of linear equations $AX = b$, where
- $$A = \begin{bmatrix} 1 & 1 & 1 \\ 2 & 2 & 2 \\ -1 & -1 & -1 \end{bmatrix}, b = \begin{bmatrix} 3 \\ 6 \\ 3 \end{bmatrix}, X = \begin{bmatrix} x_1 \\ x_2 \\ x_4 \end{bmatrix}$$

a true statements is–

- (A) A^{-1} exists
- (B) The system has unique solution
- (C) The system is consistent
- (D) None of (A), (B), (C) holds

13. The length of the arc of the curve $6xy = x^4 + 3$ from $x = 1$ to $x = 2$ is

- (A) $\frac{13}{12}$ unit
- (B) $\frac{17}{12}$ unit
- (C) $\frac{19}{12}$ unit
- (D) none of these

14. Solve $x \frac{d^2y}{dx^2} + (4x^2 - 1) \frac{dy}{dx} + 4x^3y = 2x^3$ and find it's general solution

- (A) $(c_1 + c_2x)e^{-x} + \frac{x}{2}$
- (B) $(c_1 + c_2x)e^{-x} - \frac{1}{2}$
- (C) $(c_1 + c_2x^2)e^{-x^2} - \frac{x}{2}$
- (D) $(c_1 + c_2x^2)e^{-x^2} + \frac{1}{2}$

15. Let V be the vector space of all 2×2 matrices over the field \mathbb{R} of real numbers and

$B = \begin{bmatrix} 1 & 2 \\ 0 & 3 \end{bmatrix}$. If $T: V \rightarrow V$ is a linear transformation defined by $T(A) = AB - BA$, then what is

the dimension of the kernel of T ?

- (A) 1
- (B) 2

(C) 3

(D) 4

16. If \vec{r} is an irrotational vector for any value of n , then find the value of n for this vector to be solenoidal. (\vec{r} is position vector of a point)

(A) 2

(B) 3

(C) -2

(D) -3

17. The series

$$\frac{x}{1+x^2} + \left(\frac{2^2 x}{1+2^3 x^2} - \frac{x}{1+x^2} \right) + \left(\frac{3^2 x}{1+3^3 x^2} - \frac{2^2 x}{1+2^3 x^2} \right) + \dots$$

(A) Converges uniformly

(B) Does not converges uniformly

(C) Diverges

(D) None of these

18. The value of $(\vec{b} \times \vec{c}) \cdot (\vec{a} \times \vec{d}) + (\vec{c} \times \vec{a}) \cdot (\vec{b} \times \vec{d}) + (\vec{a} \times \vec{b}) \cdot (\vec{c} \times \vec{d})$

is equals to

(A) 0

(B) 1

(C) 2

(D) -1

19. If f is continuous on $[a, b]$ and $k \in [m, M]$ where $m = \inf f$, $M = \sup f$ on $[a, b]$ then $\exists c \in [a, b]$ s.t. $f(c) = k$ is equals to

(A) $2k$

(B) k

(C) $3k$

(D) 0

20. If $f(x,y) = 2 + 2x + 2y - x^2 - y^2$ on the triangular region in the first quadrant bounded by the lines $x = 0$, $y = 0$, $y = 9 - x$ then the absolute maximum and minimum values respectively are
- (A) 61,-4
 (B) -61,4
 (C) 4,-61
 (D) 0,4

PART-B (21-40)

21. The area of a loop of the curve $xy^2 + (x+a)^2(x+2a) = 0$ is
- (A) $2a^2 \left(1 - \frac{1}{4}\pi\right)$
 (B) $2a^2 \left(1 + \frac{1}{4}\pi\right)$
 (C) $2a^3 \left(1 - \frac{1}{4}\pi^2\right)$
 (D) None of these
22. The curve passing through the points (x_1, y_1) and (x_2, y_2) which when rotated about the x-axis gives a minimum surface area as
- (A) Line
 (B) Curved
 (C) Catenary
 (D) All the above
23. Evaluate $\iint_D e^{xy} dA$ where $D = \{(x,y) | 1 \leq y \leq 2, y \leq x \leq y^3\}$
- (A) $e^4 - 2e$
 (B) $\frac{e^4 - 4e}{2}$

(C) $\frac{2e^4 - e}{2}$

(D) $\frac{e^4 - 2e}{3}$

24. The radius of convergence of power series $\sum_{n=1}^{\infty} \frac{(x-6)^n}{n^n}$

(A) 1

(B) 1/2

(C) 1/6

(D) ∞

25. Evaluate $\lim_{x \rightarrow 1} \left[\frac{\cos \frac{\pi}{2} x}{\log(1/x)} \right]$

(A) 1

(B) 0

(C) $\frac{\pi}{4}$

(D) $\frac{\pi}{2}$

26. Determine directional derivative for

$f(x, y, z) = \sin(yz) + \ln(n^2)$ at $(1, 1, \pi)$ in the direction $i + j - \hat{k}$ is

(A) $\frac{3 + \pi}{\sqrt{3}}$

(B) $\frac{3 - \pi}{\sqrt{3}}$

(C) $\frac{2 + \pi}{\sqrt{3}}$

(D) $\frac{2 - \pi}{\sqrt{3}}$

27. $(y^2z^3\cos x - 4x^3z)dx + 2z^3y \sin x dy + (3y^2z^2\sin x - x^4)dz$ is an exact differential of a function ϕ then
- (A) $\phi = x^2z^3 \sin x - x^4z + c$
 (B) $\phi = y^2z^3\sin x - x^4z + c$
 (C) $\phi = x^2z^2\sin x - x^3z^2 + c$
 (D) $\phi = y^2z^2 \sin x - x^3z^2 + c$
28. The solution of the differential equation $x \sin y/x dy = (y \sin y/x - x) dx$ is
- (A) $\log x = \cos y/x + c$
 (B) $\log y = \cos x/y + c$
 (C) $\log x = \cos x/y + c$
 (D) None of these
29. Let $f'(x) > 0$ and $f''(x) > 0$. then $f\left(\frac{x_1 + x_2}{2}\right) \geq$
- (A) $\frac{f(x_1) - f(x_2)}{2}$
 (B) $\frac{f(x_1) + 2f(x_2)}{2}$
 (C) $\frac{f(x_1) + f(x_2)}{2}$
 (D) $\frac{2f(x_1) + f(x_2)}{2}$
30. Solution of the initial-value problem $(2x\cos y + 3x^2y)dx + (x^3 - x^2\sin y - y)dy = 0$ is ,if $y(0) = 2$.
- (A) $x^2\cos y - x^3y + \frac{y^2}{2} = -2$

(B) $x^2 \cos y + x^3 y + \frac{y^2}{2} = -2$

(C) $x^2 \cos y + x^3 y - \frac{y^2}{2} = -2$

(D) None of these

31. Which of the following sequence of functions is not uniformly convergent on $(0, 1)$?

(A) $\frac{(1)^{n-1}}{n} x^n$

(B) $\frac{n^2 x}{1+n^4 x^2}$

(C) $\frac{x}{1+nx^2}$

(D) $x^{n-1}(1-x)$

32. If $A = \begin{bmatrix} 3 & -2 \\ 4 & -2 \end{bmatrix}$ satisfies the matrix equation $A^2 - kA + 2I = 0$, then what is the value of k ?

(A) 0

(B) 1

(C) 2

(D) 3

33. If $f(x) = \begin{cases} e^x + ax, & x < 0 \\ b(x-1)^2, & x \geq 0 \end{cases}$ is differentiable at $x = 0$, then (a, b) is

(A) $(-3, -1)$

(B) $(-3, 1)$

(C) $(3, 1)$

(D) $(3, -1)$

34. If $e^{ax}u(x)$ is a particular integral of $\frac{d^2y}{dx^2} - 2a\frac{dy}{dx} + a^2y = f(x)$ where a is a constant, then $\frac{d^2u}{dx^2}$ is

equal to :

(A) $f(x)$

(B) $f(x) e^{ax}$

(C) $f(x) e^{-ax}$

(D) $f(x) (e^{ax} + e^{-ax})$

35. The differential equation of a family of circles having the radius r and centre on the x -axis is :

(A) $y^2 \left[1 + \left(\frac{dy}{dx} \right)^2 \right] = r^2$

(B) $x^2 \left[1 + \left(\frac{dy}{dx} \right)^2 \right] = r^2$

(C) $(x^2 + y^2) \left[1 + \left(\frac{dy}{dx} \right)^2 \right] = r^2$

(D) $r^2 \left[1 + \left(\frac{dy}{dx} \right)^2 \right] = x^2$

36. It is given that $\sum_{n=0}^{\infty} a_n x^n$ converges at $x = 5$. Then the radius of convergence of the power

series $\sum_{n=0}^{\infty} a_n x^n$ is

(A) ≤ 5

(B) ≥ 5

(C) < 5

(D) > 5

37. Evaluate the following integrals by first reversing, the order of integration

$$\int_0^3 \int_{x^2}^9 x^3 e^{y^3} dy dx$$

(A) $\frac{1}{12} (e^{729} - 1)$

(B) $\frac{1}{12} (e^{-729} - 1)$

(C) $\frac{1}{12}(1 - e^{729})$

(D) $\frac{1}{12}(1 - e^{-729})$

38. If $f(x) = f(0) + xf'(0) + \frac{x^2}{2} f''(\theta x)$ and $f(x) = (1 - x)^{5/2}$, then the value of θ as $x \rightarrow 1$ is

(A) $\frac{3}{25}$

(B) $\frac{9}{25}$

(C) $\frac{4}{9}$

(D) $\frac{5}{9}$

39. If $\sum_{k=1}^{\infty} u_k$ be a series of real valued functions on a set E , and there exists positive numbers

$M_1, M_2 \dots$ with $\sum_{k=1}^{\infty} M_k < \infty$ such that $\sum_{k=1}^{\infty} u_k(x) \leq \sum_{k=1}^{\infty} M_k$ ($x \in E$), then

(A) $\sum_{k=1}^{\infty} u_k$ Converges uniformly on E .

(B) $\sum_{k=1}^{\infty} M_k$ is not a convergent sequence.

(C) $\sum_{k=1}^{\infty} u_k$ is not converges uniformly on E .

(D) $\sum_{k=1}^{\infty} M_k$ is not a Cauchy sequence.

40. By divergence theorem, value of $\int (lx^2 + my^2 + nz^2) ds$ taken over the sphere

$(x-a)^2 + (y-b)^2 + (z-c)^2 = p^2$, where

l, m, n , being the direction cosines of the normal to the sphere, is

- (A) $\frac{4\pi}{3}(a+b+c)p^3$
 (B) $\frac{3\pi}{4}(a+b+c)p^3$
 (C) $\frac{8\pi}{3}(a+b+c)p^3$
 (D) $\frac{3\pi}{8}(a+b+c)p^3$

PART-C (41-50)

41. Solve $xy_2 - y_1 - 4x^3y = -4x^5$, given that $y = e^{x^2}$ is a solution of the left hand side equated to zero.

42. (a) Discuss the continuity and discontinuity of the following functions

(i) $f(x) = \begin{cases} 1 & \text{if } x \text{ is rational} \\ 0 & \text{if } x \text{ is irrational} \end{cases}$ (Dirichlet's function)

(ii) $f(x) = \begin{cases} x & \text{if } x \text{ is rational} \\ 1-x & \text{if } x \text{ is irrational} \end{cases}$

(b) Given that the a, b, c are in A.P, then find the value of determinant $\begin{vmatrix} x+2 & x+3 & x+a \\ x+4 & x+5 & x+b \\ x+6 & x+7 & x+c \end{vmatrix}$

43. For what values of μ the equations

$$x + y + z = 1$$

$$x + 2y + 4z = \mu$$

$$x + 4y + 10z = \mu^2$$

have a solution and solve them completely in each case.

44. (a) Evaluate $\iint_S (a^2x^2 + b^2y^2 + c^2z^2)^{-\frac{1}{2}} dS$ over the surface of the ellipsoid $ax^2 + by^2 + cz^2 = 1$.

(b) Verify Stoke's theorem for $\mathbf{f} = (2y + z, x - z, y - x)$ taken over the triangle ABC cut from the plane $x + y + z = 1$ by the co-ordinate planes.

45. (a) If $a_{n+1} = \sqrt[k]{k + a_n}$, where a_1 and k are positive, show that the sequence $\{a_n\}$ is increasing or decreasing according as a_1 is less or greater than the positive root of the equation $x^k = x + k$, and has in either case this root as its limit.

i.e. prove that if $u_n = \sqrt[k]{k + u_{n-1}}$ and $u_1 > 0$ then $u_n \rightarrow \alpha$

- (b) Let $f(0) = 0$ and $f'(0) = 1$, then for a positive integer k , show that

$$\begin{aligned} \lim_{x \rightarrow 0} \frac{1}{x} \left\{ f(x) + f\left(\frac{x}{2}\right) + f\left(\frac{x}{3}\right) + \dots + f\left(\frac{x}{k}\right) \right\} \\ = 1 + \frac{1}{2} + \frac{1}{3} + \dots + \frac{1}{k} \end{aligned}$$

46. Let T be the linear operator on \mathbb{R}^3 defined by

$$T(x_1, x_2, x_3) = (3x_1 + x_3, -2x_1 + x_2, -x_1 + 2x_2 + 4x_3)$$

What is the matrix of T in the ordered basis $(\alpha_1, \alpha_2, \alpha_3)$ where $\alpha_1 = (1, 0, 1)$, $\alpha_2 = (-1, 2, 1)$ and $\alpha_3 = (2, 1, 1)$?

47. Prove that if P be a Sylow p -subgroups of G . let $x \in N(P)$ s.t. $o(x) = p^i$ then $x \in P$

48. (a) Let $A = \begin{pmatrix} a & b \\ c & d \end{pmatrix}$ be a 2×2 real matrix with $\det(A) = 1$, If A has no real eigenvalues then show that $(a + d)^2 < 4$.

- (b) Find the directional derivative of the function $f = x^2 - y^2 + 3z^2$ at the point $M(-1, 2, +1)$ in the direction of the line MN , where N is the point $(3, 0, 5)$.

49. If c is an interior point of the domain $[a, b]$ of a function f and is such that

(i) $f'(c) = f''(c) = f'''(c) = \dots = f^{(n-1)}(c) = 0$, and

(ii) $f^n(C)$ exists and is not zero.

While for n odd, $f(C)$ is not an extreme value, then show for n even, $f(C)$ is a maximum or minimum value according as $f^n(C)$ is negative or positive.

50. (a) Let $\theta : G \rightarrow G'$ be a homomorphism of G in G' with G' abelian. Let H be a subgroup of G containing $\text{Ker } \theta$. Show that H is normal in G .

(b) If V be the vector space of all square $n \times n$ matrices over a field F and $W = \{ A \in V : AM = MA \}$, for a given matrix M , then show W is a subspace of $V(F)$.

ANSWER KEY

| | | | | | | | | | | | | | | | |
|-------|----|----|----|----|----|----|----|----|----|----|----|----|----|----|----|
| Ques. | 1 | 2 | 3 | 4 | 5 | 6 | 7 | 8 | 9 | 10 | 11 | 12 | 13 | 14 | 15 |
| Ans. | B | C | C | A | A | D | A | B | A | B | C | D | B | D | B |
| Ques. | 16 | 17 | 18 | 19 | 20 | 21 | 22 | 23 | 24 | 25 | 26 | 27 | 28 | 29 | 30 |
| Ans. | D | B | A | B | C | A | C | B | D | D | B | B | A | C | C |
| Ques. | 31 | 32 | 33 | 34 | 35 | 36 | 37 | 38 | 39 | 40 | | | | | |
| Ans. | B | B | B | C | A | D | A | B | A | C | | | | | |

HINTS AND SOLUTIONS

1.(B) Here given differential equation is

$$\frac{d^2}{dx^2} \left\{ \left(\frac{d^2 y}{dx^2} \right)^{-3/2} \right\} = 0$$

$$\therefore \frac{d}{dx} \left(\frac{d^2 y}{dx^2} \right)^{-3/2}$$

$$= -\frac{3}{2} \left(\frac{d^2 y}{dx^2} \right)^{-5/2} \frac{d^3 y}{dx^3}$$

$$\Rightarrow \frac{d^2}{dx^2} \left\{ \left(\frac{d^2 y}{dx^2} \right)^{-3/2} \right\}$$

$$= -\frac{3}{2} \left\{ \left(-\frac{5}{2} \right) \left(\frac{d^2 y}{dx^2} \right)^{-7/2} \left(\frac{d^3 y}{dx^3} \right)^2 + \left(\frac{d^2 y}{dx^2} \right)^{-5/2} \frac{d^4 y}{dx^4} \right\}$$

$$\text{If } \frac{d^2}{dx^2} \left\{ \left(\frac{d^2 y}{dx^2} \right)^{-3/2} \right\} = 0$$

$$\Rightarrow \frac{5}{2} \left(\frac{d^3 y}{dx^3} \right)^2 = \left(\frac{d^2 y}{dx^2} \right) \frac{d^4 y}{dx^4}$$

\therefore order = 4 and degree = 1

2.(C) We know that this power series will converge for $x = -3$. To determine the remainder of the x 's for which we'll get convergence we can use any of the tests. After application of the test that we choose to work with we will arrive at condition(s) on x that we can use to determine which values of x for which the power series will converge and for which values for x the power series will diverges. From this, we can get the radius of convergence and most of the interval of convergence (with the possible exception of the endpoints).

With all that said, the best tests to use here are almost always the ratio or root test. Most of the power series that we'll be looking at are set up for one or the other. In this case we'll use the ratio test.

$$L = \lim_{n \rightarrow \infty} \left| \frac{(-1)^{n+1} (n+1)(x+3)^{n+1}}{4^{n+1}} \cdot \frac{4^n}{(-1)^n (n)(x+3)^n} \right|$$

$$= \lim_{n \rightarrow \infty} \left| \frac{-(n+1)(x+3)}{4n} \right|$$

Before going any farther with the limit let's notice that since x is not dependent on the limit and so it can be factored out of the limit. We will need to keep the absolute value bars on it since we need to make sure everything stays positive and x could be a value that will make things negative.

The limit is then,

$$L = |x+3| \lim_{n \rightarrow \infty} \frac{n+1}{4n}$$

$$= \frac{1}{4}|x+3|$$

So, the ratio test tells us that if $L < 1$ the series will converge, if $L > 1$ the series will diverge. So, we have,

$$= \frac{1}{4}|x+3| < 1 \Rightarrow |x+3| < 4 \quad \text{series converges}$$

$$= \frac{1}{4}|x+3| > 1 \Rightarrow |x+3| > 4 \quad \text{series diverges}$$

We'll deal with the $L = 1$ case in a bit. Notice that we now have the radius of convergence for this power series. These are exactly the conditions required for the radius of convergence. The radius of convergence for this power series is

$R = 4$.

3.(C) Since, $\lim_{x \rightarrow 0} \frac{x(1+a+\cos x) - b \sin x}{\{f(x)\}^3} = 1$

$$\Rightarrow \lim_{x \rightarrow 0} \frac{x \left(1+a \left(1 - \frac{x^2}{2!} + \frac{x^4}{4!} - \dots \right) \right) - b \left(x - \frac{x^3}{3!} + \frac{x^5}{5!} - \dots \right)}{\{f(x)\}^3} = 1$$

$$\Rightarrow \lim_{x \rightarrow 0} \frac{x(1+a-b) + x^3 \left(-\frac{a}{2!} + \frac{b}{3!} \right) + x^5 \left(\frac{a}{4!} - \frac{b}{5!} \right) + \dots}{\{f(x)\}^3} = 1$$

$$\Rightarrow \lim_{x \rightarrow 0} \frac{\frac{(1+a-b)}{x^2} + \left(-\frac{a}{2!} + \frac{b}{3!} \right) + x^2 \left(\frac{a}{4!} - \frac{b}{5!} \right) + \dots}{\left\{ \frac{f(x)}{x} \right\}^3} = 1$$

\therefore R.H.S is finite then L.H.S is also finite, then

$$1 + a - b = 0 \text{ and } -\frac{a}{2!} + \frac{b}{3!} = 1$$

$$\Rightarrow -3a + b = 6$$

then we get, $a = -5/2$ and $b = -3/2$.

4.(A) Let the given series is denoted by ΣU_n

$$\begin{aligned} \text{then } \Sigma |U_n| &= \frac{2}{1^2} + \frac{3}{2^2} + \frac{4}{3^2} + \frac{5}{4^2} + \dots + \frac{n+1}{n^2} \\ &= \Sigma v_n \quad (\text{say}) \end{aligned}$$

Compare this series Σv_n with the auxiliary series

$$\Sigma w_n = \Sigma 1/n$$

$$\begin{aligned} \text{Then } \lim_{n \rightarrow \infty} \frac{v_n}{w_n} &= \lim_{n \rightarrow \infty} \left[\frac{n+1}{n^2} \times \frac{n}{1} \right] \\ &= \lim_{n \rightarrow \infty} \left(1 + \frac{1}{n} \right) \\ &= 1 \end{aligned}$$

which is a finite quantity.

Hence Σu_n and Σw_n are either both convergent or both divergent. But $\Sigma w_n = \Sigma (1/n)$ is

divergent as the series $\Sigma \frac{1}{n^p}$ is divergent if $p = 1$.

Hence the series Σv_n is divergent.

Also in the series Σu_n we find that its terms are alternately positive and negative, its terms

are continually decreasing and $\lim_{n \rightarrow \infty} u_n = \lim_{n \rightarrow \infty} \left(\frac{n+1}{n^2} \right) = \lim_{n \rightarrow \infty} \left(\frac{1}{n} + \frac{1}{n^2} \right) = 0$

Thus all conditions of Leibnitz's test are satisfied and as such Σu_n is convergent.

Hence the given series is conditionally convergent.

5.(A) Here, given series Σu_n is

$$\frac{2^p}{1^q} + \frac{3^p}{2^q} + \frac{4^p}{3^q} + \dots$$

Let
$$U_n = \frac{(n+1)^p}{n^q} = \left(\frac{n+1}{n}\right)^p \cdot \frac{1}{n^{q-p}}$$

$$= n^{p-q} \left(1 + \frac{1}{n}\right)^p$$

Take
$$V_n = n^{p-q} + \frac{1}{n^{q-p}}$$

$$\therefore \lim_{n \rightarrow \infty} \frac{U_n}{V_n} = \lim_{n \rightarrow \infty} \left(1 + \frac{1}{n}\right)^p$$

$$= 1, \text{ finite and non-zero.}$$

\therefore By P series test

$$\sum V_n = \frac{1}{n^{q-p}}$$
 is convergent if $q - p > 1$

or
$$p < q - 1$$

when $\sum U_n$ is convergent when $p < q - 1$, then $\sum U_n$ is also convergent when $p < q - 1$.

6.(D) Here, it is given that $\langle Z, +, \cdot \rangle$ be the ring of integers defined by aRb if $a - b$ is even.

Let $a, b, c \in Z$,

then, $aRa \Rightarrow a - a$ is even $\forall a \in Z$

$\therefore R$ is reflexive.

$a - b$ is even then $b - a$ is also even.

Then $aRb \Rightarrow bRa \forall a, b \in Z$

$\therefore R$ is symmetric.

and if $(a - b)$ and $(b - c)$ both are even, then

$$(a - b) + (b - c) \text{ are even.}$$

$\Rightarrow (a - c)$ is also even.

Then aRb and $aRc \forall a, b, c \in Z$

$\therefore R$ is transitive.

Thus R is an equivalence relation.

7. (A) Since firstly let $I = \int_{-1}^1 f(t) \sin^2(nt) dt$

$$\begin{aligned} \text{now } I &= \sin^2 nt \int_{-1}^1 \int_{-1}^1 f(t) dt - \int_{-1}^1 2 \sin nt \cos nt \cdot n \int_{-1}^1 f(t) dt dt \\ &= \sin^2 nt [2]_{-1}^1 - \int_{-1}^1 \sin 2nt \cdot 2x dt \\ &= 2 \sin^2 nt \Big|_{-1}^1 + 2n \left[\frac{\cos 2nt}{2n} \right]_{-1}^1 \\ &= 0 \end{aligned}$$

$$\text{Lim } \int_{-1}^1 f(t) \sin^2(nt) dt = 0$$

8. (B) Since $A = \begin{bmatrix} a & c \\ 0 & a \end{bmatrix}$

for eigenvalues of A

the characteristic equation is given by

$$|A - \lambda I| = 0$$

$$\begin{vmatrix} a - \lambda & c \\ 0 & a - \lambda \end{vmatrix} = 0$$

$$\Rightarrow (a - \lambda)^2 = 0$$

the eigenvalues are $\lambda = a, a$

now let $[x_1 \ x_2]^T$ be the eigenvector correspond to eigenvalue

$$\text{so } \begin{bmatrix} 0 & c \\ 0 & 0 \end{bmatrix} \begin{bmatrix} x_1 \\ x_2 \end{bmatrix} = \begin{bmatrix} 0 \\ 0 \end{bmatrix}$$

$$x_2 = 0$$

but x_1 arbitrary

⇒ the eigen vector corresponding to both eigenvalues is linearly independent thus we could not find any matrix P such that PAP^{-1} is diagonal for any value of a.

9.(A) Since $G = \square_2 \times \square_3$

Hence G is cyclic group of order 6 and $O(S_3) = 6$

and we know that permutation groups are cyclic for $(n \leq 3)$

⇒ G and S_3 are both cyclic group of order 6

⇒ They are isomorphic to each other

10.(B) Given differential equation

$$y'' - (2\alpha - 1)y' + \alpha(\alpha - 1)y = 0$$

its auxiliary equation is

$$r^2 - (2\alpha - 1)r + \alpha(\alpha - 1) = (r - \alpha)(r + 1 - \alpha) = 0$$

and its roots are $r_1 = \alpha$ $r_2 = \alpha - 1$

Hence the general solution is

$$y(t) = c_1 e^{\alpha t} + c_2 e^{(\alpha-1)t}$$

as $t \rightarrow \infty$ it is possible that $y \rightarrow 0$

only for $\alpha < 0$

11.(C) Let $L = \lim_{(x,y) \rightarrow (0,0)} \frac{x^3 y}{x^6 + y^2}$

Along the path $y = x$ we have

$$\begin{aligned} \lim_{(x,y) \rightarrow (0,0)} \frac{x^3 y}{x^6 + y^2} &= \lim_{(x,y) \rightarrow (0,0)} \frac{x^3 x}{x^6 + x^2} \\ &= \lim_{(x,y) \rightarrow (0,0)} \frac{x^4}{x^6 + x^2} \\ &= \lim_{(x,y) \rightarrow (0,0)} \frac{x^2}{x^4 + 1} = 0 \end{aligned}$$

Along path $y = x^3$

$$\begin{aligned} \lim_{(x,y) \rightarrow (0,0)} \frac{x^3}{x^6 + y^2} &= \lim_{(x,y) \rightarrow (0,0)} \frac{x^3, x^3}{x^6 + (x^3)^2} = \lim_{(x,y) \rightarrow (0,0)} \frac{x^6}{2x^6} \\ &= \frac{1}{2} \end{aligned}$$

12.(D) Let $A = \begin{bmatrix} 1 & 1 & 1 \\ 2 & 2 & 2 \\ -1 & -1 & -1 \end{bmatrix}$

$$= \begin{bmatrix} 1 & 1 & 1 \\ 0 & 0 & 0 \\ 0 & 0 & 0 \end{bmatrix} \text{ by } \begin{array}{l} R_2 \rightarrow R_2 - 2R_1 \\ R_3 \rightarrow R_3 + R_1 \end{array}$$

$\Rightarrow \rho(A) = 1$

$$[A : b] = \begin{bmatrix} 1 & 1 & 1 & : & 3 \\ 2 & 2 & 2 & : & 6 \\ -1 & -1 & -1 & : & 3 \end{bmatrix}$$

$$= \begin{bmatrix} 1 & 1 & 1 & : & 3 \\ 0 & 0 & 0 & : & 0 \\ 0 & 0 & 0 & : & 6 \end{bmatrix} \text{ by } \begin{array}{l} R_2 \rightarrow R_2 - 2R_1 \\ R_3 \rightarrow R_3 + R_1 \end{array}$$

$\therefore \rho([A : b]) = 2$

$\rho(A) = 1 \Rightarrow A$ is a singular matrix

$\Rightarrow A^{-1}$ does not exist

$\rho(A) \neq \rho([A : b])$

\Rightarrow The system is not consistent.

13.(B) Here it is given that curve $6xy = x^4 + 3$ from $x = 1$ to $x = 2$

\therefore From curve $6xy = x^4 + 3$

$$y = \frac{x^4}{6x} + \frac{3}{6x}$$

$$y = \frac{x^3}{6} + \frac{1}{2x}$$

$$\therefore \frac{dy}{dx} = \frac{3x^2}{6} - \frac{1}{2x^2}$$

$$\frac{dy}{dx} = \frac{x^2}{2} - \frac{1}{2x^2}$$

$$\therefore \text{Required length of arc } S = \int_1^2 \sqrt{1 + \left(\frac{dy}{dx}\right)^2} dx$$

$$= \int_1^2 \sqrt{1 + \frac{1}{4} \left(x^2 - \frac{1}{x^2}\right)^2} dx$$

$$= \int_1^2 \sqrt{\frac{4 + \left(x^2 - \frac{1}{x^2}\right)^2}{4}} dx$$

$$= \int_1^2 \frac{1}{2} \sqrt{4 + x^4 + \frac{1}{x^4} - 2} dx$$

$$= \frac{1}{2} \int_1^2 \sqrt{x^4 + \frac{1}{x^4} + 2} dx$$

$$= \frac{1}{2} \int_1^2 \sqrt{\left(x^2 + \frac{1}{x^2}\right)^2} dx$$

$$= \frac{1}{2} \int_1^2 \left(x^2 + \frac{1}{x^2}\right) dx$$

$$= \frac{1}{2} \left[\frac{x^3}{3} - \frac{1}{x} \right]_1^2$$

$$= \frac{1}{2} \left[\left(\frac{8}{3} - \frac{1}{2}\right) - \left(\frac{1}{3} - 1\right) \right]$$

$$= \frac{1}{2} \left[\left(\frac{16-3}{6}\right) - \left(\frac{1-3}{3}\right) \right]$$

$$= \frac{1}{2} \left[\frac{13}{6} + \frac{2}{3} \right] = \frac{1}{2} \times \left(\frac{13+4}{6}\right)$$

$$= \frac{17}{12} \text{unit}$$

14.(D) $P = \frac{4x^2 - 1}{x}, Q = 4x^2, X = 2x^2.$

In the transformed differential, choose z in such a way that

$$Q_1 = \frac{Q}{(dz/dx)^2} = 1 \quad \text{or} \quad \frac{4x^2}{(dz/dx)^2} = 1$$

$$\Rightarrow dz/dx = 2x \Rightarrow z = x^2 \quad \text{and} \quad d^2z/dx^2 = 2$$

The reduced differential is $\frac{d^2y}{dz^2} + \frac{2 + \left(\frac{4x^2 - 1}{x}\right) \cdot 2x}{4x^2} \cdot \frac{dy}{dz} + y = \frac{2x^2}{(2x)^2}$

or $\frac{d^2y}{dz^2} + 2 \frac{dy}{dz} + y = \frac{1}{2}$

or $(D^2 + 2D + 1)y = \frac{1}{2}$ where $D \equiv d/dz.$

A.E. is $(m + 1)^2 = 0$, giving $m = -1$ two times.

$$\Rightarrow \text{C.F} = (C_1 + C_2 z) e^{-z}. \quad \text{Also P.I.} = \frac{1}{(1+D)^2} \left(\frac{1}{2} \right) = \frac{1}{2}.$$

Hence the General solution is given by

$$y = \text{C.F.} + \text{P.I.} = (C_1 + C_2 z) e^{-z} + \frac{1}{2} = (C_1 + C_2 x^2) e^{-x^2} + \frac{1}{2}.$$

15.(B) Null space or kernel of linear transformation T

Let $U(F)$ and $V(F)$ be two vector spaces and let T be a linear transformation from U to V , then the null space of T written as $N(T)$ is the set of all vectors α in U such that $T(\alpha) = 0$ (zero vector of V)

$$\text{Thus } N(T) = \{\alpha \in U : T(\alpha) = 0 \in V\}$$

The null space of T is also called the kernel of T .

Now the standard basis for a vector space of all 2×2 matrices over field \mathbb{R} of real number is $\{e_1, e_2, e_3, e_4\}$

$$\text{where } e_1 = \begin{pmatrix} 1 & 0 \\ 0 & 0 \end{pmatrix}, e_2 = \begin{pmatrix} 0 & 1 \\ 0 & 0 \end{pmatrix}$$

$$e_3 = \begin{pmatrix} 0 & 0 \\ 1 & 0 \end{pmatrix}, e_4 = \begin{pmatrix} 0 & 0 \\ 0 & 1 \end{pmatrix}$$

$$\text{we have, } T(A) = AB - BA, \text{ where } B = \begin{pmatrix} 1 & 2 \\ 0 & 3 \end{pmatrix}$$

$$\begin{aligned} \text{so, } T(e_1) &= \begin{pmatrix} 1 & 0 \\ 0 & 0 \end{pmatrix} \begin{pmatrix} 1 & 2 \\ 0 & 3 \end{pmatrix} - \begin{pmatrix} 1 & 2 \\ 0 & 3 \end{pmatrix} \begin{pmatrix} 1 & 0 \\ 0 & 0 \end{pmatrix} \\ &= \begin{pmatrix} 1 & 2 \\ 0 & 0 \end{pmatrix} - \begin{pmatrix} 1 & 0 \\ 0 & 0 \end{pmatrix} \\ &= \begin{pmatrix} 0 & 2 \\ 0 & 0 \end{pmatrix} \end{aligned}$$

Thus, $T(e_1)$, $T(e_2)$, $T(e_3)$ and $T(e_4)$ span the range of T

Null space

let $\begin{pmatrix} a & b \\ c & d \end{pmatrix} \in$ null space of T

$$\Rightarrow T \begin{pmatrix} a & b \\ c & d \end{pmatrix} = \begin{pmatrix} 0 & 0 \\ 0 & 0 \end{pmatrix}$$

$$\Rightarrow \begin{pmatrix} a & b \\ c & d \end{pmatrix} \begin{pmatrix} 1 & 2 \\ 0 & 3 \end{pmatrix} - \begin{pmatrix} 1 & 2 \\ 0 & 3 \end{pmatrix} \begin{pmatrix} a & b \\ c & d \end{pmatrix} = \begin{pmatrix} 0 & 0 \\ 0 & 0 \end{pmatrix}$$

$$\Rightarrow \begin{pmatrix} a & 2a+3b \\ c & 2c+3d \end{pmatrix} - \begin{pmatrix} a+2c & b+2d \\ 3c & 3d \end{pmatrix} = \begin{pmatrix} 0 & 0 \\ 0 & 0 \end{pmatrix}$$

$$\Rightarrow \begin{pmatrix} -2c & 2a+2b-2d \\ -2c & 2c \end{pmatrix} = \begin{pmatrix} 0 & 0 \\ 0 & 0 \end{pmatrix}$$

$$\Rightarrow 2c = 0; 2a + 2b - 2d = 0$$

This system of equations have two independent variables hence, it have two independent solutions.

⇒ The dimension of null space is 2.

16.(D) $\text{div } r^n \mathbf{r} = \nabla \cdot (r^n \mathbf{r})$

$$\begin{aligned} &= \left(\hat{i} \frac{\partial}{\partial x} + \hat{j} \frac{\partial}{\partial y} + \hat{k} \frac{\partial}{\partial z} \right) \cdot \{ r^n (\hat{i}x + \hat{j}y + \hat{k}z) \} \\ &= \frac{\partial}{\partial x} (r^n x) + \frac{\partial}{\partial y} (r^n y) + \frac{\partial}{\partial z} (r^n z) \\ &= r^n + xn r^{n-1} \frac{\partial r}{\partial x} + r^n + yn r^{n-1} \frac{\partial r}{\partial y} + r^n + zn r^{n-1} \frac{\partial r}{\partial z} \\ &= 3r^n + n r^{n-1} \left\{ x \frac{\partial r}{\partial x} + y \frac{\partial r}{\partial y} + z \frac{\partial r}{\partial z} \right\} \\ &= 3r^n + n r^{n-1} \left\{ x \cdot \frac{x}{r} + y \cdot \frac{y}{r} + z \cdot \frac{z}{r} \right\} \\ &= 3r^n + n r^{n-1} \left(\frac{x^2 + y^2 + z^2}{r} \right) \\ &= 3r^n + n r^{n-1} \cdot r \\ &= 3r^n + nr^n = (3 + n) r^n \end{aligned}$$

i.e., $\text{div } r^n \mathbf{r} = (n + 3) r^n$ which is zero if $n = -3$.

Thus $\text{div } r^n \mathbf{r} = 0$ only if $n = -3$

This shows that $r^n \mathbf{r}$ is solenoidal vector only if $n = -3$.

17.(B) Here

$$u_1(x) = \frac{x}{1+x^2}$$

$$u_2(x) = \frac{2^2 x}{1+2^3 x^2} - \frac{x}{1+x^2}$$

$$u_3(x) = \frac{3^2 x}{1+3^2 x^2} - \frac{2^2 x}{1+2^3 x^2}$$

$$u_n(x) = \frac{n^2 x}{1+n^3 x^2} - \frac{(n-1)^2 x}{1+(n-1)^3 x^2}$$

Adding $f_n(x) = \frac{n^2 x}{1+n^3 x^2}$

Hence $f(x) = \lim_{n \rightarrow \infty} f_n(x) = 0, \forall x \in [0,1]$

Now, $M_n = \sup\{|f_n(x) - f(x)|; x \in [0,1]\}$

$$= \sup\left\{\frac{n^2 x}{1+n^3 x^2}; x \in [0,1]\right\}$$

$$\geq \frac{n^2 \cdot \frac{1}{n^{3/2}}}{1+n^3 \cdot \frac{1}{n^3}} = \frac{\sqrt{n}}{2} \quad \left[\text{taking } x = \frac{1}{n^{3/2}} \right]$$

$\rightarrow \infty$ as $n \rightarrow \infty$

Since M_n does not tend to zero as $n \rightarrow \infty$, thus, the series is not uniformly convergent on $[0, 1]$ by M_n -test.

Here 0 is a point of non-uniform convergence.

18.(A) we have

$$(\vec{b} \times \vec{c}) \cdot (\vec{a} \times \vec{d}) = \begin{vmatrix} \vec{b} \cdot \vec{a} & \vec{b} \cdot \vec{d} \\ \vec{c} \cdot \vec{a} & \vec{c} \cdot \vec{d} \end{vmatrix}$$

$$= (\vec{b} \cdot \vec{a})(\vec{c} \cdot \vec{d}) - (\vec{c} \cdot \vec{a})(\vec{b} \cdot \vec{d}) \quad (1)$$

similarly

$$(\vec{c} \times \vec{a}) \cdot (\vec{b} \times \vec{d}) = \begin{vmatrix} \vec{c} \cdot \vec{b} & \vec{c} \cdot \vec{d} \\ \vec{a} \cdot \vec{b} & \vec{a} \cdot \vec{d} \end{vmatrix}$$

$$= (\vec{c} \cdot \vec{b})(\vec{a} \cdot \vec{d}) - (\vec{a} \cdot \vec{b})(\vec{c} \cdot \vec{d}) \quad (2)$$

and

$$\begin{aligned}
 (\vec{a} \times \vec{b}) \cdot (\vec{c} \times \vec{d}) &= \begin{vmatrix} \vec{a} \cdot \vec{c} & \vec{a} \cdot \vec{d} \\ \vec{b} \cdot \vec{c} & \vec{b} \cdot \vec{d} \end{vmatrix} \\
 &= (\vec{a} \cdot \vec{c})(\vec{b} \cdot \vec{d}) - (\vec{a} \cdot \vec{d})(\vec{b} \cdot \vec{c}) \quad (3)
 \end{aligned}$$

Adding (1), (2) and (3) we get

$$(\vec{b} \times \vec{c}) \cdot (\vec{a} \times \vec{d}) + (\vec{c} \times \vec{a}) \cdot (\vec{b} \times \vec{d}) + (\vec{a} \times \vec{b}) \cdot (\vec{c} \times \vec{d}) = 0$$

- 19.(B)** If f is continuous on $[a,b]$ it is bounded and attains its boundary on $[a,b]$. Let $m = f(x_1)$, $M = f(x_2)$ where $x_1, x_2 \in [a,b]$ if $x_1 = x_2$ then f is constant on $[a,b]$ then the result is evident let $x_1 < x_2$. since $[x_1, x_2] \subset [a,b]$ f is continuous on $[x_1, x_2]$ and so $\exists c \in [x_1, x_2] \subset [a,b]$ s.t., $f(c) = k$. the result similarly follows if $x_1 > x_2$.

Since every number lying between m and M is a member of the range set of f on $[a,b]$, then we have $f(c) = k$.

- 20.(C)** Since f is differentiable, the only places where f can assume these values which are points inside the triangle (Figure), where $f_x = f_y = 0$ and points on the boundary are:

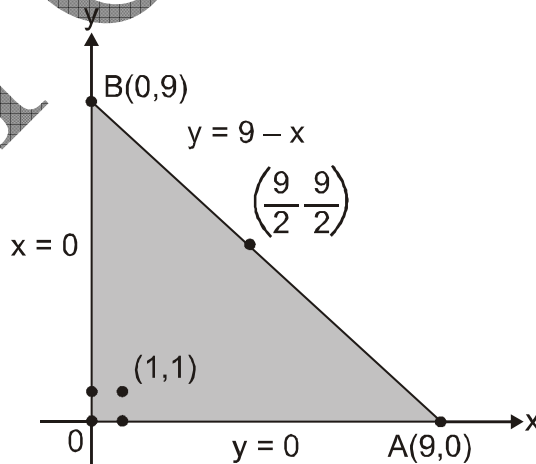

(a) Interior points. For these we have

$$f_x = 2 - 2x = 0, f_y = 2 - 2y = 0,$$

yielding the single point $(x,y) = (1,1)$. The value is

$$f(1,1) = 4.$$

(b) Boundary points. We take the triangle one side at a time :

(i) On the segment OA, $y = 0$. The function

$$f(x,y) = f(x,0) = 2 + 2x - x^2$$

may now be regarded as a function of x defined on the closed interval $0 \leq x \leq 9$. Its extreme values may occur at the endpoints

$$x = 0 \quad \text{where} \quad f(0,0) = 2$$

$$x = 9 \quad \text{where} \quad f(9,0) = 2 + 18 - 81 = -61$$

and at the interior points where $f'(x,0) = 2 - 2x = 0$. The only interior point where $f'(x,0) = 0$ is $x = 1$. where

$$f(x,0) = f(1,0) = 3$$

(ii) On the segment OB, $x = 0$ and

$$f(x,y) = f(0,y) = 2 + 2y - y^2$$

We know from the symmetry of f in x and y and from the analysis we just carried out that the candidates on this segment are

$$f(0,0) = 2, \quad f(0,9) = -61, \quad f(0,1) = 3.$$

(iii) We have already accounted for the values of f at the endpoints of AB, so we need only look at the interior points of AB. With $y = 9 - x$, we have

$$f(x,y) = 2 + 2x + 2(9 - x) - x^2 - (9 - x)^2 = -61 + 18x - 2x^2$$

Setting $f'(x, 9 - x) = 18 - 4x = 0$ gives

$$x = \frac{18}{4} = \frac{9}{2}.$$

At this value of x ,

$$y = 9 - \frac{9}{2} = \frac{9}{2} \quad \text{and} \quad f\left(\frac{9}{2}, \frac{9}{2}\right) = \frac{41}{2}.$$

We list all the candidates : 4, 2, - 61, 3, - (41/2). The maximum is 4, which f assumes at (1,1). The minimum is -61, which f assumes at (0,9) and (9,0).

- 21.(A)** The curve is symmetrical about x – axis. putting $y = 0$ we get $x = -a$, and $x = -2a$
The loop is formed between
 $x = -a$ and $x = -2a$

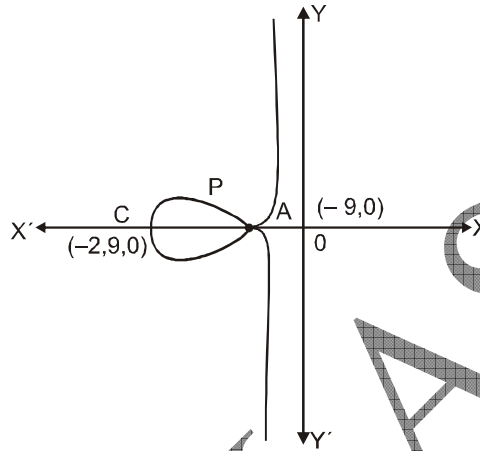

To find the area of the loop, we first shift the origin to the point $(-a, 0)$, the equation of the curve then becomes

$$(x - a)y^2 + \{(x - a) + a\}^2 + (x - a + 2a) = 0$$

$$\Rightarrow y^2 (x - a) + x^2 (x + a) = 0$$

$$\Rightarrow y^2 = \frac{x^2 (a + x)}{a - x} \quad (1)$$

Now the origin being at the point A, the new limits for the loop are $x = -a$ to $x = 0$

\therefore required area of the loop = 2 x area CPA

$$= 2 \int_{-a}^0 y \, dx$$

$$= 2 \int_{-a}^0 \left[-x \sqrt{\frac{a+x}{a-x}} \right] dx$$

$$= 2 \int_{-a}^0 \frac{-x(a+x)}{\sqrt{a^2-x^2}} dx$$

put $x = -a \sin \theta$

$$dx = -a \cos \theta d\theta$$

$$= 2 \int_{\pi/2}^0 \frac{-(-a \sin \theta)(a - a \sin \theta)(-a \cos \theta) d\theta}{\sqrt{a^2 - a^2 \sin^2 \theta}}$$

$$= -2 \frac{a^3}{a} \int_{\pi/2}^0 \sin \theta (1 - \sin \theta) d\theta$$

$$= 2a^2 \int_0^{\pi/2} (\sin \theta - \sin^2 \theta) d\theta$$

$$= 2a^2 \left[1 - \frac{1}{2} \cdot \frac{1}{2} \cdot \pi \right]$$

$$= 2a^2 \left[1 - \frac{\pi}{4} \right]$$

- 22.(C)** When a curve joining $P_1(x_1, y_1)$ and $P_2(x_2, y_2)$ is revolved about x-axis, the area of the surface of revolution is given by

$$S[y(x)] = 2\pi \int_{x_1}^{x_2} y (1 + y'^2)^{1/2} dx$$

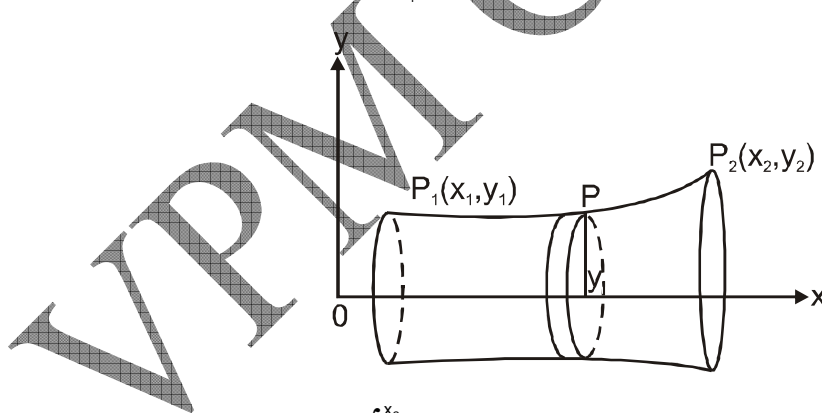

Comparing this with $\int_{x_1}^{x_2} F(x, y, y') dx$ and omitting the irrelevant factor 2π , we have

$$F(x, y, y') = y (1 + y'^2)^{1/2}$$

Since $F(x,y,y')$ is a function of y and y' only, a first integral of Euler's equation is $F - y'(\partial F/\partial y') = \text{constant} = C$

$$\text{or } y(1 + y'^2)^{1/2} - y'x(y/2) \times (1 + y'^2)^{-1/2} \times 2y' = C$$

$$\text{or } y(1 + y'^2) - yy'^2 = C(1 + y'^2)^{1/2} \quad \text{or } y = C(1 + y'^2)^{1/2}$$

$$\text{or } y'^2 = \frac{y^2 - C^2}{C^2} \quad \text{or } \frac{dy}{dx} = \frac{(y^2 - C^2)^{1/2}}{C}$$

Separating variables,
$$\frac{dy}{(y^2 - C^2)^{1/2}} = \frac{dx}{C}$$

Integrating, $\cosh^{-1}(y/C) = x/C + b/C$ or $y = C \cosh\{(x+b)/C\}$ (1)

Where b and C are two arbitrary constants. (1) gives a two parameter family of catenaries.

23.(B) Let
$$I = \iint_D e^{x/y} dA \quad D = \{(x,y) | 1 \leq y \leq 2, y \leq x \leq y^3\}$$

$$\iint_D e^{x/y} dx dy = \int_1^2 \int_y^{y^3} e^{x/y} dx dy$$

$$= \int_1^2 e^{x/y} \Big|_y^{y^3} dy$$

$$= \int_1^2 ye^{y^2} - ye^1 dy$$

$$= \left(\frac{1}{2} e^{y^2} - \frac{1}{2} y^2 e^1 \right) \Big|_1^2$$

$$= \frac{1}{2} e^4 - 2e^1$$

$$= \frac{e^4 - 4e}{2}$$

24.(D) Since
$$\frac{1}{R} = \lim_{n \rightarrow \infty} |a_n|^{1/n}$$

$$= \lim_{n \rightarrow \infty} \left| \frac{(x-6)^n}{n^n} \right|^{1/n}$$

$$= \lim_{n \rightarrow \infty} \left| \frac{x-6}{n} \right|$$

$$= |x-6| \lim_{n \rightarrow \infty} \frac{1}{n}$$

$$\frac{1}{\infty} = 0$$

Radius of convergence is $R = \infty$

and since radius of convergence is regardless of the value of x so converges for entire real plane

25.(D) Let $f(x) = \cos\left(\frac{1}{2}\pi x\right)$, $g(x) = \log x$, $a = x$, $b = 1$.

Putting these values in Cauchy's mean value theorem,

$$\frac{f(b) - f(a)}{g(b) - g(a)} = \frac{f'(c)}{g'(c)}, \quad a < c < b, \text{ we get}$$

$$\frac{\cos\frac{1}{2}\pi - \cos\frac{1}{2}\pi x}{\log 1 - \log x} = \frac{-\frac{1}{2}\pi \sin\left(\frac{1}{2}\pi c\right)}{1/c}, \quad x < c < 1.$$

Taking limits as $x \rightarrow 1$ which implies that $c \rightarrow 1$, we get

$$\lim_{x \rightarrow 1} \left\{ \frac{0 - \cos\left(\frac{1}{2}\pi x\right)}{\log(1/x)} \right\} = \lim_{c \rightarrow 1} \left\{ \frac{-\frac{1}{2}\pi \sin\left(\frac{1}{2}\pi c\right)}{1/c} \right\}$$

Or $\lim_{x \rightarrow 1} \left\{ \frac{-\cos\left(\frac{1}{2}\pi x\right)}{\log(1/x)} \right\} = -\frac{1}{2}\pi$ as $\left(\frac{1}{2}\pi c\right) \rightarrow 1$ as $c \rightarrow 1$

or $\lim_{x \rightarrow 1} \left\{ \frac{\cos\left(\frac{1}{2}\pi x\right)}{\log(1/x)} \right\} = \frac{\pi}{2}$

26.(B) Since $f(x, y, z) = \sin y z + \ln(x^2)$

$$\begin{aligned} \text{gradient of } f \text{ is } \nabla f &= \left(i \frac{\partial}{\partial x} + j \frac{\partial}{\partial y} + k \frac{\partial}{\partial z} \right) (\sin yz + \ln x^2) \\ &= \frac{2}{x} i + z \cos(yz) j + y \cos(yz) k \end{aligned}$$

$$[\nabla f]_{(1,1,\pi)} = 2\hat{i} + \pi\hat{j} - \hat{k}$$

unit vector in the direction $\hat{i} + \hat{j} - \hat{k}$ is

$$\left(\frac{\hat{i} + \hat{j} - \hat{k}}{\sqrt{3}} \right)$$

so directional derivative

$$\begin{aligned} D(1,1,\pi) &= (2 - \pi\hat{j} - \hat{k}) \cdot \frac{(\hat{i} + \hat{j} - \hat{k})}{\sqrt{3}} \\ &= \frac{3 - \pi}{\sqrt{3}} \end{aligned}$$

27.(B) Suppose $F_1 dx + F_2 dy + F_3 dz = d\phi = \frac{\partial \phi}{\partial x} dx + \frac{\partial \phi}{\partial y} dy + \frac{\partial \phi}{\partial z} dz$ an exact differential Then since x,y

and z are independent variables

$$F_1 = \frac{\partial \phi}{\partial x}, \quad F_2 = \frac{\partial \phi}{\partial y}, \quad F_3 = \frac{\partial \phi}{\partial z}$$

$$\text{so } \vec{F} = F_1 \hat{i} + F_2 \hat{j} + F_3 \hat{k} = \frac{\partial \phi}{\partial x} \hat{i} + \frac{\partial \phi}{\partial y} \hat{j} + \frac{\partial \phi}{\partial z} \hat{k} = \nabla \phi$$

Thus

$$\vec{\nabla} \times \vec{F} = \nabla \times \nabla \phi = 0$$

now $\vec{F} = (y^2 z^3 \cos x - 4x^4 z) \hat{i} + (2z^3 y \sin x) \hat{j} + (3y^2 z^2 \sin x - x^4) \hat{k}$ and $\vec{\nabla} \times \vec{F}$ is computed to be zero

$$\text{so } (y^2 z^3 \cos x - 4x^4 z) dx + 2z^3 y \sin x dy + (3y^2 z^2 \sin x - x^4) dz = d\phi$$

$$\Rightarrow \phi = y^2 z^3 \sin x - x^4 z + \text{constant}$$

28.(A) $\frac{dy}{dx} = \frac{y \sin y/x}{x \sin y/x}$

or $V + x \frac{dV}{dx} = \frac{V \sin V - 1}{\sin V}$

$\left(\because y = Vx, \frac{dy}{dx} = V + x \frac{dV}{dx} \right)$

or $x \frac{dV}{dx} = \frac{V \sin V - 1}{\sin V} - V$
 $= \frac{-1}{\sin V}$

or $\sin V dV + \frac{dx}{x} = 0$

Integrating, we obtain

$-\cos V + \log x = c$

Hence $\log x = \cos y/x + c$ is the required solution.

29.(C) $\because f'(x) > 0$

$\therefore f(x)$ is increasing function and also given $f''(x) > 0$ then graph of $f(x)$ is concave up.

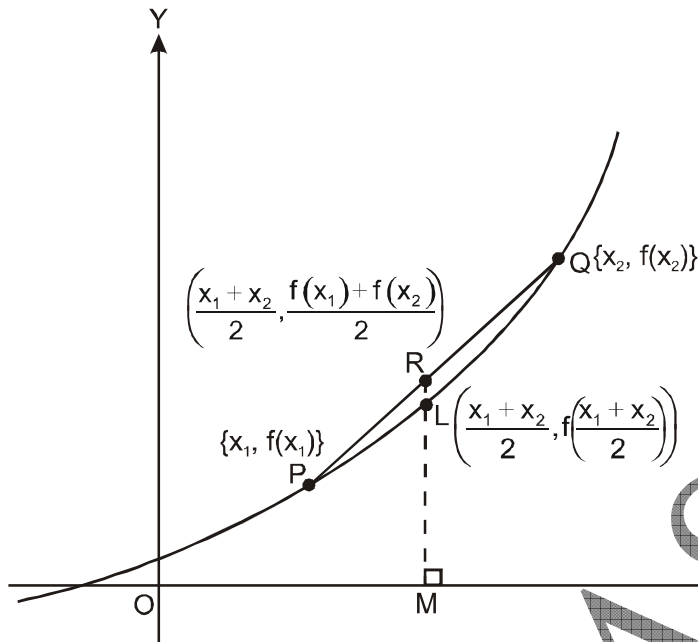

Let $P(x_1, f(x_1))$ and $Q(x_2, f(x_2))$ be any two points on $y = f(x)$

Joining P and Q, if R the mid-point of PQ then co-ordinates of R is

$$\left(\frac{x_1 + x_2}{2}, \frac{f(x_1) + f(x_2)}{2} \right)$$

Draw perpendicular RM on x-axis. If RM cuts the graph of $y = f(x)$ at L then co-ordinates of

L are $\left(\frac{x_1 + x_2}{2}, f\left(\frac{x_1 + x_2}{2}\right) \right)$

It is clear from the graph that $ML < RM$

i.e., (y-co-ordinates of L) < (y-co-ordinates of R)

$$\Rightarrow f\left(\frac{x_1 + x_2}{2}\right) < \frac{f(x_1) + f(x_2)}{2}$$

30.(C) We first observe that the equation is exact in every rectangular domain D, since

$$\frac{\partial M(x,y)}{\partial y} = -2x \sin y + 3x^2 = \frac{\partial N(x,y)}{\partial x}$$

for all real (x, y) .

Now, We must find F such that

$$\frac{\partial F(x,y)}{\partial x} = M(x,y) = 2x \cos y + 3x^2y$$

and

$$\frac{\partial F(x,y)}{\partial y} = N(x,y) = x^3 - x^2 \sin y - y.$$

Then

$$\begin{aligned} F(x,y) &= \int M(x,y) \partial x + \phi(y) \\ &= \int (2x \cos y + 3x^2y) \partial x + \phi(y) \\ &= x^2 \cos y + x^3y + \phi(y), \end{aligned}$$

$$\frac{\partial F(x,y)}{\partial y} = -x^2 \sin y + x^3 + \frac{d\phi(y)}{dy}$$

But also

$$\frac{\partial F(x,y)}{\partial y} = N(x,y) = x^3 - x^2 \sin y - y$$

and so

$$\frac{d\phi(y)}{dy} = -y$$

and hence

$$\phi(y) = -\frac{y^2}{2} + C_0.$$

Thus

$$F(x,y) = x^2 \cos y + x^3y - \frac{y^2}{2} + C_0.$$

Hence a one-parameter family of solutions is $F(x,y) = c_1$, which may be expressed as

$$x^2 \cos y + x^3y - \frac{y^2}{2} = c.$$

Applying the initial condition $y = 2$ when $x = 0$, we find $c = -2$. Thus the solution of the given initial-value problem is

$$X^2 \cos y + x^3 y - \frac{y^2}{2} = -2.$$

31. (B) If $S_1 = \sum \frac{(-1)^{n-1}}{n} x^n$

Take $v_n(x) = x^n$ and $u_n(x) = \frac{(-1)^{n-1}}{n}$

The sequence $\{v_n(x)\}$ is clearly uniformly bounded and monotonic non-increasing on $[0, 1]$

Also the series $\sum \frac{(-1)^{n-1}}{n}$ is convergent.

Hence by Abel's test the given series is uniformly convergent on $[0, 1]$

(B) $M_n = \text{Sup}\{|f_n(x) - f(x)| : x \in \mathbb{R}\}$

here $f(x) = \lim_{n \rightarrow \infty} \frac{n^2 x}{1+n^4 x^2} = 0 \forall x \in [0,1]$

Therefore $|f_n(x) - f(x)| = \frac{n^2 |x|}{1+n^4 x^2}$

$M_n = \text{Sup} \left\{ \frac{n^2 |x|}{1+n^4 x^2} : x \in \mathbb{R} \right\}$

$\geq \frac{n^2 \cdot \frac{1}{n^2}}{1+n^4 \cdot \frac{1}{n^4}} = \frac{1}{2}$ (Taking $x = \frac{1}{n^2} \in \mathbb{R}$)

Hence M_n cannot tend to zero as $n \rightarrow \infty$ and consequently the sequence is non uniformly convergent by M_n test

(c) Here $f(x) = \lim_{n \rightarrow \infty} \frac{x}{1+nx^2} = 0 \forall x \in (0,1)$

$$M_n = \text{Sup}\{|f_n(x) - f(x)|\} = \text{Sup}\left\{\frac{|x|}{1+nx^2}, x \in \mathbb{R}\right\}$$

$$\text{for Sup } \frac{d}{dx}\left(\frac{x}{1+nx^2}\right) = 0$$

$$\Rightarrow x = \frac{1}{\sqrt{x}}$$

$$\text{so } M_n = \text{Sup}\left\{\frac{x}{1+nx^2} : x \in \mathbb{R}\right\}$$

$$= \frac{1}{2\sqrt{n}} M_n \rightarrow 0 \text{ as } n \rightarrow \infty$$

Hence sequence is uniformly convergent.

$$(D) f(x) = \lim_{n \rightarrow \infty} f_n(x)$$

$$= \lim_{n \rightarrow \infty} x^{n-1}(1-x) = 0 \quad \forall x \in [0,1]$$

$$y = |f_n(x) - f(x)| = x^{n-1}(1-x)$$

$$\text{for } y \text{ is maximum } \frac{dy}{dx} = 0 \text{ gives } x = \frac{n-1}{n}$$

$$\frac{d^2y}{dx^2} = -ve \quad \text{at } x = \frac{n-1}{n}$$

$$\text{so } M_n = \max y = \left(1 - \frac{1}{n}\right)^{n-1} \left(1 - \frac{n-1}{n}\right) \rightarrow \frac{1}{e} \times 0 = 0 \text{ as } n \rightarrow \infty$$

Hence the sequence is uniformly convergent on $[0, 1]$.

32.(B) Cayley Hamilton Theorem This states that "every square matrix satisfies its characteristic equation"

$$\text{we have } A = \begin{bmatrix} 3 & -2 \\ 4 & -2 \end{bmatrix}$$

$$|A - \lambda I| = \begin{vmatrix} 3-\lambda & -2 \\ 4 & -2-\lambda \end{vmatrix} = 0$$

Here ,

$$\Rightarrow (3 - \lambda)(-2 - \lambda) - 4(-2) = 0$$

$$-(3 - \lambda)(\lambda + 2) + 8 = 0$$

$$\Rightarrow \lambda^2 - \lambda - 6 + 8 = 0$$

$$\Rightarrow \lambda^2 - \lambda + 2 = 0$$

Hence, by Cayley Hamilton theorem

$$A^2 - A + 2I = 0$$

Comparing this with

$$A^2 - kA + 2I = 0$$

we get , $k = 1$

33.(B) Given $f(x)$ is differentiable at $x = 0$. Hence , $f(x)$ will be continuous at $x = 0$.

$$\therefore \lim_{x \rightarrow 0^-} (e^x + ax) = \lim_{x \rightarrow 0^+} b(x-1)^2$$

$$\Rightarrow e^0 + a \times 0 = b(0-1)^2 \Rightarrow b = 1 \quad \dots(1)$$

But $f(x)$ is differentiable at $x = 0$, then

$$Lf'(x) = Rf'(x) \Rightarrow \frac{d}{dx}(e^x + ax) = \frac{d}{dx}b(x-1)^2$$

$$\Rightarrow e^x + a = 2b(x-1)$$

$$\text{At } x = 0, e^0 + a = -2b \Rightarrow a + 1 = -2b$$

$$\Rightarrow a + 1 = -2 \Rightarrow \boxed{a = -3}$$

Hence $f(x)$ is differentiable at $x = 0$, then $(a, b) = (-3, 1)$

34.(C) Here,

$$\frac{d^2y}{dx^2} - 2a \frac{dy}{dx} + a^2y = f(x)$$

$\therefore e^{ax}u(x)$ is a particular integral of it. So, it will satisfy the Eq. (i) and $y = e^{ax}u(x)$.

$$\therefore \frac{d}{dx}\{e^{ax}u(x)\} = e^{ax}u'(x) + ae^{ax}u(x)$$

$$\begin{aligned} \text{and } \frac{d^2}{dx^2} \{e^{ax}u(x)\} &= e^{ax} \cdot u''(x) + u'(x) \cdot ae^{ax} + a\{e^{ax} \cdot u'(x) + u(x) \cdot ae^{ax}\} \\ &= e^{ax}u''(x) + ae^{ax}u'(x) + ae^{ax}u'(x) + a^2e^{ax}u(x) \\ &= e^{ax}u''(x) + 2ae^{ax}u'(x) + a^2e^{ax}u(x) \end{aligned}$$

Substituting these values in above equation we get

$$\begin{aligned} e^{ax}u''(x) + 2ae^{ax}u'(x) + a^2e^{ax}u(x) \\ 2a\{e^{ax}u'(x) + ae^{ax}u(x)\} + a^2e^{ax}u(x) &= f(x) \\ = e^{ax}u''(x) + 2ae^{ax} \cdot u'(x) + a^2e^{ax}u(x) - 2ae^{ax}u'(x) \\ -2a^2e^{ax}u(x) + a^2e^{ax}u(x) &= f(x) \\ \text{or } e^{ax} \cdot u''(x) &= f(x) \\ \text{or } u''(x) &= \frac{f(x)}{e^{ax}} = f(x) \cdot e^{-ax} \\ \text{or } \frac{d^2u}{dx^2} &= f(x) \cdot e^{-ax} \end{aligned}$$

35.(A) Here, it is given that a family of circle having the radius r and centre on the x -axis.

\therefore Equation of family of circle whose radius is r and centre $(a, 0)$ lie on x -axis is

$$(x - a)^2 + y^2 = r^2 \quad \dots (i)$$

Now, differentiating it w.r.t. x , we get

$$\begin{aligned} 2(x - a) + 2y \frac{dy}{dx} &= 0 \\ \text{or } 2(x - a) &= -2y \frac{dy}{dx} \\ \text{or } (x - a) &= -y \frac{dy}{dx} \end{aligned}$$

Now substituting this value in Eq. (i), we get

$$\left(-y \frac{dy}{dx}\right)^2 + y^2 = r^2$$

$$y^2 \left(\frac{dy}{dx} \right)^2 + y^2 = r^2$$

$$y^2 \left[1 + \left(\frac{dy}{dx} \right)^2 \right] = r^2$$

36.(D) for the power series we know that the following results

- i) Power series diverges for every value of x other than 0
- ii) The power series converges for every value of x .
- iii) If there exists a positive number R such that the power series converges for every x than $|x| < R$, where R is the radius of convergence of the power series. and diverges for every x s.t. $|x| \geq R$.

Here given that power series $\sum_{n=0}^{\infty} a_n x^n$

converges to 5 i.e. $|5| < R \Rightarrow R > 5$

37.(A) From the given integral , inequalities that define this region are,

$$0 \leq x \leq 3$$

$$x^2 \leq y \leq 9$$

These inequalities tell us that we want the region with $y = x^2$ on the lower boundary and $y = 9$ on the upper boundary that lies between $x = 0$ and $x = 3$.

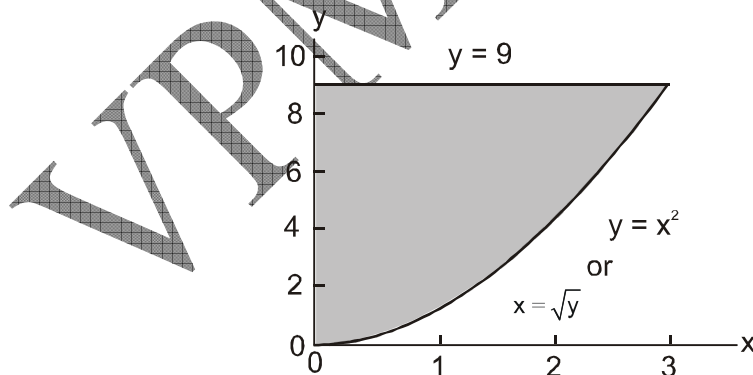

Since we want to integrate with respect to x first determine limits of x(probably in term of y) and then get the limits on the y's.

$$0 \leq x \leq \sqrt{y}$$

$$0 \leq y \leq 9$$

Any horizontal line drawn in this region will start at $x = 0$ and end at $x = \sqrt{y}$ and so these are the limits on the x's and the range of y's for the regions is 0 to 9.

The integral, with the order reversed, is now,

$$\begin{aligned} \int_0^3 \int_{x^2}^9 x^3 e^{y^3} dy dx &= \int_0^9 \int_0^{\sqrt{y}} x^3 e^{y^3} dx dy \\ &= \int_0^9 \left. \frac{1}{4} x^4 e^{y^3} \right|_0^{\sqrt{y}} dy \\ &= \int_0^9 \frac{1}{4} y^2 e^{y^3} dy \\ &= \frac{1}{12} e^{y^3} \Big|_0^9 \\ &= \frac{1}{12} (e^{729} - 1) \end{aligned}$$

38. (B) Given function is

$$f(x) = (1 - x)^{5/2}$$

$$\therefore f(0) = 1, f'(0) = -\frac{5}{2}$$

$$f''(\theta x) = \frac{15}{4} (1 - \theta x)^{1/2}$$

Substituting these values in

$$f(x) = f(0) + xf'(0) + \frac{x^2}{2} f''(\theta x)$$

$$(1 - x)^{5/2} = 1 + x \cdot \left(-\frac{5}{2}\right) + \frac{x^2}{2} \cdot \frac{15}{4} (1 - \theta x)^{1/2}$$

Taking as $x \rightarrow 1$, we get

$$0 = 1 - \frac{5}{2} + \frac{1}{2} \cdot \frac{15}{4} (1 - \theta)^{1/2}.$$

$$\text{or, } (1 - \theta)^{1/2} = \frac{4}{5}$$

$$\text{or, } 1 - \theta = \frac{16}{25}$$

$$\therefore \theta = \frac{9}{25}$$

\therefore The correct answer is (B)

39.(A) Let $s_n = \sum_{k=1}^n u_k$, $t_n = \sum_{k=1}^n M_k$. Then, for $m > n \geq N_1$,

$$\begin{aligned} |s_m(x) - s_n(x)| &= \left| \sum_{k=n+1}^m u_k(x) \right| \leq \sum_{k=n+1}^m |u_k(x)| \\ &\leq \sum_{k=n+1}^m M_k = t_m - t_n \quad (x \in E). \end{aligned} \quad \dots(1)$$

since $\sum_{k=1}^{\infty} M_k < \infty$, $\{t_n\}_{n=1}^{\infty}$ is a converging sequence and hence a cauchy sequence. Thus

given $\epsilon > 0$, there exists

$N \geq N_1$ such that

$$|t_m - t_n| < \epsilon \quad (m, n \geq N).$$

But then (1) implies

$$|s_m(x) - s_n(x)| < \epsilon \quad (m, n \geq N; x \in E).$$

$\{s_n\}_{n=1}^{\infty}$ converges uniformly on E . This means that $\sum_{k=1}^{\infty} u_k$ converges uniformly on E ,

40.(C) parametric equations of the sphere are

$$x = a + \rho \sin \theta \cos \phi, y = b + \rho \sin \theta \sin \phi$$

$$z = c + \rho \cos \theta$$

and to cover the whole sphere, r varies from 0 to p , θ varies from 0 to π and ϕ from 0 to 2π .

$$\begin{aligned} \therefore \int_S (lx^2 + my^2 + nz^2) ds &= \int_S (x^2i + my^2j + nz^2k) \cdot N ds \\ &= \int_V \operatorname{div}(x^2i + y^2j + z^2k) dv \\ &= 2 \int_V (x + y + z) dv \\ &= 2 \int_0^{2\pi} \int_0^\pi \int_0^p [(a + b + c) + p(\sin\theta\cos\phi + \sin\theta\sin\phi + \cos\theta)] \times r^2 \sin\theta dr \cdot d\theta d\phi \\ &= 2(a + b + c) \frac{p^3}{3} \Big|_{-\cos\theta}^\pi \cdot 2\pi \\ &= \frac{8\pi}{3} (a + b + c) p^3 \end{aligned}$$

41. Given $y = e^{x^2}$ is an integral belonging to the C.F. of the given equation.

$$\therefore \text{Let } y = ze^{x^2} \quad \dots (i)$$

be the complete solution of the given equation, where z is a function of x to be determined.

$$\text{From (i), } y_1 = z_1 e^{x^2} + 2xe^{x^2} z_1,$$

$$y_2 = z_2 e^{x^2} + 4xe^{x^2} z_2 + 2z_2(1 + 2x^2)e^{x^2}$$

Substituting these values of y_2 , y_1 and y in the given equation, we get

$$x[z_2 + 4xz_1 + 2(1 + 2x^2)z] - [z_1 + 2xz] - 4x^3z = -4x^5 e^{-x^2}$$

$$\text{or } xz_2 + (4x^2 - 1)z_1 + [2x(1 + 2x^2) - 2x - 4x^3]z = -4x^5 e^{-x^2}$$

$$\text{or } \frac{dz_1}{dx} + \left(4x - \frac{1}{x}\right)z_1 = -4x^4 e^{-x^2}$$

Which is a linear equation of first order in z_1 .

$$\text{Its integrating factor} = e^{\int [4x - (1/x)] dx} = e^{2x^2 - \log x}$$

$$= e^{2x^2} \times e^{-\log x} = (1/x)e^{2x^2}$$

$$\therefore \text{Its solution is } z_1 \cdot (1/x) e^{2x^2} = c_1 - 4 \int x^4 e^{-x^2} \cdot (1/x) e^{2x^2} dx$$

$$\begin{aligned}
 \text{or } z_1(1/x)e^{2x^2} &= c_1 - 4 \int x^3 e^{x^2} dx \\
 &= c_1 - 2 \int te^t dt, \text{ putting } x^2 = t \\
 &= c_1 - 2 \left[te^t - \int 1 \cdot e^t dt \right] = c_1 - 2te^t + 2e^t \\
 &= c_1 - 2x^2 e^{x^2} + 2e^{x^2}
 \end{aligned}$$

$$\text{or } z_1 = x \left[c_1 e^{-2x^2} - 2x^2 e^{-x^2} + 2e^{-x^2} \right]$$

$$\begin{aligned}
 \text{or } dz &= \left(c_1 x e^{-2x^2} - 2x^3 e^{-x^2} + 2x e^{-x^2} \right) dx \\
 &= \left(-\frac{1}{2} c_1 e^{2t} - te^t - e^t \right) dt, \text{ putting } -x^2 = t
 \end{aligned}$$

$$\begin{aligned}
 \text{Integrating, } z &= c_2 - \frac{1}{4} c_1 e^{2t} - \int te^t dt - e^t \\
 &= c_2 - \frac{1}{4} c_1 e^{2t} - \left[te^t - \int 1 \cdot e^t dt \right] - e^t \\
 &= c_2 - \frac{1}{4} c_1 e^{2t} - te^t + e^t - e^t
 \end{aligned}$$

$$\text{or } z = c_2 - \frac{1}{4} c_1 e^{-2x^2} + x^2 e^{-x^2}$$

Substituting this value of z in (i), the required solution is

$$y = c_2 e^{x^2} - \frac{1}{4} c_1 e^{-x^2} + x^2,$$

where c 's are arbitrary constants.

42. (a) (i) For any $x = a$,

$$\text{L.H.L.} = \lim_{x \rightarrow a^-} f(x) = \lim_{h \rightarrow 0} f(a-h) \quad \text{and} \quad \text{R.H.L.} = \lim_{x \rightarrow a^+} f(x) = \lim_{h \rightarrow 0} f(a+h)$$

Hence $f(x)$ oscillates between 0 and 1 as x is rational or irrational

\therefore L.H.L. and R.H.L. do not exist.

$\Rightarrow f(x)$ is discontinuous at a point $x = a$ for all values of a .

(ii) For any $x = a$,

$$\lim_{x \rightarrow a} f(x) = \lim_{x \rightarrow a} x = a \quad (\text{when } x \rightarrow a \text{ through rational values})$$

$$\text{and } \lim_{x \rightarrow a} f(x) = \lim_{x \rightarrow a} (1-x) = 1-a$$

(when $x \rightarrow a$ through irrational values)

Now $\lim_{x \rightarrow a}$ will exist only when $a = 1 - a$

$$\Rightarrow a = \frac{1}{2}$$

Thus if $x \neq \frac{1}{2}$, then $\lim_{x \rightarrow a} f(x)$ will not exist.

Hence $f(x)$ is discontinuous when $a \neq \frac{1}{2}$.

Hence $f(x)$ is continuous at $x = \frac{1}{2}$.

(b) Let $A = \begin{vmatrix} x+2 & x+3 & x+a \\ x+4 & x+5 & x+b \\ x+6 & x+7 & x+c \end{vmatrix}$

Applying $C_2 \rightarrow C_2 - C_1$, we get,

$$\Rightarrow A = \begin{vmatrix} x+2 & 1 & x+a \\ x+4 & 1 & x+b \\ x+6 & 1 & x+c \end{vmatrix}$$

Applying $R_2 \rightarrow R_2 - R_1$ and $R_3 \rightarrow R_3 - R_1$,

$$\begin{aligned} \Rightarrow A &= \begin{vmatrix} x+2 & 1 & x+a \\ 2 & 0 & b-a \\ 4 & 0 & c-a \end{vmatrix} = -1(2c - 2a - 4b + 4a) \\ &= 2(2b - c - a) \end{aligned}$$

given a, b , are in A.P. $\Rightarrow A = 0$.

Trick: Let a, b, c are in A.P. Put $a = 4, b = 5, c = 6$

$$\begin{vmatrix} x+2 & x+3 & x+4 \\ x+4 & x+5 & x+6 \\ x+6 & x+7 & x+8 \end{vmatrix}$$

$$\begin{bmatrix} x+2 & 1 & 1 \\ x+4 & 1 & 1 \\ x+6 & 1 & 1 \end{bmatrix} = 0 [C_1 \rightarrow C_2 - C_1, C_3 \rightarrow C_3 - C_2]$$

43. The given system of equations is equivalent to a single matrix equation

$$\begin{bmatrix} 1 & 1 & 1 \\ 1 & 2 & 4 \\ 1 & 4 & 10 \end{bmatrix} \begin{bmatrix} x \\ y \\ z \end{bmatrix} = \begin{bmatrix} 1 \\ \mu \\ \mu^2 \end{bmatrix} \quad \dots (1)$$

Applying row operations $R_{21}(-1)$ and $R_{31}(-1)$ to the coefficient matrix and also to the matrix on R. H. S. of (1), we get

$$\begin{bmatrix} 1 & 1 & 1 \\ 0 & 1 & 3 \\ 0 & 3 & 9 \end{bmatrix} \begin{bmatrix} x \\ y \\ z \end{bmatrix} = \begin{bmatrix} 1 \\ \mu - 1 \\ \mu^2 - 1 \end{bmatrix}$$

Again, applying the row operation $R_{32}(-3)$, we get

$$\begin{bmatrix} 1 & 1 & 1 \\ 0 & 1 & 3 \\ 0 & 0 & 0 \end{bmatrix} \begin{bmatrix} x \\ y \\ z \end{bmatrix} = \begin{bmatrix} 1 \\ \mu - 1 \\ \mu^2 - 3\mu + 2 \end{bmatrix} \quad \dots (2)$$

This is equivalent to the following system of equations.

$$\left. \begin{array}{l} x + y + z = 1 \quad \dots (a) \\ y + 3z = \mu - 1 \quad \dots (b) \\ 0 = \mu^2 - 3\mu + 2 \quad \dots (c) \end{array} \right\} \quad \dots (3)$$

The last equation of (3) i.e. (3c) represents the condition for the given system of equations to be consistent. From (3c) we have

$$\mu^2 - 3\mu + 2 = 0$$

or $(\mu - 1)(\mu - 2) = 0$

i.e. either $\mu = 1$ or $\mu = 2$

Case (i) When $\mu = 1$

Then (3a) and (3b) take the form

$$x + y + z = 1$$

$$y + 3z = 0$$

which yields

$$y = -3z$$

$$x = 1 - (-3z) - z = 1 + 2z$$

If $z = a$, where a is any arbitrary number, then

$$\left. \begin{array}{l} x = 1 + 2a \\ y = -3a \\ z = a \end{array} \right\} \dots (4)$$

This is the required solution in case $\mu = 1$.

Case (ii) When $\mu = 2$.

Then (3a) and (3b) take the form

$$x + y + z = 1$$

$$y + 3z = 1$$

These equations yield

$$y = 1 - 3z$$

$$x = 1 - (1 - 3z) - z = 2z$$

If $z = b$, where b is any arbitrary number, then

$$\left. \begin{array}{l} x = 2b \\ y = 1 - 3b \\ z = b \end{array} \right\} \dots (5)$$

This is the required solution for $\mu = 2$.

As a and b are arbitrary numbers, the solutions (4) and (5) represent an infinite number of solutions.

44. (a) The normal to the ellipsoid is along the direction of $\text{grad}(ax^2 + by^2 + cz^2) = 2(axi + byj + czk)$.

$$\therefore \mathbf{n} = (axi + byj + czk)/(a^2x^2 + b^2y^2 + c^2z^2)^{1/2}. \quad (1)$$

Now comparing the given integral with $\mathbf{F} \cdot \mathbf{n}$, it can be easily found that $\mathbf{F} = xi + yj + zk$ on the ellipsoid

$$ax^2 + by^2 + cz^2 = 1.$$

∴ the surface integral

$$\iint_S (a^2x^2 + b^2y^2 + c^2z^2)^{-\frac{1}{2}} dS$$

$$= \iint_S (\mathbf{x}\mathbf{i} + \mathbf{y}\mathbf{j} + \mathbf{z}\mathbf{k}) \cdot (\mathbf{a}\mathbf{x}\mathbf{i} + \mathbf{b}\mathbf{y}\mathbf{j} + \mathbf{c}\mathbf{z}\mathbf{k}) / (a^2x^2 + b^2y^2 + c^2z^2)^{\frac{1}{2}} dS = \iint_S \mathbf{F} \cdot \mathbf{n} dS$$

$$= \int_V \text{div } \mathbf{F} dV, \text{ (By divergence theorem).}$$

$$= 3 \int_V dV = 3V = 3 \times \text{volume of ellipsoid.}$$

To find the volume V, the eqn. of the ellipsoid $ax^2 + by^2 + cz^2 = 1$ can be written as

$$\frac{x^2}{(1/\sqrt{a})^2} + \frac{y^2}{(1/\sqrt{b})^2} + \frac{z^2}{(1/\sqrt{c})^2} = 1$$

$$\therefore V = \frac{4\pi}{3} \left(\frac{1}{\sqrt{a}} \cdot \frac{1}{\sqrt{b}} \cdot \frac{1}{\sqrt{c}} \right) = \frac{4\pi}{3\sqrt{abc}}$$

$$\therefore \iint_S (a^2x^2 + b^2y^2 + c^2z^2)^{-\frac{1}{2}} dS = \frac{4\pi}{\sqrt{abc}}$$

(b) The parametric equation of the plane is $x = u, y = v, z = 1 - u - v$.

Then $\mathbf{r} = u\mathbf{i} + v\mathbf{j} + (1 - u - v)\mathbf{k}$ and $d\mathbf{S} = \mathbf{n} dS = \mathbf{r}_u \times \mathbf{r}_v du dv$

$= (1, 0, -1) \times (0, 1, -1) dx dy$ [$\because x = u$ and $y = v$ as taken]

$$\therefore ds = (1, 1, 1) dx dy$$

Also $\text{curl } \mathbf{f} = (2, 2, -1)$

$$\therefore \iint_{ABC} \mathbf{n} \cdot \text{curl } \mathbf{f} dS$$

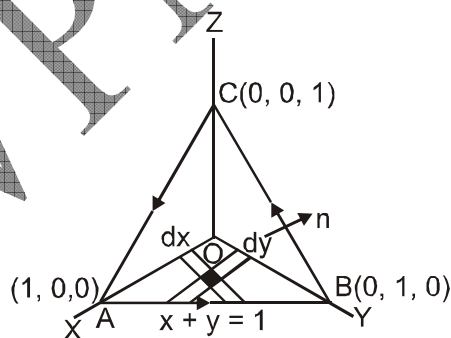

$$= \iint_{AOB} 3dx dy = 3 \int_0^1 \int_0^1 dx dy = \frac{3}{2}, \quad (1)$$

The above result can also be obtained easily as the area of $\Delta AOB = \frac{1}{2}$

The positive sense of C is ABC corresponding to the direction of n and

$$\begin{aligned} \int_C \mathbf{f} \cdot d\mathbf{r} &= \int_{ABC} (2y+z)dx + (x-z)dy + (y-x)dz \\ &= \int_{AB} + \int_{BC} + \int_{CA} \end{aligned}$$

Now equation of AB is $x + y = 1, z = 0$ and so,

$$\begin{aligned} \int_{AB} &= \int_{AB} (2ydx + xdy) \\ &= \int_1^0 [(2-2x)dx - x dx] = -\frac{1}{2}; \text{ Similarly, } \int_{CA} = 1. \end{aligned}$$

$$\therefore \int_C \mathbf{f} \cdot d\mathbf{r} = -\frac{1}{2} + 1 + 1 = \frac{3}{2}. \quad (2)$$

$$\therefore \int_C \mathbf{f} \cdot d\mathbf{r} = \iint_S \mathbf{n} \cdot \text{curl} \mathbf{f} dS = \frac{3}{2}.$$

Thus the theorem is verified from (1) and (2).

45. (a) We have

$$u_n^2 - u_{n-1}^2 = (k + u_{n-1}) - (k + u_{n-2}) = u_{n-1} - u_{n-2}$$

so that $u_n >$ or $<$ u_{n-1} according as $u_{n-1} >$ or $<$ u_{n-2} and thus $\{u_n\}$ is a monotonic sequence; it is increasing or decreasing sequence according as $u_2 >$ or $<$ u_1 . Now

$$x^2 - x - k \equiv (x - \alpha)(x + \beta) \quad \dots(1)$$

so that $u_1^2 - u_1 - k = (u_1 - \alpha)(u_1 + \beta).$

Let $u_1 > \alpha$; then $u_1^2 - u_1 - k > 0$, so that $u_2 = \sqrt{u_1 + k} < u_1$.

Therefore $\{u_n\}$ is a decreasing sequence.

Now $u_n^2 = u_{n-1} + k > u_n + k, \quad [\because u_n < u_{n-1}]$

i.e. $u_n^2 - u_n - k > 0.$

$$\therefore \text{ from (1), } u_n^2 - u_n - k = (u_n - \alpha)(u_n + \beta) > 0.$$

$$\text{Hence } u_n > \alpha. \quad \dots(2)$$

Since u_1 is +ve. $u_2, u_3, \dots, u_n, \dots$, are all +ve by virtue of the relation $u_n = (k + u_{n-1})$.

Hence $\{u_n\}$ is bounded, being a monotonic decreasing sequence of positive terms. It follows that $\{u_n\}$ is convergent.

Hence $u_n \rightarrow a$ is finite limit, say l . Clearly from (2). $l \geq \alpha$.

$$\text{Now } (u_n - \alpha)(u_n + \beta) = u_n^2 - u_n - k = (u_{n-1} + k) - u_n - k.$$

Proceeding to the limit, we get

$$(l - \alpha)(l + \beta) = l - l = 0,$$

or $l = \alpha$ for $l \neq -\beta$, which is $< \alpha$.

Hence l is equal to the positive root α of the equation

$$x^2 = x + k.$$

(b) Given that $f(0) = 0$ and $f'(0) = 1$

$$\text{then } \lim_{x \rightarrow 0} \frac{1}{x} \{f(x) + f(x/2) + \dots + f(x/k)\}$$

$$= \lim_{x \rightarrow 0} \left\{ \frac{f(x) - f(0)}{x} + \frac{1}{2} \frac{f(x/2) - f(0)}{x/2} + \dots + \frac{1}{k} \frac{f(x/k) - f(0)}{x/k} \right\}$$

$$= \lim_{x \rightarrow 0} \left\{ f'(0) + \frac{1}{2} f'(0) + \dots + \frac{1}{k} f'(0) \right\}$$

$$= 1 + \frac{1}{2}(1) + \frac{1}{3}(1) + \dots + \frac{1}{k}(1) \quad [\because f'(0) = 1]$$

$$= 1 + \frac{1}{2} + \frac{1}{3} + \dots + \frac{1}{k}$$

46. We have

$$T(\alpha_1) = T(1, 0, 1) = (4, -2, 3)$$

Now our aim is to express $(4, -2, 3)$ as a linear combination of the vectors in the basis $B = (\alpha_1, \alpha_2, \alpha_3)$.

Let

$$\begin{aligned} (a, b, c) &= x\alpha_1 + y\alpha_2 + z\alpha_3 \\ &= x(1, 0, 1) + y(-1, 2, 1) + z(2, 1, 1) \\ &= (x - y + 2z, 2y + z, x + y + z) \end{aligned}$$

Then $x - y + 2z = a$, $2y + z = b$, $x + y + z = c$

solving these equations, we get

$$x = \frac{-a - 3b + 5c}{4}, y = \frac{b + c - a}{4}, z = \frac{b - c + a}{2} \quad \dots(1)$$

Putting $a = 4$, $b = -2$, $c = 3$ in (1), we get

$$x = \frac{17}{4}, y = -\frac{3}{4}, z = -\frac{1}{2}$$

$$\therefore T(\alpha_1) = \frac{17}{4}\alpha_1 - \frac{3}{4}\alpha_2 - \frac{1}{2}\alpha_3$$

Also $T(\alpha_2) = T(-1, 2, 1) = (-2, 4, 9)$ putting

$$a = -2, b = 4, c = 9 \text{ in (1), we get } x = \frac{35}{4}, y = \frac{15}{4}, z = \frac{-7}{2},$$

$$\therefore T(\alpha_2) = \frac{35}{4}\alpha_1 + \frac{15}{4}\alpha_2 - \frac{7}{2}\alpha_3$$

Finally $T(\alpha_3) = T(2, 1, 1) = (7, -3, 4)$ Putting

$$a = 7, b = -3, c = 4 \text{ in (1), we get } x = \frac{11}{2}, y = -\frac{3}{2}, z = 0$$

$$\therefore T(\alpha_3) = \frac{11}{2}\alpha_1 - \frac{3}{2}\alpha_2 + 0\alpha_3$$

$$\begin{bmatrix} 17/4 & -3/4 & -1/2 \\ 35/4 & 15/4 & -7/2 \\ 11/2 & -3/2 & 0 \end{bmatrix}$$

47. Let $o(p) = p^n, p^{n+1} \mid o(G)$

$$\text{Now } (px) P_i = P_x P_i$$

$$= P_e$$

$$= P$$

[p is normal in $N(P)$ and $x \in N(P)$]

$$\Rightarrow o(P_x) \mid P^i$$

$$\Rightarrow o(P_n) = P^r, \quad j \geq 0$$

$$\text{Let } j > 0, \bar{K} = \langle P_x \rangle \leq N\left(\frac{P}{P}\right)$$

$$\text{s.t. } o(\bar{K}) = P^j$$

$$\text{Since } (\bar{K}) \leq N\left(\frac{P}{P}\right), \bar{K} = \frac{K}{P} \text{ where}$$

$$K \leq N(P)$$

$$P^j = o(k)$$

$$= \frac{o(k)}{o(p)} = \frac{o(k)}{p^n}$$

$$\Rightarrow o(K) = P^{n+j}, \quad j > 0$$

$$\text{But } o(k) \mid o(N(P)) \mid o(G)$$

$$\Rightarrow P^{n+j} \mid o(G), \quad j > 0 \text{ is}$$

a contradiction

$$\therefore j = 0 \Rightarrow o(px) = P^j = 1$$

$$\Rightarrow P_x = P \Rightarrow x \in P.$$

48. (a) Given that $|A| = 1$

$$\text{i.e. } \begin{vmatrix} a & b \\ c & d \end{vmatrix} = 1 \Rightarrow ad - bc = 1$$

then characteristic equation of A is

$$|A - \lambda I| = 0 \Rightarrow \begin{vmatrix} a - \lambda & b \\ c & d - \lambda \end{vmatrix} = 0$$

$$\Rightarrow (a - \lambda)(d - \lambda) - bc = 0$$

$$\Rightarrow ad - bc - \lambda(a + d) + \lambda^2 = 0 \quad [ad - bc =$$

1]

$$\Rightarrow \lambda^2 - \lambda(a + d) + 1 = 0$$

$$\therefore \lambda = \frac{+(a+d) \pm \sqrt{(a+d)^2 - 4}}{2}$$

Since λ is not real if and only if

$$(a + d)^2 - 4 < 0$$

$$\Rightarrow (a + d)^2 < 4$$

(b) Given $f = x^2 - y^2 + 3z^2$

$$\text{Now } \nabla f = 2x\hat{i} - 2y\hat{j} + 6z\hat{k}$$

$$= -2\hat{i} - 4\hat{j} + 6\hat{k} \text{ at } M(-1, 2, +1)$$

$$\text{Also } \vec{MN} = \vec{ON} - \vec{OM} = (3\hat{i} + 5\hat{k}) - (-\hat{i} + 2\hat{j} + \hat{k})$$

$$= 4\hat{i} + 2\hat{j} - 4\hat{k}$$

unit vector along \vec{MN} ,

$$\frac{4\hat{i} + 2\hat{j} - 4\hat{k}}{\sqrt{16 + 4 + 16}} = \frac{4\hat{i} + 2\hat{j} - 4\hat{k}}{6}$$

$$= \frac{1}{3}(2\hat{i} + \hat{j} - 2\hat{k})$$

Therefore, direction derivative of f in the direction \vec{MN}

$$= (\nabla f) \cdot \mathbf{n}$$

$$(-2\hat{i} - 4\hat{j} + 6\hat{k}) \cdot \frac{1}{3}(2\hat{i} + \hat{j} - 2\hat{k})$$

$$\frac{1}{3}(-4 - 4 - 12) = \frac{-20}{3}$$

The direction derivative of f is maximum in the direction of the normal to the given surface.

The magnitude of this maximum

$$\begin{aligned} &= |\nabla f| = \sqrt{(-2)^2 + (-4)^2 + (6)^2} \\ &= \sqrt{56} = 2\sqrt{14} \end{aligned}$$

49. Condition (ii) of the existence of $f^n(c)$ implies that $f, f', f'', \dots, f^{n-1}$ all exist and are continuous at c . Also continuity at c implies the existence of f, f', \dots, f^{n-1} in a certain neighborhood $]c - \delta_1, c + \delta_1[$ of c , ($\delta_1 > 0$).

As $f^n(c) \neq 0$ there exists a neighborhood $]c - \delta, c + \delta[$, ($0 < \delta < \delta_1$) such that for $f^n(c) > 0$,

$$\text{and } \begin{cases} f^{n-1}(x) < f^{n-1}(c) = 0, x \in]c - \delta, c[\\ f^{n-1}(x) > f^{n-1}(c) = 0, x \in]c, c + \delta[\end{cases} \quad (1)$$

and for $f^n(c) < 0$,

$$\text{and } \begin{cases} f^{n-1}(x) > f^{n-1}(c) = 0, x \in]c - \delta, c[\\ f^{n-1}(x) < f^{n-1}(c) = 0, x \in]c, c + \delta[\end{cases} \quad (2)$$

Again for any real number h where $|h| < \delta$ we have by Taylor's Theorem

$$f(c+h) - f(c) = hf'(c) + \frac{h^2}{2!}f''(c) + \dots + \frac{h^{n-1}}{(n-1)!}f^{n-1}(c + \theta h), 0 < \theta < 1$$

$$\text{or } f(c+h) - f(c) = \frac{h^{n-1}}{(n-1)!}f^{n-1}(c + \theta h) \quad (3)$$

where $c + \theta h \in]c - \delta, c + \delta[$.

For n odd: Clearly $h^{n-1} > 0$ for any real number h , and further :

- (i) When $f^n(c) > 0$, we deduce from (1) that for h negative, $(c + \theta h)$ is in $]c - \delta, c[$, and so

$f^{n-1}(c+\theta h) > 0$, and for h positive, $f^{n-1}(c+\theta h) > 0$.

Thus from (3)

$$f(c+h) < f(C), \text{ when } c - \delta < c + h < c$$

and

$$f(c+h) > f(C), \text{ when } c < c + h < c + \delta$$

Thus $f(C)$ is not an extreme value

(ii) when $f^n(C) < 0$, it may similarly be shown that $f(C)$ is not an extreme value.

For n even : As h^{n-1} is positive or negative according to that h is positive or negative, we deduce from (1) and (3) that if $f^n(C) > 0$ then for every point $x = c + h \in]c - \delta, c + \delta[$ except c ,

$$f(c+h) > f(C)$$

i.e. $f(C)$ is a minimum value.

It may similarly be deduced from (1) and (3) that $f(C)$ is a maximum value if $f^n(C) < 0$.

50. (a) Let $h \in H$ and $a \in G$. Then

$$\theta(aha^{-1}) = \theta(a)(h)\theta(a)^{-1} = \theta(a)\theta(a)^{-1}\theta(h)$$

(as G is abelian)

$$= \theta(h)$$

$$\text{Thus } \theta(aha^{-1}h^{-1}) = \theta(a)\theta(h)\theta(a^{-1})\theta(h)^{-1} = e$$

$$\text{so } aha^{-1} \in h^{-1} \text{Ker}\theta \subset H$$

Hence $aha^{-1}H$ and so H is normal.

(b) Let $\mathbf{A} = [a_{ij}]_{n \times n}$

and $\mathbf{B} = [b_{ij}]_{n \times n}$

be two arbitrary elements of \mathbf{W} , then

$$\mathbf{AM} = \mathbf{MA}$$

$$\text{and } \mathbf{BM} = \mathbf{MB}$$

If $x, y \in F$, then

$$\begin{aligned}
 (xA + yB)M &= (xA)M + (yB)M \\
 &= x(AM) + y(BM) \\
 &= x(MA) + y(MB) \\
 &= M(xA) + M(yB) \\
 &= M(xA + yB)
 \end{aligned}$$

This shows that

$$xA + yB \in W$$

i. e., $A, B \in W$

and $x, y \in F$

$$\Rightarrow xA + yB \in W$$

Hence, W is a subspace of $V(F)$.

VPM CLASSES