

TIFR - PHYSICS MOCK TEST PAPER

- Attempt All the 55 Questions (Objective).
- Section A contain 25 Questions, Section B and Section C contain 15 questions each.
- For every correct answer +3 marks, -1 mark for incorrect answer.
- Pattern of questions : MCQs
- Total marks : 165
- Duration of test : 3 Hours

VPM CLASSES

For IIT-JAM, JNU, GATE, NET, NIMCET and Other Entrance Exams

1-C-8, Sheela Chowdhary Road, Talwandi, Kota (Raj.) Tel No. 0744-2429714

Web Site www.vpmclasses.com E-mail-vpmclasses@yahoo.com

Toll Free: 1800-2000-092

Mobile: 9001297111, 9829619614, 9001894073, 9829567114

Website: www.vpmclasses.com

FREE Online Student Portal: examprep.vpmclasses.com

E-Mail: vpmclasses@yahoo.com / info@vpmclasses.com

Page 1

SECTION -A(1-25)

1. White light is incident on a soap film at an angle $\sin^{-1}(4/5)$ and the reflected light on examination by a spectroscope shows dark bands. Two consecutive dark bands corresponds to wavelengths 6.1×10^{-5} and 6.0×10^{-5} cm. If the refractive index of the film be $4/3$, the thickness is
 - (A) 17cm
 - (B) 1.7 cm
 - (C) 0.017 cm
 - (D) 0.0017 cm

2. A galvanometer together with an unknown resistance in series is connected across two identical batteries each 1.5V. When the batteries are connected in series, the galvanometer records a current of 1 A, and when the batteries are in parallel the current is 0.6 A. What is the internal resistance of the battery?
 - (A) $\frac{21}{10} \Omega$
 - (B) $\frac{2}{9} \Omega$
 - (C) $\frac{1}{6} \Omega$
 - (D) $\frac{1}{3} \Omega$

3. A pith ball covered with tinfoil having a mass of m kg hangs by a fine silk thread ℓ meter long in an electric field E . When the ball is given an electric charge of q coulomb, it stands out d metre from the vertical line. Then the electric field is given by

(A) $E = mg d / \alpha \sqrt{(\ell^2 - d^2)}$.

(B) $\frac{mgd}{q\ell}$

(C) $\frac{mgd}{q(\ell^2 - d^2)}$

(D) $\frac{mgd}{\alpha(\ell^2 - d^2)^{3/2}}$

4. A metallic cylindrical vessel whose inner and outer radii are r_1 and r_2 is filled with ice at 0°C . The mass of the ice in the cylinder is m . Circular portion of the cylinder is sealed with completely adiabatic walls. The vessel is kept in air. Temperature of the air is T . How long will it take for the ice to melt completely. Thermal conductivity of the cylinder is K and length is ℓ .

(A) $\frac{mL \log_e (r_2/r_1)}{\pi k \ell T}$

(B) $\frac{mL \log_e (r_2/r_1)}{2\pi k \ell T}$

(C) $\frac{mL \log_e (r_1/r_2)}{2\pi k \ell T}$

(D) $\frac{mL \log_e (r_1/r_2)}{\pi k \ell T}$

5. An ideal gas at 75 cm mercury pressure is compressed isothermally until its volume is reduced to three quarters of its original volume. It is then allowed to expand adiabatically to a volume 20% greater than its original volume. If the initial temperature of the gas is 17°C , The final pressure and temperature ($\gamma = 1.5$) is

(A) 49.4 cm of mercury, 229.3°C

(B) 49.4 cm of mercury, 43.7°C

(C) 49.4 cm of mercury, -43.7°C

(D) 44.9 cm of mercury, -47.3°C

6. Matrix, $A = \alpha \begin{bmatrix} 2 & -2i & 0 \\ 2i & -2 & 0 \\ 0 & 0 & 1 \end{bmatrix}$, where α is scalar is given then find value of α for which A

is unitary.

(A) $\frac{1}{\sqrt{2}}$

(B) $\frac{1}{2}$

(C) $\frac{1}{2\sqrt{2}}$

(D) $\frac{1}{4}$

7. The trigonometric Fourier series for the waveform $f(t)$ shown below contains

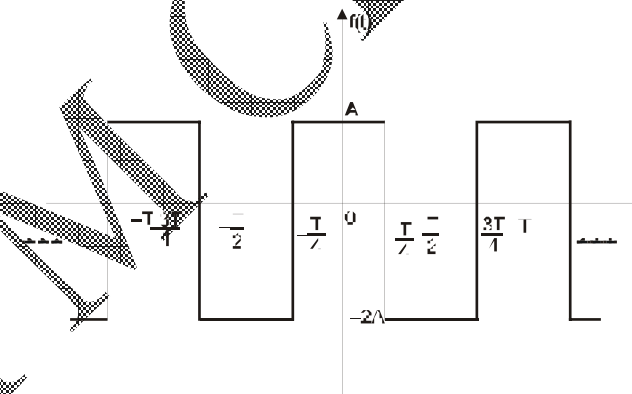

(A) only cosine terms and zero value for the dc component

(B) only cosine terms and a positive value for the dc component

(C) only cosine terms and a negative value for the dc component

(D) only sine terms and a negative value for the dc component

8. A function $n(x)$ satisfies the differential equation $\frac{d^2n(x)}{dx^2} - \frac{n(x)}{L^2} = 0$ where L is a constant. The boundary conditions are $n(0) = K$ and $n(\infty) = 0$.

The solution to this equation is

- (A) $n(x) = K \exp(x/L)$
 (B) $n(x) = K \exp(-x/\sqrt{L})$
 (C) $n(x) = K^2 \exp(-x/L)$
 (D) $n(x) = K \exp(-x/L)$
9. In the silicon BJT circuit shown below, assume that the emitter area of transistor Q1 is half that of transistor Q2.

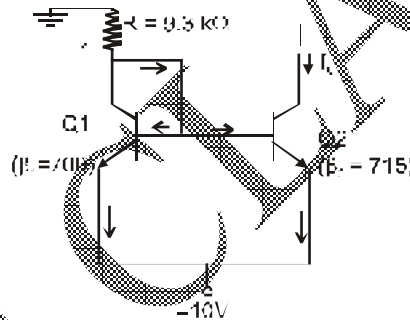

The value of current I_0 is approximately

- (A) 0.5 mA
 (B) 2 mA
 (C) 93 mA
 (D) 15 mA
10. The transfer characteristic for the precision rectifier circuit shown below is (assume ideal OPAMP and practical diodes)

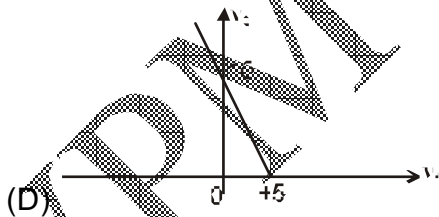
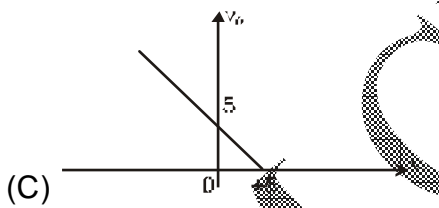
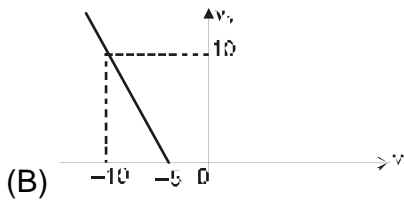
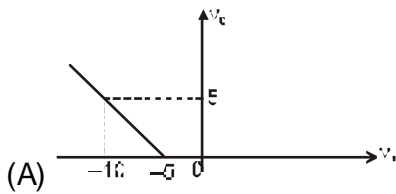
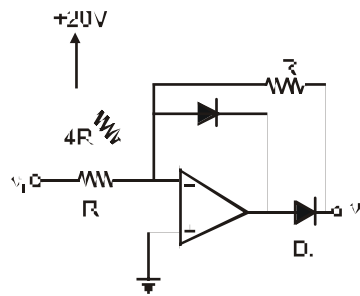

11. The asymptotic solution of the equation $\frac{\partial^2 \psi}{\partial q^2} - q^2 \psi = 0$ [$q^2 \geq \lambda$] in the case of one-dimensional linear harmonic oscillator is given by

(A) $e^{-q^2/2}$

- (B) $e^{+q^2/2}$
 (C) both (A) and (B)
 (D) none of these

12. The mean effective pressure, p_m' for the Otto cycle is

(Where $p_3 = p_{\max}$, $p_1 = p_{\min}$ and r_k is compression ratio.)

(A)
$$p_M = \frac{(p_3 - p_1 r_c^\gamma) \left(1 - \frac{1}{r_c^{\gamma-1}}\right)}{(\gamma - 1)(r_c - 1)}$$

(B)
$$p_M = \frac{(p_1 - p_3 r_c^\gamma) \left(1 - \frac{1}{r_c^{\gamma-1}}\right)}{(r - 1)(r_c - 1)}$$

(C)
$$p_M = \frac{(p_3 p_1 r_c^r)(1 - r_c^{r-1})}{(r - 1)(r_c - 1)}$$

(D)
$$p_M = \frac{(p_1 - p_3 r_c^r) r_c^{r-1}}{(r - 1)(r_c - 1)}$$

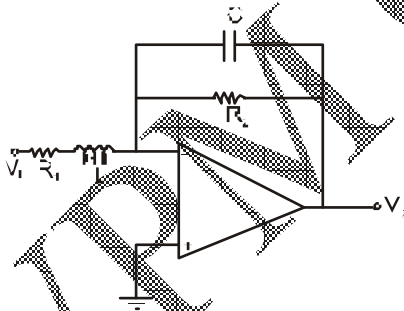

13.

The OPAMP circuit shown above represents a

- (A) high pass filter
 (B) low pass filter
 (C) band pass filter

(D) band reject filter

14. Which of the following is not an assumption in Drude-Lorentz theory of free electrons?
- (A) Metals contain free electrons that move through a lattice of positive ions.
 (B) Electric field produced by lattice ions is considered to be uniform throughout the solid and hence neglected.
 (C) Free electrons in a metal resemble molecules of a gas and therefore the laws of kinetic theory of gases are applicable to free electrons.
 (D) The electrons are distributed among the energy levels according to Pauli's exclusion principle.
15. Laser beam production is based on the principle of
- (A) Induced Absorption
 (B) Spontaneous emission
 (C) Ionization
 (D) Stimulated emission
16. If the temperature of the blackbody is halved the wavelength corresponding to the maximum emission of radiation becomes
- (A) 2 times
 (B) 4 times
 (C) $\frac{1}{2}$ times
 (D) $\frac{1}{4}$ times

17. The concepts of a "particle" and a "wave"
- (A) are clear and completely distinct from one another in both classical and modern physics.
- (B) can both be applied to electromagnetic radiation.
- (C) have found little use in quantum physics.
- (D) all of the above are true.
18. A network of wires carrying various currents is shown in the figure given below. What is the current through the ammeter A?

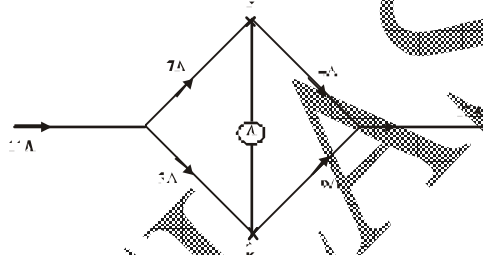

- (A) Zero
- (B) 2 A
- (C) 3 A
- (D) 9 A
19. The Heisenberg's uncertainty principle is expressed as

(A) $\Delta x \cdot \Delta p_z \leq \frac{h}{4\pi}$

(B) $\Delta x \cdot \Delta p_z \leq \frac{h}{4\pi}$

(C) $\Delta x \cdot \Delta p_x \geq \frac{h}{4\pi}$

(D) $\Delta x \cdot \Delta p_x \leq \frac{h}{4\pi}$

20. The resistivity of conductors

- (A) decreases as the temperature decreases
- (B) decreases as the temperature increases
- (C) increases as the temperature decreases
- (D) independent of temperature

21. The energy of a linear harmonic oscillator in third excited state is 0.1 eV. Then what is the frequency of vibration.

- (A) 3.30×10^{14} Hz
- (B) 33.0×10^{14} Hz
- (C) 3.304×10^{13} Hz
- (D) 33.04×10^{15} Hz

22. Find the rank of the matrix $A = \begin{vmatrix} 1 & 3 & 5 & 1 \\ 2 & 4 & 8 & 0 \\ 3 & 1 & 7 & 5 \end{vmatrix}$.

- (A) 2
- (B) 3
- (C) 4
- (D) none of these

23. Consider two independent random variables X and Y with identical distributions. The variables X and Y take values 0, 1 and 2 with probabilities $\frac{1}{2}, \frac{1}{4}$ and $\frac{1}{4}$ respectively. What is the conditional probability $P(X + Y = 2 | X - Y = 0)$?

(A) 0

(B) $\frac{1}{16}$

(C) $\frac{1}{6}$

(D) 1

24. Consider the matrix $P = \begin{bmatrix} 0 & 1 \\ -2 & -3 \end{bmatrix}$. The value of e^P is

(A) $\begin{bmatrix} 2e^{-2} - 3e^{-1} & e^{-1} - e^{-2} \\ 2e^{-2} - 2e^{-1} & 5e^{-2} - e^{-1} \end{bmatrix}$

(B) $\begin{bmatrix} e^{-1} + e^{-2} & 2e^{-2} - e^{-1} \\ 2e^{-1} + 4e^{-2} & 3e^{-1} - 2e^{-2} \end{bmatrix}$

(C) $\begin{bmatrix} 5e^{-2} + e^{-1} & 3e^{-1} - e^{-2} \\ 2e^{-1} - 6e^{-1} & 4e^{-2} + e^{-1} \end{bmatrix}$

(D) $\begin{bmatrix} 2e^{-1} - e^{-2} & e^{-1} - e^{-2} \\ -2e^{-1} + 2e^{-2} & 2e^{-2} - e^{-1} \end{bmatrix}$

25. A rigid body is rotating with constant angular velocity ω , then linear velocity v is

(A) solenoidal

(B) constant

(C) zero

(D) cannot say anything

SECTION -B(26-40)

26. Rest mass energy of an electron is 0.51 MeV. A moving electron has a kinetic energy of 9.69 MeV. The ratio of the mass of the moving electron to its mass is

(A) 19 : 1

(B) 20 : 1

(C) 1 : 19

(D) 1 : 20

27. Find out the output voltage in the circuit of fig.

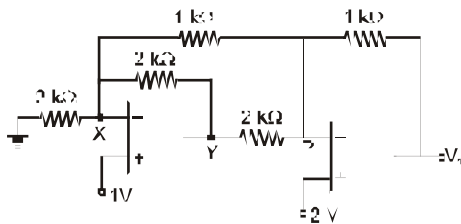

(A) 1 volt

(B) 2 volt

(C) 3 volt

(D) 4 volt

28. A Carnot's engine using 100 gm. water-steam as working substance has, at the beginning of the stroke, volume 104 c.c. and pressure 788 mm. (B.P. = 101°C). After a complete isothermal pressure is then lowered adiabatically to 733.7 mm. (B.P. = 90°C). If the engine is working between 99°C and 101°C, the latent heat of steam is

(A) 540.0 cal/gm

(B) 450.0 cal/gm

(C) 520 cal/gm

(D) 490 cal/gm

29. Which one of the following reaction are forbidden under the conservation of strangeness, conservation of baryon number and conservation of charge

(A) $\pi^+ + n \rightarrow \Lambda^0 + K^+$

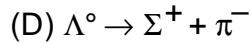
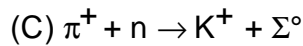
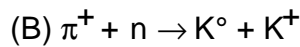

30. Assume that the center of mass of a girl crunching in a light swing has been raised to 1.2 m. The girl weights 400 N, and her center of mass is 3.7 m from the pivot of the swing while she is in the crouched position. The swing is released from rest, and at the bottom of the arc the girl stands up instantaneously, thus raising her center of mass 0.6 m (returning it to its original level). Find the height of her center of mass at the top of the arc.
- (A) 4.1 m
 (B) 4.1 cm
 (C) 2.04 m
 (D) 3.5 m
31. When one leg of a Michelson interferometer is lengthened slightly, 150 dark fringes sweep through the field of view. If the light used has $\lambda = 480$ nm, how far was the mirror in that leg moved ?
- (A) 0.600 mm
 (B) 0.360 mm
 (C) 0.006 mm
 (D) 0.036 mm
32. The rectangular loop shown in Fig. moves toward the origin at a velocity $U = -250a_y$ m/s in a field

$$B = 0.80e^{-0.50y} a (T)$$

Find the current at the instant the coil sides are at $y = 0.50$ m and 0.60 m, if $R = 2.5 \Omega$.

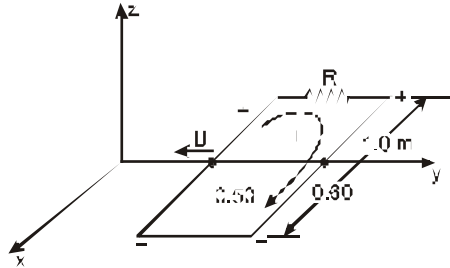

- (A) 4.03 A
- (B) 3.55 A
- (C) 3.04 A
- (D) 2.92 A

33. If the z -component of an electron spin is $+\hbar/2$ and its component along with the z' -axis equals $+\hbar/2$ and $-\hbar/2$ (see fig). What is the average value of the spin along z' ?

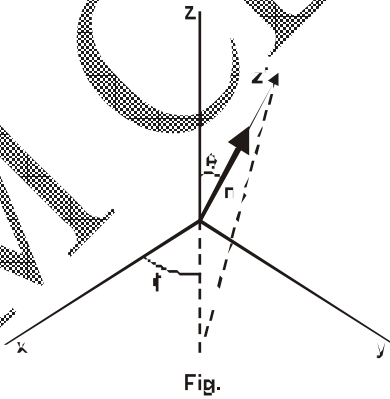

(A) $\hbar \cos^2 \frac{\theta}{2}$

(B) $\hbar \sin^2 \frac{\theta}{2}$

(C) $\frac{\hbar \sin \theta}{2}$

(D) $\frac{\hbar \cos \theta}{2}$

34. What is the potential difference between two points distant r_1 and r_2 from an infinitely long line charge of linear charge density (i.e. charge per unit length) λ .

(A) $\frac{1}{4\pi\epsilon_0} \frac{2\lambda r_1}{r_2^2}$

(B) $\frac{1}{4\pi\epsilon_0} 2\lambda \log_e \left(\frac{r_2}{r_1} \right)$

(C) $\frac{1}{4\pi\epsilon_0} 2\lambda \log_e \left(\frac{r_1}{r_2} \right)$

(D) $\frac{1}{4\pi\epsilon_0} 2\lambda \exp \left(-\frac{r_1}{r_2} \right)$

35. If $\vec{B} = \nabla \times \vec{A}$, then what is the value of $\oint \vec{B} \cdot d\vec{\sigma}$ for a closed surface?

(A) 0

(B) 1

(C) -1

(D) Infinity

36. Two infinite plane sheets are placed parallel to each other, separated by distance d . The lower sheet has a uniform positive surface charge density σ and the upper sheet has uniform negative surface charge density $-\sigma$ with the same magnitude then, what is the electric field between the two sheets, above the upper sheet, and below the lower sheet.

(A) $0, \frac{\sigma}{2\epsilon_0}, \frac{\sigma}{2\epsilon_0}$

(B) $\frac{\sigma}{\epsilon_0}, 0, 0$

(C) $0, \frac{\sigma}{\epsilon_0}, \frac{\sigma}{\epsilon_0}$

(D) $\frac{\sigma}{2\epsilon_0}, \frac{\sigma}{\epsilon_0}, \frac{\sigma}{\epsilon_0}$

37. Consider the operator A, B satisfies following relation $[A, B^n] = n[A, B] B^{n-1}$ for every analytic function (in term of power series) F(x) what is the value of $[A, F(B)]$

(A) $[A, B] F(B)$

(B) $[A, B] F'(B)$

(C) $[A, B] F(B) + F(B)[B, A]$

(D) none of these

Where $F'(B)$ is derivative of $F(B)$

38. Using the basis vectors of S_z , What is value of eigen vectors of S^2

(A) $\frac{3\hbar^2}{2} \begin{bmatrix} 1 & 0 \\ 0 & -1 \end{bmatrix}$

(B) $\frac{3\hbar^2}{2} \begin{bmatrix} 1 & 0 \\ 0 & 1 \end{bmatrix}$

(C) $\frac{3\hbar^2}{4} \begin{bmatrix} 1 & 0 \\ 0 & 1 \end{bmatrix}$

(D) $\frac{\hbar^2}{2} \begin{bmatrix} 0 & 1 \\ 1 & 0 \end{bmatrix}$

39. Let ϕ_1 and ϕ_2 be orthonormal functions find the value of n which normalizes the function $f = n(\phi_1 + 2i\phi_2)$

(A) $n = (1 + 2i)$

(B) $n = \frac{1}{(1+2i)}$

(C) $n = \frac{1}{5}$

(D) $n = \frac{1}{\sqrt{5}}$

40. The residue of the function, $f(z) = \frac{z}{\cos z}$ is

(A) $(-1)^{n+1}(2n+1)\frac{\pi}{2}$

(B) $\frac{3}{2}(-1)^{n+1}(2n-1)\pi$

(C) $2\pi i(-1)^{n+1}(2n+1)\pi/2$

(D) $-2\pi i(-1)^{n+1}\frac{\pi}{2}$

SECTION C (41-55)

41. The elementary particles can be grouped into two broad categories differentiated from each other by a property called _____

- (A) Momentum
- (B) Spin
- (C) Acceleration
- (D) Direction

42. If every element of a group G is its own inverse, then G is

- (A) Finite
- (B) Infinite

- (C) Cyclic
(D) Abelian
43. A bullet is fired horizontally in the north direction with a velocity of 500 m/sec at 30° N latitude. Calculate the horizontal component of Coriolis acceleration
- (A) 0.36 m/sec^2
(B) 0.036 m/sec^2
(C) 0.24 m/sec^2
(D) 7.2 m/sec^2
44. Find the rank of the matrix $A = \begin{vmatrix} 1 & 3 & 5 & 1 \\ 2 & 4 & 8 & 0 \\ 3 & 1 & 7 & 5 \end{vmatrix}$.
- (A) 2
(B) 3
(C) 4
(D) none of these
45. Considering six subintervals, the value of $\int_0^6 \frac{dx}{1+x^2}$ by Simpson's rule, is
- (A) 1.3562
(B) 1.3662
(C) 1.3456
(D) 1.2662
46. Let D_n be the nth order determinant given by

$$D_n = \begin{bmatrix} 1 & 1 & 0 & 0 & 0 & \dots & \dots & \dots & 0 \\ 1 & 1 & 1 & 0 & 0 & \dots & \dots & \dots & 0 \\ 0 & 1 & 1 & 1 & 0 & \dots & \dots & \dots & 0 \\ \dots & \dots & \dots & \dots & \dots & \dots & \dots & \dots & \dots \\ \dots & \dots & \dots & \dots & \dots & \dots & \dots & \dots & \dots \\ 0 & 0 & \dots & \dots & \dots & 0 & 1 & 1 & 1 \\ 0 & 0 & \dots & \dots & \dots & 0 & 0 & 1 & 1 \end{bmatrix}$$

for n symbol, D_{3k} will be

- (A) $(-1)^k$
- (B) $(-1)^{k-1}$
- (C) $(-1)^{k+1}$
- (D) none of these

47. What is the ground-state electron energy E_1 by substituting the radial wave function R that corresponds to $n = 1, \ell = 0$

- (A) $\frac{-\hbar^2}{2ma_0^2}$
- (B) $\frac{-\hbar^2}{ma_0^2}$
- (C) $\frac{-\hbar^2}{ma_0}$
- (D) $\frac{-\hbar^2}{4ma_0^2}$

48. What would be the grand canonical partition function for a classical ideal gas –

- (A) $\sum_N \frac{1}{N!} [e^{\beta\mu} Z(T)]^N$
- (B) $\sum_N \frac{1}{N!} [e^{\beta\mu} Z^N(T)]$
- (C) $\sum_N \frac{1}{N!} [e^{\beta\mu N} Z(T)]$

$$(D) \sum_N \frac{1}{N!} [e^{\beta u} Z(T)]^N$$

49. The velocity of a train which starts from rest is given by the following table, the time being reckoned in minutes from the start and the speed in km/hour.

t (minutes)	2	4	6	8	10	12	14	16	18	20
v (km/hr)	16	28.8	40	46.4	51.2	32	17.6	8	3.2	0

Estimate approximately the total distance run in 20 minutes.

- (A) 8.25 km
 (B) 8.25 m
 (C) 8.15 km
 (D) 8.15 m
50. The p.d.f. of a continuous random variate is

$$f(x) = \begin{cases} 0, & x < 2 \\ \frac{(3+2x)}{18} & 2 \leq x \leq 4 \\ 0, & x > 4 \end{cases}$$

Then probability that x will lie between is :

- (A) 4/9
 (B) 2/9
 (C) 5/9
 (D) -2/9
51. At the interface between two linear dielectrics (with dielectric constants ϵ_1 and ϵ_2), the electric field lines bend as shown in the figure. Assume that there are no free charges at the interface. The ratio ϵ_1/ϵ_2 is

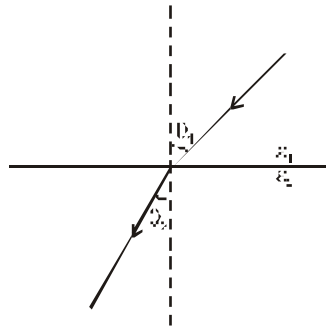

- (A) $\frac{\tan \theta_1}{\tan \theta_2}$
 (B) $\frac{\cos \theta_1}{\cos \theta_2}$
 (C) $\frac{\sin \theta_1}{\sin \theta_2}$
 (D) $\frac{\cot \theta_1}{\cot \theta_2}$

52. What is the value of $\frac{d}{dx} \{x J_1(x)\}$

- (A) $x^2 J(x)$
 (B) $x J_0(x)$
 (C) $2^x J_0(x)$
 (D) $x J_1(x)$

53. $(x+1) \frac{dy}{dx} - 2(x+3)y = e^x$, Calculate C.F. solution of the differential equation.

- (A) $y = x$
 (B) $y = e^x$
 (C) $y = e^{2x}$

(D) $y = Xe^X$

54. Recall that $b \sim \frac{\lambda}{4} \sim \frac{\pi}{2K}$ for the ground level of the deuteron. then the radius of deuteron, in the rectangular well model is approximately-

(A) $R = \frac{2bV_0^{\frac{1}{2}}}{\pi B^{\frac{1}{2}}}$

(B) $R = \frac{bV_0^{\frac{1}{2}}}{\pi B^{\frac{1}{2}}}$

(C) $R = \frac{bV_0^{\frac{1}{2}}}{\pi B}$

(D) $R = \frac{2bV_0}{\pi B}$

55. What is the expression of net force on the "bowl" hemisphere of a uniformly charged solid sphere of radius R and charge Q.

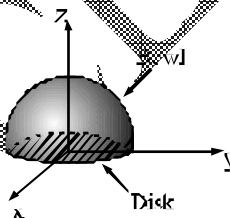

Fig.

(A) $F = \frac{1}{4\pi\epsilon_0} \frac{5Q^2}{16R^2}$

(B) $F = \frac{1}{4\pi\epsilon_0} \frac{3Q^2}{16R^2}$

(C) $F = \frac{1}{4\pi\epsilon_0} \frac{Q^2}{16R^2}$

(D) $F = \frac{1}{4\pi\epsilon_0} \frac{Q^2}{8R^2}$

ANSWER KEY

Question	1	2	3	4	5	6	7	8	9	10	11	12	13	14	15	16	17	18	19	20
Answer	D	D	A	B	C	C	C	D	B	A	A	A	B	D	D	A	B	C	C	A
Question	21	22	23	24	25	26	27	28	29	30	31	32	33	34	35	36	37	38	39	40
Answer	C	B	C	D	A	B	D	A	B	C	D	C	D	B	A	B	B	C	D	A
Question	41	42	43	44	45	46	47	48	49	50	51	52	53	54	55					
Answer	B	D	B	B	B	A	A	D	A	A	A	B	B	A	D					

HINTS AND SOLUTION

1.(D) For dark bands in the reflected light

$$2\mu t \cos r = n\lambda$$

When the observed dark bands are consecutive, their orders will differ by one. Let n and $(n + 1)$ be the orders of dark bands due to wavelengths λ_1 and λ_2 respectively.

$$\text{Then } 2\mu t \cos r = n\lambda_1 = (n + 1)\lambda_2$$

$$\text{or } n = \frac{\lambda_2}{\lambda_1 - \lambda_2}$$

$$\therefore 2\mu t \cos r = \frac{\lambda_1 \lambda_2}{\lambda_1 - \lambda_2}$$

$$t = \frac{\lambda_1 \lambda_2}{2\mu \cos r \times (\lambda_1 - \lambda_2)}$$

Here $\lambda_1 = 6.1 \times 10^{-5}$, $\lambda_2 = 6.0 \times 10^{-5}$, $\mu = \frac{4}{3}$ and $\sin i = \frac{4}{5}$

$$\cos r = \sqrt{1 - \sin^2 r} = \sqrt{1 - (\sin i / \mu)^2} = \frac{\sqrt{(\mu^2 - \sin^2 i)}}{\mu}$$

$$\text{Now } t = \frac{\lambda_1 \lambda_2 \mu}{2\mu \sqrt{\mu^2 - \sin^2 i} \times (\lambda_1 - \lambda_2)}$$

$$= \frac{\lambda_1 \lambda_2}{2\sqrt{(\mu^2 - \sin^2 i) \times (\lambda_1 - \lambda_2)}}$$

$$= \frac{(6.1 \times 10^{-5})(6.0 \times 10^{-5})}{2 \times \sqrt{\left(\frac{16}{9} - \frac{16}{25}\right) \times (0.1 \times 10^{-5})}} = 0.0017 \text{ cm.}$$

2.(D) The two internal resistance are in parallel. Hence their effective resistance is $r/2$.
Now

$$\text{current} = \frac{E}{(R + R') + r/2} \quad \dots(1)$$

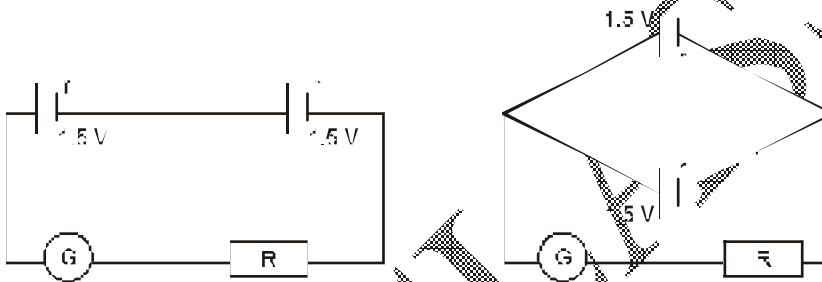

$$\text{or } 0.6 = \frac{E}{(R + R') + r/2} \quad \text{or } 0.6 = \frac{1.5}{(3 - 2r) + r/2} \quad [\because R + R' = (3 - 2r)]$$

$$\text{Solving we get, } r = \frac{1}{3} \text{ ohm.}$$

3.(A) As shown in figure the following forces act on the ball when it is in equilibrium
(i) weight mg acting vertically downward

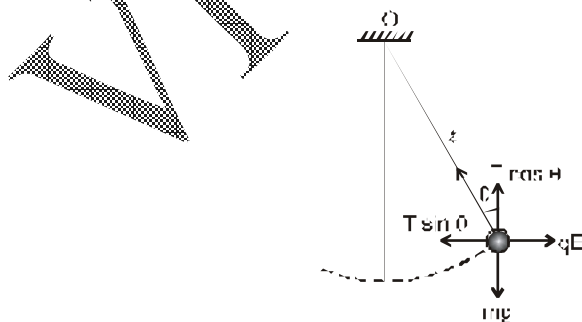

(ii) Tension T in the thread

(iii) Electric force qE horizontally to the right.

From figure $T \sin \theta = qE$

and $T \cos \theta = mg$

$$\therefore \tan \theta = \frac{qE}{mg}$$

$$\text{or } E = \frac{mg}{q} \cdot \tan \theta$$

$$\text{But, } \tan \theta = \frac{d}{\sqrt{(\ell^2 - d^2)}}$$

$$\therefore E = \frac{mg}{q} \frac{d}{\sqrt{(\ell^2 - d^2)}}$$

4.(B)

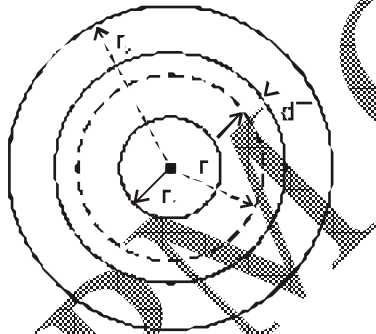

For elementary ring

$$\frac{dq}{dt} = KA \frac{dT}{dr} = K2\pi r \ell \frac{dT}{dr}$$

$$\text{or } H \left(\frac{dr}{K.2\pi r \ell} \right) = dT \quad \left(\text{Where } \frac{dq}{dt} = H \right)$$

integrating for the cylinder, we get

$$\frac{H}{K 2 \pi \ell} \int_{r_1}^{r_2} \frac{dr}{r} = \int_0^T dT$$

or
$$\frac{H}{K 2 \pi \ell} \log_e \left(\frac{r_2}{r_1} \right) = T$$

or
$$H = \frac{T K 2 \pi \ell}{\log_e (r_2 / r_1)} \quad (1)$$

If t be the time taken by the ice to melt, then

$$Ht = mL \text{ or } t = (mL/H) \quad (2)$$

Substituting the value of H from equation (1) in equation (2), we get

$$t = \frac{mL \log_e (r_2 / r_1)}{2 \pi K \ell T}$$

5.(C) First of all the gas is compressed isothermally. Using Boyle's law

$$P_1 V_1 = P_2 V_2$$

or
$$P_2 = (P_1 V_1 / V_2)$$

Here $P_1 = 75$ cm of mercury and $V_2 = \frac{3}{4} V_1$

$$\therefore P_2 = \frac{75 V_1}{(3/4) V_1} = 100 \text{ cm mercury}$$

The gas is now expanded adiabatically to 20% of its original value. Under adiabatic change

$$P_2 V_2 = P_3 V_3^\gamma$$

or
$$P_3 = P_2 \left(\frac{V_2}{V_3} \right)^\gamma$$

Here $V_2 = \frac{3}{4} V_1$ and $V_3 = \frac{120}{100} V_1$

$$\begin{aligned} \therefore P_3 &= 100 \times \left(\frac{3V_1}{4}\right)^{1.5} \times \left(\frac{100}{120V_1}\right)^{1.5} \\ &= 100 \times \left(\frac{3}{4}\right)^{1.5} \times \left(\frac{5}{6}\right)^{1.5} = 100 \times \left(\frac{5}{8}\right)^{1.5} = 100 \times 0.494 = 49.4 \text{ cm of mercury} \end{aligned}$$

Let the final temperature after adiabatic change be T_3 °K

$$\text{Now } T_2 V_2^{\gamma-1} = T_3 V_3^{\gamma-1}$$

$$T_2 = 17^\circ\text{C} = (273 + 27) = 290^\circ\text{K}$$

$$\begin{aligned} \text{Now } T_3 &= T_2 \left(\frac{V_2}{V_3}\right)^{\gamma-1} = 290 \times \left(\frac{3V_1}{4}\right)^{1.5-1} \times \left(\frac{100}{120V_1}\right)^{1.5-1} \\ &= 290 \times \left(\frac{5}{8}\right)^{0.5} = 229.3^\circ\text{K} \end{aligned}$$

Hence the final temperature will be -43.7°C

$$6.(C) \quad A^\dagger = (A^T)^* = \alpha \begin{pmatrix} 2 & +2i & 0 \\ -2i & -2 & 0 \\ 0 & 0 & 1 \end{pmatrix}^* = A^\dagger A = \alpha^2 \begin{pmatrix} 2 & -2i & 0 \\ 2i & -2 & 0 \\ 0 & 0 & 1 \end{pmatrix} \begin{pmatrix} 2 & -2i & 0 \\ -2i & -2 & 0 \\ 0 & 0 & 1 \end{pmatrix}$$

$$= \alpha^2 \begin{pmatrix} 4+4+0 & = 4\hat{i}+4\hat{i}+0 & 0+0+0 \\ 4-4\hat{i}+0 & +4+4+0 & 0+0+0 \\ 0+0+0 & 0+0+0 & -0+0+1 \end{pmatrix}$$

$$1 = \alpha^2 \begin{pmatrix} 8 & 0 & 0 \\ 0 & 8 & 0 \\ 0 & 0 & 8 \end{pmatrix} \Rightarrow 8\alpha^2 \begin{pmatrix} 1 & 0 & 0 \\ 0 & 1 & 0 \\ 1 & 0 & 1 \end{pmatrix} = 1$$

$$\Rightarrow \alpha^2 = \frac{1}{8} \text{ or } \alpha = \frac{1}{\sqrt{8}} = \frac{1}{2\sqrt{2}}$$

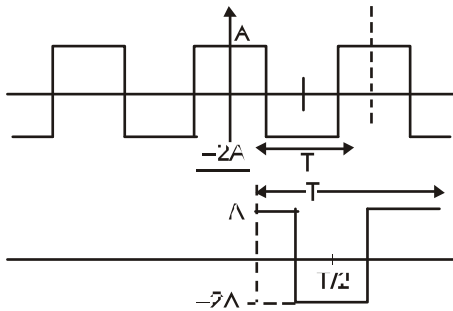

7.(C)

Since negative part has amplitude = $2A$

\therefore dc value = (-ve)

and since it is symmetrical about y axis, therefore only cosine terms.

Alternately,

For given waveform

$$f(t) = f(-t) \text{ [even symmetry]}$$

and Area below x-axis > Area above x-axis

So, Fourier series will contain only cosine terms and negative value of area (d.c. component).

8.(D) Given: $\frac{d^2n(x)}{dx^2} - \frac{n(x)}{L^2} = 0$

where $L = \text{constant}$

Boundary conditions are: $n(0) = K$

and $n(\infty) = 0$

$$\therefore \left(p^2 - \frac{1}{L^2} \right) = 0$$

$$\Rightarrow p = + \frac{1}{L}$$

$$\therefore n(x) = A_1 e^{-\frac{1}{L}x} + A_2 e^{\frac{1}{L}x}$$

Applying Boundary conditions:

$$n(0) = A e^0 = A_1 + A_2 = k$$

and $n(\infty) = A_1 \cdot 0 + A_2 e^\infty = 0$

$$\Rightarrow A_1 = k$$

Hence solution is $n(x) = k e^{-\frac{1}{L}x}$

9.(B)

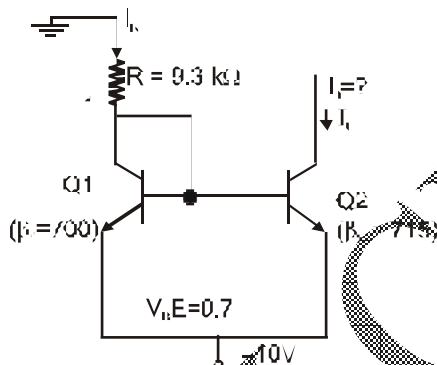

Let both transistors are in active region, therefore voltage at Q_1 base

$$(V_{\text{Base}})_{Q1} = 0.7 - 10 = -9.3 \text{ V}$$

Current through R,

$$I_R = \frac{9.3 \text{ V}}{9.3 \text{ k}\Omega} = 1 \text{ mA}$$

$$= I_C$$

Since emitter area of $Q_1 = \frac{1}{2}$ [emitter area of Q_2]

i.e. $A_{Q1} = \frac{A_{Q2}}{2}$

$\therefore (\beta_2)_{\text{effective}} = 2 \times \beta_2 = 1430$

Since effective β of Q_2 is double of Q_1 , so collector current also will be double nearly.

$$I_{C2} \approx 2 \times I_{C1}$$

$$\approx 2 \text{ mA}$$

10.(A) Since input is connected to negative terminal, so output will always be (+ve)

Since $V_A = 0$ (virtually grounded)

Case 1: $i_1 + i_2 + i_3 = i$

$$\therefore \frac{20}{4R} + \frac{v_i}{R} + \frac{v_o}{R} = i$$

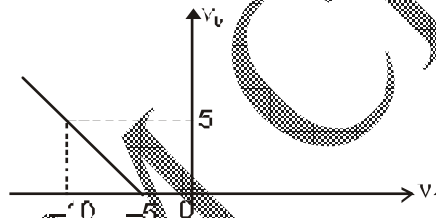

If $v_0 = +ve$, diode does not conduct, so, $i = 0$

$$\therefore \frac{20}{4R} + \frac{v_i}{R} + \frac{v_o}{R} = 0$$

$$5 + v_i + v_0 = 0$$

$$\Rightarrow v_0 = -5 - v_i \quad v_i \geq 0$$

$$\Rightarrow v_i \leq -5$$

Case 2: Since diode will conduct, hence

For $v_i > -5$, $v_0 = 0$

For input $v_i = -10$, $v_0 = -5 + 10 = +5$ volts

Alternately

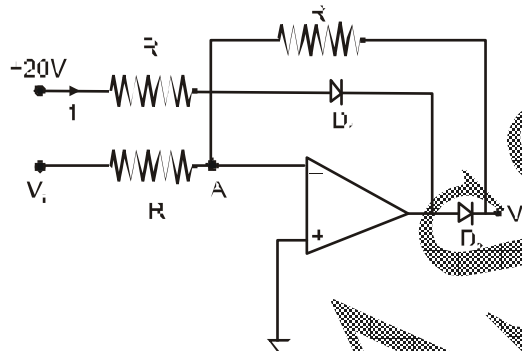

Point A will be at zero volt, so 20V source supply current,

$$I = \frac{20}{R}$$

Case 1: $v_0 \geq 0$,

v_0 will supply current

D_1 and D_2 will be in forward bias, so

$$v_0 = 0$$

Case 2: $-5 > v_i < 0$,

+20V source will supply current to both V_i source and circuit and diodes D_1 and

D_2 will still in forward bias. So

$$\therefore v_0 = 0$$

Case 3: $v_i < -5$,

So v_i will sink current more than $\frac{20}{R} = I$

So, D_1 and D_2 will be in reverse bias

$$\therefore v_0 \propto v_i$$

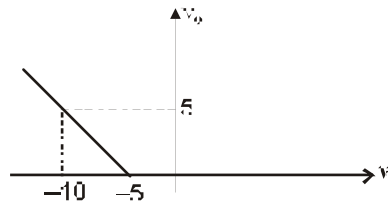

So

$$11.(A) \quad \frac{\partial^2 \psi}{\partial q^2} - q^2 \psi = 0 \quad [q^2 \geq \lambda] \quad \dots(1)$$

where $\lambda = 2e\sqrt{\frac{m}{h^2 K}}$

The solution of eq (1) is

$$\psi = e^{\pm q^2/2}$$

So $\psi_1 = e^{q^2/2}, \psi_2 = e^{-q^2/2}$

But the solution $\psi_1 = e^{q^2/2}$ is not acceptable since it increases with increasing x i.e. q , while the solution $\psi_2 = e^{-q^2/2}$ satisfies the condition and therefore is an asymptotic solution of the value equation (1).

12.(A) Take p_1, v_1, T_1

$$\therefore \frac{T_2}{T_1} = \left(\frac{p_2}{p_1}\right)^{\frac{\gamma-1}{\gamma}} = \left(\frac{V_1}{V_2}\right)^{\gamma-1} = r_c^{\gamma-1}$$

$$\therefore T_2 = T_1 \cdot r_c^{\gamma-1}$$

$$p_2 = p_1 \times r_c^{\gamma-1}$$

$$v_2 = \frac{V_1}{r_c}$$

$$\frac{p_3}{T} = \frac{p_2}{T}$$

$$\therefore T_3 = T_2 \frac{p_3}{p_2} = T_2 \times \frac{p_3}{p_1 r_c^\gamma} = T_1 \frac{r_c^{\gamma-1} \times p_3}{p_1 r_c^\gamma} = \frac{T_1 \times p_3}{r_c p_1}$$

$$\frac{T_3}{T_4} = \left(\frac{V_4}{V_3}\right)^{\gamma-1} \left(\frac{V_1}{V_2}\right)^{\gamma-1} = r_c^{\gamma-1}$$

$$\therefore T_4 = \frac{T_3}{r_c^{\gamma-1}} = \frac{T_1 p_3}{r_c p_1 \times r_c^{\gamma-1}} = \frac{T_1 p_3}{r_c^\gamma p_1}$$

$$W = Q_1 - Q_2$$

$$= C_v (T_3 - T_2) - C_v (T_4 - T_1)$$

$$\therefore p_m (V_1 - V_2) = W$$

$$\therefore p_m = \frac{C_v [(T_3 - T_2)(T_4 - T_1)]}{V_1 - V_2}$$

$$= \frac{C_v \left[\frac{T_1 p_3}{r_c^\gamma p_1} - T_1 r_c^{\gamma-1} - \frac{T_1 p_3}{r_c^\gamma p_1} + T_1 \right]}{V_1 - \frac{V_1}{r_c}}$$

$$= \frac{C_v T_1 \left[p_3 - p_1 r_c^\gamma - \frac{p_3}{r_c^{\gamma-1}} + p_1 r_c \right]}{V_1 p_1 (r_c - 1)}$$

$$\left[\begin{array}{l} C_v \frac{R}{\gamma-1} \\ \therefore p_1 V_1 = RT_1 \end{array} \right]$$

$$= \frac{RT_1}{V_1 p_1} \left[(p_3 - p_1 r_c^\gamma) - \frac{p_3}{r_c^{\gamma-1}} + (p_3 - p_1 r_c^\gamma) \right]$$

$$= \frac{(p_3 - p_1 r_c^\gamma) \left(1 - \frac{1}{r_c^{\gamma-1}} \right)}{(\gamma-1)(r_c - 1)}$$

13.(B) $\frac{V_o}{V_i} = -\frac{R_F}{R_i}$

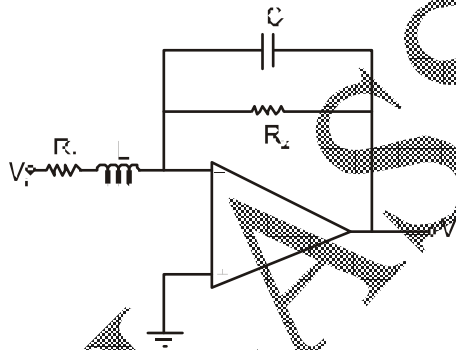

$$R_F = R_2 \parallel \frac{1}{sC} = \frac{R_2}{R_2 Cs + 1}$$

$$R'_1 = R_1 + sL$$

$$\frac{V_o}{V_i} = \frac{K}{(R_1 + sL)(R_2 Cs + 1)}$$

$$= \frac{K}{\left(1 + j \frac{f}{f_H} \right) \left(1 + j \frac{f}{f''_H} \right)} = \text{low pass filter}$$

14.(D) According to drude- Lorentz theory of free electrons, A metal is supposed to consist of positive metal ions fixed in the lattice, whose valence electrons move freely within the boundaries of the metal like gas molecules in a vessel. They applied the maxwell and Boltzmann statistics to the electron gas. which does not follow the pauli's exclusion principle.

15.(D) In laser beam stimulated emission occurs when photon is incident on an atom in excited state (metastable state).

16.(A) According to wein's displacement law maximum

$$\text{Wavelength } \lambda_m = \frac{b}{T}$$

$$\lambda'_m = \frac{b}{T'} = \frac{2b}{T}$$

$$\lambda'_m = 2\lambda_m$$

So, maximum wavelength of radiation becomes 2 times.

17.(B) The phenomena like interference, diffraction and polarization of light could be explained satisfactorily by considering that radiation is of electromagnetic nature i.e. radiation is of particle nature. It means radiations sometimes behaves as a wave and some times as a particle i.e radiation has dual nature.

So, the concepts of a "Particle" and a "wave" can both be applied to electromagnetic radiations.

18.(C)

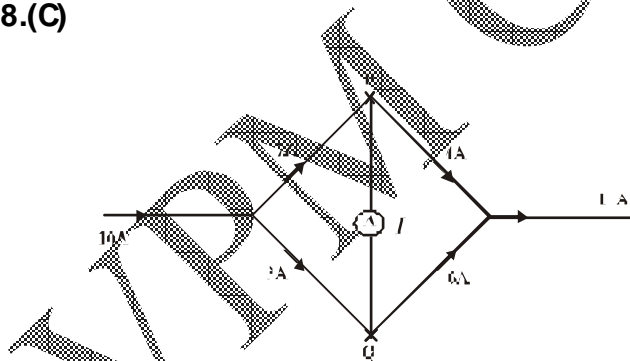

$$7 = 4 + I$$

⇒

$$I = 3A$$

- 19.(C)** According to Heisenberg's uncertainty principle "product of position and momentum of the particle is approximately equal to a number of the order \hbar and this product can never be smaller than the number of order $\frac{\hbar}{2}$."

$$\text{So, } \Delta x \cdot \Delta p_x \geq \frac{\hbar}{4\pi}$$

$$\boxed{\Delta x \cdot \Delta p_x \geq \frac{\hbar}{4\pi}}$$

- 20.(A)** The resistivity of conductor depends on the temperature as $\rho = \rho_0 (1 + \alpha T)$

So, as temperature decreases then resistivity also decreases.

- 21.(C)** The energy levels of linear harmonic oscillator are given by:

$$E_n = \left(n + \frac{1}{2}\right) \hbar\omega = \left(n + \frac{1}{2}\right) h\nu, \text{ where } n = 0, 1, 2, 3, \dots$$

For ground state $n = 0$, for first excited state $n = 1$,

For second excited state $n = 2$ and for third excited state $n = 3$.

$$\therefore \text{The energy of third excited state } E_3 = \left(3 + \frac{1}{2}\right) h\nu$$

$$\Rightarrow E_3 = \frac{7}{2} h\nu$$

$$\text{Given } E_3 = 0.1 \text{ eV} = 0.1 \times 1.6 \times 10^{-19} \text{ J} = 1.6 \times 10^{-20} \text{ J}$$

$$\therefore 1.6 \times 10^{-20} = \frac{7}{2} \times 6.62 \times 10^{-34} \text{ J} \times \nu$$

$$\Rightarrow \text{Frequency } \nu = \frac{2}{7} \times \frac{1.6 \times 10^{-20}}{6.62 \times 10^{-34}} = 3.304 \times 10^{13} \text{ hertz}$$

22.(B) The given matrix A possesses a minor of order 3

$$\begin{vmatrix} 1 & 3 & 1 \\ 2 & 4 & 0 \\ 3 & 1 & 5 \end{vmatrix} = \begin{vmatrix} 0 & 0 & 1 \\ 2 & 4 & 0 \\ -2 & -14 & 5 \end{vmatrix}, \text{ replacing } C_1 \text{ and } C_2 \text{ by } C_1 - C_3 \text{ and } C_2 - 3C_3.$$

$$= \begin{vmatrix} 2 & 4 \\ -2 & -14 \end{vmatrix}, \text{ expanding with respect to } R_1$$

$$= 2(-14) - (4)(-2) = -28 + 8 \neq 0$$

$$\therefore p(A) \geq 3$$

Also A does not possess any minor of order 4 i.e. $3+1$,

$$\text{so, } p(A) \leq 3$$

From equation (i) and (ii), we get $p(A) = 3$ i.e. the rank of A is 3.

23.(C) Conditional probability

$$P\left(\frac{A}{B}\right) = \frac{P(A \cap B)}{P(B)}$$

$$P(x+y=2) = \frac{1}{2} \times \frac{1}{4} + \frac{1}{4} \times \frac{1}{4} + \frac{1}{4} \times \frac{1}{2} = \frac{5}{6}$$

$$\text{Since condition: } x=0, \quad y=2$$

$$x=1, \quad y=1$$

$$x=2, \quad y=0$$

$$P(x-y=0) = \frac{1}{2} \times \frac{1}{2} + \frac{1}{4} \times \frac{1}{4} + \frac{1}{4} \times \frac{1}{4} = \frac{6}{16} \quad (\text{corr.})$$

$$\text{Since condition: } x=0, \quad y=0$$

$$x=1, \quad y=1$$

$$x=2, \quad y=2$$

$$P[(x + y = 2)/(x - y = 0)] = \frac{\frac{5}{16} - \frac{6}{16}}{\frac{6}{16}} = \frac{-1}{6}$$

But probability should not be negative, so answer is $\frac{1}{6}$

24.(D) $e^P = L^{-1} [(sI - P)^{-1}]$

and $P = \begin{bmatrix} s & 1 \\ 2 & s+3 \end{bmatrix}$

where $(sI - P)^{-1} = \begin{bmatrix} s & 1 \\ 2 & s+3 \end{bmatrix}^{-1}$

$$= \frac{1}{(s+1)(s+2)} \begin{bmatrix} s+3 & 1 \\ -2 & s \end{bmatrix}$$

$$= \begin{bmatrix} \frac{s+3}{(s+1)(s+2)} & \frac{1}{(s+1)(s+2)} \\ \frac{-2}{(s+1)(s+2)} & \frac{s}{(s+1)(s+2)} \end{bmatrix}$$

$$\therefore e^P = L^{-1} \begin{bmatrix} \frac{2}{s+1} & \frac{1}{s+2} & \frac{1}{s+1} & \frac{1}{s+2} \\ \frac{-2}{s+1} & \frac{2}{s+2} & \frac{2}{s+2} & \frac{1}{s+1} \end{bmatrix}$$

$$= \begin{bmatrix} 2e^{-1} - e^{-2} & e^{-1} - e^{-2} \\ -2e^{-1} + 2e^{-2} & 2e^{-2} - e^{-1} \end{bmatrix}$$

25.(A) $\vec{v} = \vec{w} \times \vec{r}$

$$\nabla \cdot \vec{v} = \nabla \cdot (\vec{w} \times \vec{r}) = -\vec{w} \cdot (\nabla \times \vec{r}) = 0$$

$\Rightarrow \vec{v}$ is solenoidal

26.(B) Given rest mass energy $E_R = m_0 c^2 = 0.51 \text{ Mev}$

And kinetic energy $T = 9.69 \text{ meV}$.

We know from Einstein theory

$$E = mc^2 = \text{K.E.} + \text{rest mass energy}$$

$$mc^2 = T + m_0c^2$$

$$\frac{mc^2}{m_0c^2} = \frac{T}{m_0c^2} + 1$$

$$\frac{m}{m_0} = 1 + \frac{T}{m_0c^2} = 1 + \frac{9.69}{0.51}$$

$$\frac{m}{m_0} = 1 + 19 = 20$$

$$m : m_0 = 20 : 1$$

27.(D) Voltage at inverting terminal $V_X = 1 \text{ V}$ (as noninverting terminal is at 1 V)

$$V_P = 2 \text{ volt}$$

At node X:

$$\frac{0 - V_X}{2} = \frac{V_X - V_Y}{2} + \frac{V_X - V_P}{1}$$

$$\frac{0 - 1}{2} = \frac{1 - V_Y}{2} + \frac{1 - 2}{1}$$

$$-\frac{1}{2} = \frac{1 - V_Y}{2} - 1$$

$$-1 = 1 - V_Y - 2 \quad \dots(1)$$

$$V_Y = 0$$

$$\text{At node P: } \frac{V_Y - V_P}{2} + \frac{V_X - V_P}{1} = \frac{V_P - V_Q}{1}$$

$$\frac{0 - 2}{2} + \frac{1 - 2}{1} = \frac{V - V_Q}{1}$$

$$-1 - 1 = 2 - V_0$$

or $V_0 = 4 \text{ volt.}$

28.(A) Volume of 100 gm of water at the beginning of stroke

$$= 104 \text{ c.c}$$

$$\therefore \text{ Specific volume } V_1 = \frac{104}{100} = 1.04 \text{ c.c./gm.}$$

Similarly specific volume of steam after isothermal change

$$V_2 = \frac{167404}{100} = 1674.04 \text{ c.c./gm.}$$

$$\therefore V_2 - V_1 = 1674.04 - 1.04 = 1673 \text{ c.c.}$$

Change in pressure

$$dP = 781 - 733.7 = 54.3 \text{ mm.} = 5.43 \text{ cm. of Hg}$$

$$= 5.43 \times 13.6 \times 981 \text{ dynes cm}^{-2}$$

$$\text{Mean temperature } T = \frac{101 + 99}{2} = 100^\circ\text{C} = 373 \text{ K}$$

and $dT = 101 - 99 = 2^\circ.$

Now according to Clapeyron's latent heat equation

$$\frac{dP}{dT} = \frac{L}{T(V_2 - V_1)}$$

$$L = \frac{T(V_2 - V_1) \times dP}{dT}$$

$$= \frac{373 \times 1673 \times 5.43 \times 13.6 \times 981}{2} \text{ ergs.}$$

$$= \frac{373 \times 1673 \times 5.43 \times 13.6 \times 981}{2 \times 4.2 \times 10^7} \text{ cal./gm.}$$

$$= 540.0 \text{ cal./gm.}$$

29.(B) Let us take one by one. Using values of charge Q, baryon number B and strangeness number S, we have

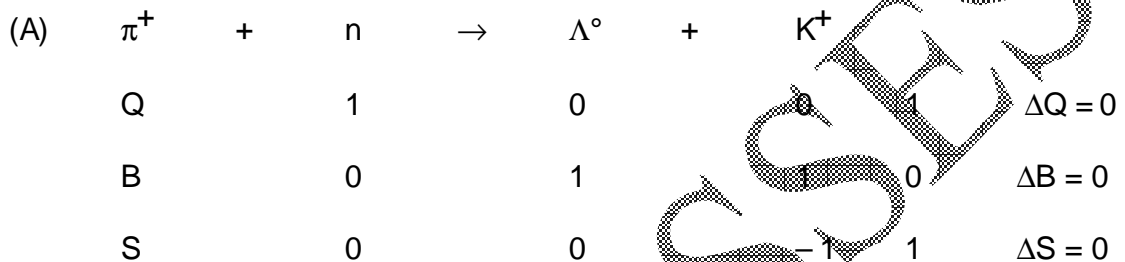

Here, reaction (A) is allowed under these conservation laws.

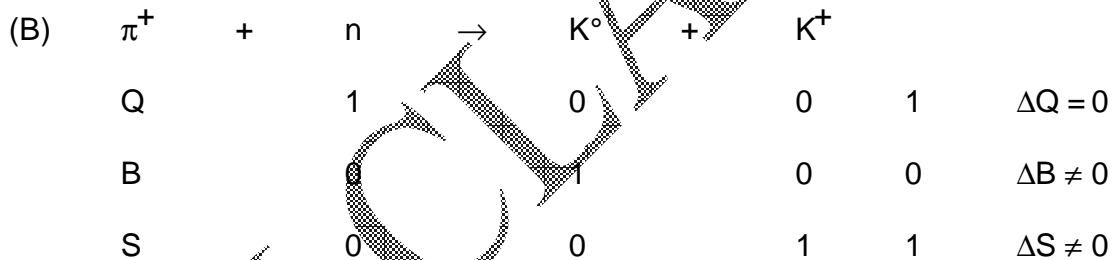

So reaction (B) is forbidden under these conservation laws.

Here this reaction is not allowed by baryon number and strangeness number.

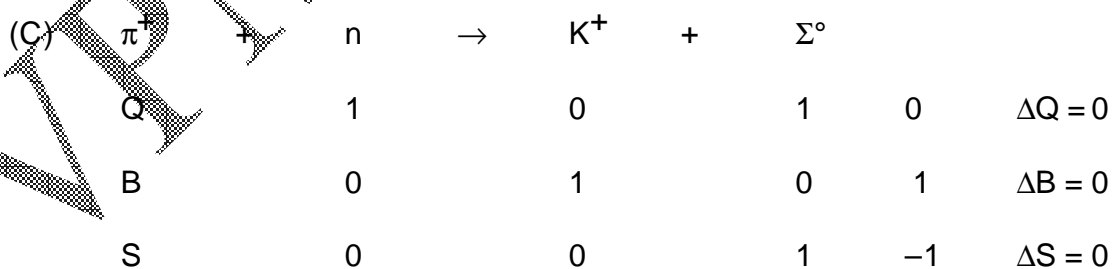

Hence reaction (C) is allowed under these conservation Laws.

(D)	Δ°	\rightarrow	Σ^{+}	+	π^{-}		
	Q		0		1	-1	$\Delta Q = 0$
	B		1		1	0	$\Delta B = 0$
	S		-1		-1	0	$\Delta S = 0$

Hence reaction (D) is allowed under these conservation laws.

- 30.(C)** The torque due to gravity is the only external torque acting about the pivot of the swing. This torque is zero at B and

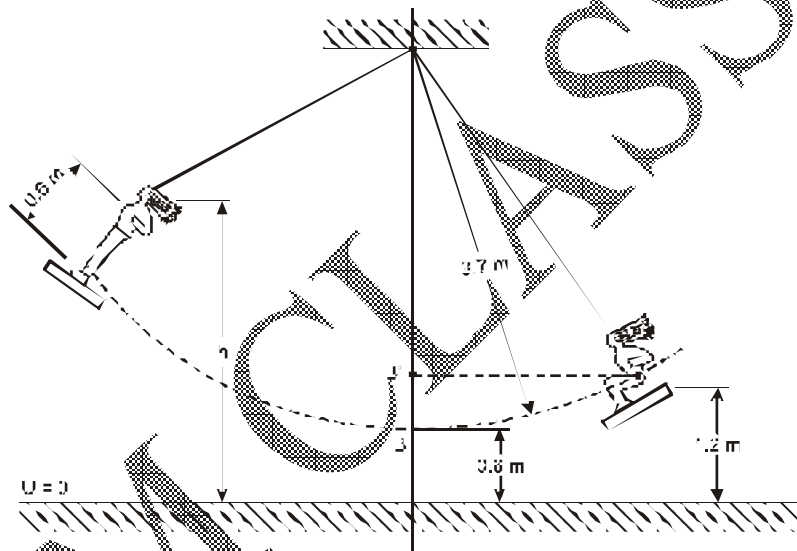

remains zero for the instant during which the girl stands up. The angular momentum is conserved at B.

Considering the girl-swing system to be a rigid body just before and after she stands up, we have $I\omega = I'\omega'$. Letting $R = 3.7$ m and $R' = 3.1$ m be the distances from the pivot to the CM of the girl before and after, we have $I = mR^2 + I_{CM}$, $I' = mR'^2 + I'_{CM}$, where I_{CM} and I'_{CM} are the moments of inertia of the girl about her CM before and after. Since R, R' are large compared with the dimensions of the

girl, we have $I_{CM} \ll mR^2$ and $I'_{CM} \ll mR'^2$. Then approximately $mR^2\omega = mR'^2\omega'$ or $mRv_B = mR'v'_B$, where v_B, v'_B are CM speeds. Thus $3.7mv_B = 3.1m v'_B$, or $v'_B = 1.2v_B$. From the conservation of energy, $\frac{1}{2}mv_B^2 = mg(1.2 - 0.6)$, or $v_B = 3.43$ m/s. Then $v'_B = 1.2v_B = 4.1$ m/s

Again we can use the conservation principle to write

$$\frac{1}{2}mv_B'^2 = mg(h - 1.2)$$

or
$$h = \frac{v_B'^2}{2g} + 1.2 = \frac{(4.1)^2}{2 \times 10} + 1.2 = 2.04$$
 m

- 31.(D)** Darkness is observed when the light beams from the two legs are 180° out of phase. As the length of one leg is increased by $\frac{1}{2}\lambda$, the path length (down and back) increases by λ and the field of view changes from dark to bright to dark. When 150 fringes pass, the leg is lengthened by an amount.

$$(150) \left(\frac{1}{2}\lambda \right) = (150)(240 \text{ nm})$$

$$= 36000 \text{ nm} = 0.036 \text{ mm}$$

- 32.(C)** Only the 1.0-m sides have induced voltages. Let the side at $y = 0.50$ m be 1.

$$v_1 = B_1 \ell U = 0.80e^{-0.25}(1)(250) = 155.8 \text{ V} \quad v_2 = B_2 \ell U = 148.2 \text{ V}$$

The voltage are the polarity shown. The instantaneous current is

$$I = \frac{155.8 - 148.2}{2.5} = 3.04 \text{ A}$$

- 33.(D)** The present state of the electron is $|+\frac{1}{2}\rangle$; the spin operation component along z is

$$S_{z'} = \mathbf{S} \cdot \mathbf{n} = \frac{\hbar}{2} \boldsymbol{\sigma} \cdot \mathbf{n}$$

where \mathbf{n} is a unit vector along z' . In our case, $\mathbf{n} = \hat{x} \sin \theta \cos \phi + \hat{y} \sin \theta \sin \phi + \hat{z} \cos \theta$ and therefore,

$$S_{z'} = S_x \sin \theta \cos \phi + S_y \sin \theta \sin \phi + S_z \cos \theta \quad \dots(2)$$

The eigenvalues of $S_{z'}$ are $+\hbar/2$ or $-\hbar/2$, and the eigenvectors of $S_{z'}$ with the basis eigenvectors of S_z are

$$|+\frac{1}{2}\rangle' = a|+\frac{1}{2}\rangle + b|-\frac{1}{2}\rangle \quad \dots(3)$$

$$S_{z'}|+\frac{1}{2}\rangle' = +\frac{\hbar}{2}|+\frac{1}{2}\rangle \quad \dots(4)$$

and

$$|-\frac{1}{2}\rangle' = c|+\frac{1}{2}\rangle + d|-\frac{1}{2}\rangle \quad \dots(5)$$

$$S_{z'}|-\frac{1}{2}\rangle' = -\frac{\hbar}{2}|-\frac{1}{2}\rangle \quad \dots(6)$$

where $a, b, c,$ and d are complex constants. By substituting (2) and (3) into (4) we obtain

$$(S_x \sin \theta \cos \phi + S_y \sin \theta \sin \phi + S_z \cos \theta) \left(a|+\frac{1}{2}\rangle + b|-\frac{1}{2}\rangle \right) = \frac{\hbar}{2} \left(a|+\frac{1}{2}\rangle + b|-\frac{1}{2}\rangle \right) \quad \dots(7)$$

Using the known relations

$$\begin{cases} S_x |+\frac{1}{2}\rangle = \frac{\hbar}{2} |-\frac{1}{2}\rangle \\ S_y |+\frac{1}{2}\rangle = \frac{i\hbar}{2} |-\frac{1}{2}\rangle \\ S_z |+\frac{1}{2}\rangle = \frac{\hbar}{2} |+\frac{1}{2}\rangle \end{cases} \quad \begin{cases} S_x |-\frac{1}{2}\rangle = \frac{\hbar}{2} |+\frac{1}{2}\rangle \\ S_y |-\frac{1}{2}\rangle = \frac{i\hbar}{2} |+\frac{1}{2}\rangle \\ S_z |-\frac{1}{2}\rangle = \frac{\hbar}{2} |-\frac{1}{2}\rangle \end{cases} \quad \dots(8)$$

so (7) turns into the form

$$\frac{\hbar a}{2} \left\{ \sin \theta \cos \phi \left| -\frac{1}{2} \right\rangle + i \sin \theta \sin \phi \left| -\frac{1}{2} \right\rangle + \cos \theta \left| +\frac{1}{2} \right\rangle \right\} + \frac{\hbar b}{2} \left\{ \sin \theta \cos \phi \left| +\frac{1}{2} \right\rangle - i \sin \theta \sin \phi \left| +\frac{1}{2} \right\rangle - \cos \theta \left| -\frac{1}{2} \right\rangle \right\}$$

$$= \frac{\hbar}{a} \left(a \left| +\frac{1}{2} \right\rangle + b \left| -\frac{1}{2} \right\rangle \right) \quad \dots(9)$$

Hence, we obtain

$$\begin{cases} a \sin \theta \cos \phi + i a \sin \theta \sin \phi - b \cos \theta = b \\ a \cos \theta + b \sin \theta \cos \phi - i b \sin \theta \sin \phi = a \end{cases} \quad \dots(10)$$

or $a = \frac{(1 + \cos \theta)b}{\sin \theta (\cos \phi + i \sin \phi)} \cdot \left| +\frac{1}{2} \right\rangle$ must be a unit vector, thus, $|a|^2 + |b|^2 = 1$ and

$$|b|^2 \left(1 + \frac{(1 + \cos \theta)^2}{\sin^2 \theta} \right) = 1, \text{ so}$$

$$|b|^2 = \frac{\sin^2 \theta}{2 + 2 \cos \theta} = \frac{\sin^2 \theta}{4 \cos^2 \left(\frac{\theta}{2} \right)} = \frac{4 \sin^2 \left(\frac{\theta}{2} \right) \cos^2 \left(\frac{\theta}{2} \right)}{4 \cos^2 \left(\frac{\theta}{2} \right)} = \sin^2 \left(\frac{\theta}{2} \right) \quad \dots(11)$$

We choose $b = e^{i\phi} \sin \left(\frac{\theta}{2} \right)$; hence

$$a = \frac{(1 + \cos \theta) \sin \left(\frac{\theta}{2} \right) e^{i\phi}}{\sin \theta} = \frac{2 \cos^2 \left(\frac{\theta}{2} \right) \sin \left(\frac{\theta}{2} \right) e^{i\phi}}{\sin \theta} = \cos \left(\frac{\theta}{2} \right) e^{i\phi} \quad \dots(12)$$

so we obtain

$$\left| +\frac{1}{2} \right\rangle \tilde{n} = \cos \left(\frac{\theta}{2} \right) \left| +\frac{1}{2} \right\rangle + \sin \left(\frac{\theta}{2} \right) e^{i\phi} \left| -\frac{1}{2} \right\rangle \quad \dots(13)$$

The average value of the spin along z' is $\langle S_z \rangle = \langle + | S_z | + \rangle$. Using the relation

$$S_z \left| +\frac{1}{2} \right\rangle \tilde{n} = S_z \left(\cos \left(\frac{\theta}{2} \right) \left| +\frac{1}{2} \right\rangle + \sin \left(\frac{\theta}{2} \right) e^{-i\phi} \left| -\frac{1}{2} \right\rangle \right) = \frac{\hbar}{2} \left(\cos \left(\frac{\theta}{2} \right) \left| +\frac{1}{2} \right\rangle - \sin \left(\frac{\theta}{2} \right) e^{-i\phi} \left| -\frac{1}{2} \right\rangle \right)$$

...(14)

we obtain

$$\begin{aligned}
 \langle S_z \rangle &= \langle +\frac{1}{2} | S_z | +\frac{1}{2} \rangle = \langle +\frac{1}{2} | \frac{\hbar}{2} \left(\cos\left(\frac{\theta}{2}\right) | +\frac{1}{2} \rangle - \sin\left(\frac{\theta}{2}\right) e^{-i\phi} | -\frac{1}{2} \rangle \right) \\
 &= \frac{\hbar}{2} \left[\cos\left(\frac{\theta}{2}\right) \langle +\frac{1}{2} | +\frac{1}{2} \rangle - \sin\left(\frac{\theta}{2}\right) e^{-i\phi} \langle +\frac{1}{2} | -\frac{1}{2} \rangle \right] \\
 &= \frac{\hbar}{2} \left[\cos\left(\frac{\theta}{2}\right) \cos\left(\frac{\theta}{2}\right) - \sin\left(\frac{\theta}{2}\right) e^{i\phi} \sin\left(\frac{\theta}{2}\right) e^{-i\phi} \right] \\
 &= \frac{\hbar}{2} \left[\cos^2\left(\frac{\theta}{2}\right) - \sin^2\left(\frac{\theta}{2}\right) \right] = \frac{\hbar \cos\theta}{2}
 \end{aligned}$$

34.(B) The field strength at a distance r from an infinite linear charge of density λ is given by

$$E = \frac{1}{4\pi\epsilon_0} \frac{2\lambda}{r}$$

By definition electric potential at a distance r from the axis is

$$\phi = - \int_{r_{ref}}^r E \cdot dr$$

Hence r_{ref} denotes the reference distance for zero potential. Here reference distance can not be taken as infinity since the wire itself extends to infinity.

In this case we have to find the potential difference between two points distant r_1 and r_2 from the wire, which is given by

$$\therefore \Delta\phi = - \int_{r_2}^{r_1} \frac{1}{4\pi\epsilon_0} \frac{2\lambda}{r} dr = \frac{1}{4\pi\epsilon_0} \cdot 2\lambda \log_e \frac{r_2}{r_1}$$

35.(A) Cover the closed surface by small adjacent rectangles, whose circumference is formed by four lines L_i each, then Stokes theorem gives,

$$\int_s (\nabla \times A) \cdot d\sigma = \sum_{s_i} \int (\nabla \times A) \cdot d\sigma = \sum \int A \cdot dl = 0$$

36.(B)

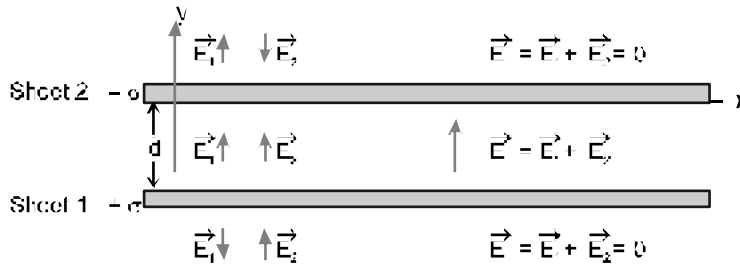

Let sheet 1 be the lower sheet of positive charge, and let sheet 2 be the upper sheet of negative charge; the fields due to each sheet are \vec{E}_1 and \vec{E}_2 , respectively, both \vec{E}_1 and \vec{E}_2 have the same magnitude at all points, no matter how far from either sheet:

$$E_1 = E_2 = \frac{\sigma}{2\epsilon_0}$$

At all points, the direction \vec{E}_1 is away from the positive charge of sheet 1, and the direction of \vec{E}_2 is toward the negative charge of sheet 2. These fields, as well as the x - and y -axes, are shown in Fig.

At point between the sheets, \vec{E}_1 and \vec{E}_2 ; at points above the upper sheet or below the lower sheet, \vec{E}_1 and \vec{E}_2 cancel each other. Thus the total field is

$$\vec{E} = \vec{E}_1 + \vec{E}_2 = \begin{cases} 0 & \text{above the upper sheet} \\ \frac{\sigma}{\epsilon_0} \hat{j} & \text{between the sheets} \\ 0 & \text{below the lower sheet} \end{cases}$$

37.(B) Given $[A, B^n] = n[A, B]B^{n-1}$ (1)

and we know A, B also satisfying the following Commutator property

$$\begin{aligned} [A, B^{n+1}] &= [A, B^n B] = [A, B]B^n + n[A, B]B^n \\ &= (n+1)[A, B]B^n \end{aligned} \quad \text{....(2)}$$

$F(x)$ is analytic function so the expansion of $F(x)$ in a power series, $F(x) = \sum_n a_n x^n$

$$\text{So, } F(B) = \sum_n a_n B^n$$

$$\text{So, } [A, F(B)] = \left[A, \sum_n a_n B^n \right] = \sum_n a_n [A, B^n] = \sum_n a_n n [A, B] B^{n-1} \text{ from eq (2)}$$

$$[A, F(B)] = [A, B] \sum_n n a_n B^{n-1} \quad \dots (3)$$

$$\text{We know } F(B) = \sum_n a_n B^n$$

$$F'(B) = \sum_n n a_n B^{n-1}$$

So, from eq. (3)

$$[A, F(B)] = [A, B] F'(B)$$

38.(C) To obtain the matrix representation of S^2 , we use the matrices of S_x , S_y and S_z in the basis of eigen vectors of S_z .

$$S_x = \frac{\hbar}{2} \begin{bmatrix} 0 & 1 \\ 1 & 0 \end{bmatrix} \quad S_y = \frac{\hbar}{2} \begin{bmatrix} 0 & -i \\ i & 0 \end{bmatrix} \quad S_z = \frac{\hbar}{2} \begin{bmatrix} 1 & 0 \\ 0 & -1 \end{bmatrix}$$

$$\text{Here } S^2 = S_x^2 + S_y^2 + S_z^2 = \left[\frac{\hbar}{2} \right]^2 [\sigma_x^2 + \sigma_y^2 + \sigma_z^2]$$

for pauli spin matrix

$$\therefore \sigma_x^2 + \sigma_y^2 + \sigma_z^2 = 1 + 1 + 1 = 3I$$

$$\text{So, } S^2 = 3 \left[\frac{\hbar}{2} \right]^2 I = \frac{3\hbar^2}{4} \begin{bmatrix} 1 & 0 \\ 0 & 1 \end{bmatrix}$$

39.(D) $f = n (\phi_1 + 2i \phi_2)$

Given ϕ_1 and ϕ_2 be orthonormal functions So, satisfying the following conditions –

$$\langle \phi_1 | \phi_1 \rangle = 1 = \langle \phi_2 | \phi_2 \rangle$$

$$\langle \phi_1 | \phi_2 \rangle = 0 = \langle \phi_2 | \phi_1 \rangle$$

\therefore Given f is normalized so, $\langle f | f \rangle = 1$

$$\text{So, } 1 = n^2 \langle \phi_1 + 2i\phi_2 | \phi_1 - 2i\phi_2 \rangle$$

$$1 = n^2 [\langle \phi_1 | \phi_1 \rangle + 4\langle \phi_2 | \phi_2 \rangle - 2i\langle \phi_1 | \phi_2 \rangle + 2i\langle \phi_2 | \phi_1 \rangle]$$

$$1 = n^2 [1 + 4 - 0 + 0]$$

$$n^2 = \frac{1}{5}$$

$$\boxed{n = \frac{1}{\sqrt{5}}}$$

40.(A) $f(z) = \frac{z}{\cos z}$ has pole at $z = (2n+1)\frac{\pi}{2}$

where $n = 0, 1, 2, \dots$

$$\Rightarrow \text{residue of } f(z) \text{ at } z = (2n+1)\frac{\pi}{2}$$

41.(B) On the basis of spin number elementary particles are divided into two broad categories as –

1. Boson (spin $s \rightarrow$ whole integers $s = 0, 1, 2$)

2. fermions (spin $s \rightarrow$ half integers $s = \pm \frac{1}{2} + \frac{3}{2}, \dots$)

42.(D) Since $a = a^{-1} \quad \forall a \in G$

$$\therefore b = b^{-1} \quad \forall b \in G$$

$$\text{Also, } (ab)^{-1} = ab \quad [\because a, b \in G \Rightarrow ab \in G]$$

$$\Rightarrow b^{-1} a^{-1} = ab \Rightarrow ba = ab \quad \forall a, b \in G$$

$\therefore G$ is abelian,

43.(B) If X-axis is taken vertically, Z-axis towards north and Y-axis along east, then the velocity of the bullet is $v=500$ km/sec and angular velocity $\omega = \omega (\hat{k} \cos 30^\circ + \hat{i} \sin 30^\circ)$, because the angular velocity vector ω of the earth is directed parallel to its axis and is inclined at 30° to the horizontal.

$$\text{Here, } \omega = \frac{2\pi}{24 \times 60 \times 60} = 7.2 \times 10^{-5} \text{ rad./sec.}$$

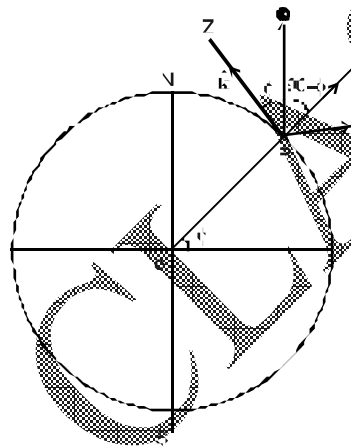

Fig.

Hence Coriolis acceleration

$$\begin{aligned} &= 2 \omega \times v = 2 \omega (\hat{k} \cos 30^\circ + \hat{i} \sin 30^\circ) \times 500 \hat{k} \\ &= -2 \times 7.2 \times 10^{-5} \times 500 \times \frac{1}{2} \hat{j} = 0.036 \text{ m/sec}^2 \text{ towards west.} \end{aligned}$$

44.(B) The given matrix A possesses a minor of order 3

$$\begin{vmatrix} 1 & 3 & 1 \\ 2 & 4 & 0 \\ 3 & 1 & 5 \end{vmatrix} = \begin{vmatrix} 0 & 0 & 1 \\ 2 & 4 & 0 \\ -2 & -14 & 5 \end{vmatrix}, \text{ replacing } C_1 \text{ and } C_2 \text{ by } C_1 - C_3 \text{ and } C_2 - 3C_3.$$

$$= \begin{vmatrix} 2 & 4 \\ -2 & -14 \end{vmatrix}, \text{ expanding with respect to } R_1$$

$$= 2(-14) - (4)(-2) = -28 + 8 \neq 0$$

$$\therefore p(A) \geq 3$$

Also A does not possess any minor of order 4 i.e., $3 + 1$,

$$\text{so, } p(A) \leq 3$$

From equation (i) and (ii), we get $p(A) = 3$ i.e., the rank of A is 3.

45.(B) Here $a = 0, b = 6, n = 6, h = \frac{b-a}{n} = \frac{6-0}{6} = 1$

x	0	1	2	3	4	5	6
$y = \frac{1}{1+x^2}$	1.000 (y_0)	0.5 (y_1)	0.2 (y_2)	0.1 (y_3)	0.0588 (y_4)	0.0385 (y_5)	0.027 (y_6)

By Simpson's $\frac{1}{3}$ rule—

$$\text{Hence } \int_0^6 \frac{1}{1+x^2} dx = \frac{h}{3} [(y_0 + y_6) + 4(y_1 + y_3 + y_5) + 2(y_2 + y_4)] = \frac{1}{3}$$

$$[(1+0.027) + 4(0.5+0.1+0.0385) + 2(0.2+0.0588)] = \frac{1}{3} [1.027 + 2.554 + 0.5176] =$$

$$\frac{4.0986}{3} = 1.3662$$

46.(A)

$$D_n = \begin{bmatrix} 1 & 0 & 1 & 0 & \dots & 0 \\ 0 & 1 & 1 & 1 & \dots & 0 \\ 0 & 0 & 1 & 1 & 1 & \dots & 0 \\ \dots & \dots & \dots & \dots & \dots & \dots & \dots \\ \dots & \dots & \dots & \dots & \dots & \dots & \dots \\ 0 & 0 & 0 & \dots & 1 & 1 & 1 \\ 0 & 0 & 0 & \dots & 0 & 1 & 1 \end{bmatrix} \text{ of order } n$$

$$= \begin{bmatrix} 0 & 1 & 0 & \dots & 0 \\ 1 & 1 & 1 & \dots & 0 \\ 0 & 1 & 1 & 1 & \dots & 0 \\ 0 & 0 & 1 & 1 & 1 & \dots & 0 \\ \dots & \dots & \dots & \dots & \dots & \dots & \dots \\ 0 & 0 & 0 & \dots & 1 & 1 & 1 \\ 0 & 0 & 0 & \dots & 0 & 1 & 1 \end{bmatrix} \text{ of order } (n - 1) \text{ expanding in terms of } R_1.$$

$$= (-1) \begin{bmatrix} 1 & 1 & 0 & \dots & 0 \\ 0 & 1 & 1 & 0 & \dots & 0 \\ 0 & 1 & 1 & 1 & \dots & 0 \\ 0 & 0 & 0 & \dots & 1 & 1 & 1 \\ 0 & 0 & 0 & \dots & 0 & 1 & 1 \end{bmatrix} \text{ of order } (n - 2)$$

$$= (-1)^2 \begin{bmatrix} 1 & 0 & 0 & \dots & 0 \\ 1 & 1 & 1 & 0 & \dots & 0 \\ 0 & 1 & 1 & 1 & 0 & \dots & 0 \\ 0 & 0 & 1 & 1 & 1 & \dots & 0 \\ \dots & \dots & \dots & \dots & \dots & \dots & \dots \\ 0 & 0 & 0 & \dots & 0 & 1 & 1 & 1 \\ 0 & 0 & 0 & \dots & 0 & 0 & 1 & 1 \end{bmatrix} \text{ of order } (n - 3)$$

Therefore, $D_{3k} = (-1) D_3 (k-1)$
 $= (-1)^2 D_3 (k-2) \dots$
 $= (-1)^{k-1} D_3$

$$D_3 = \begin{bmatrix} 1 & 1 & 0 \\ 1 & 1 & 1 \\ 0 & 1 & 1 \end{bmatrix} = -1$$

Therefore, $D_{3k} = (-1)^{k-1} (-1) = (-1)^k$

47.(A) We know that $R = (2/a_0^{3/2})E^{-r/a_0}$. Hence

$$\frac{dR}{dr} = \left(\frac{2}{a_0^{5/2}}\right)e^{-r/a_0}$$

and $\frac{1}{r^2} \frac{d}{dr} \left(r^2 \frac{dR}{dr} \right) = \left(\frac{2}{a_0^{7/2}} - \frac{4}{a_0^{5/2}r} \right) e^{-r/a_0}$

We know radial equation for H-atom is

$$\frac{1}{r^2} \frac{d}{dr} \left(r^2 \frac{dR}{dr} \right) + \left[\frac{2m}{\hbar^2} \left(\frac{e^2}{4\pi\epsilon_0 r} + E \right) - \frac{\ell(\ell+1)}{r^2} \right] \times R = 0 \quad \dots(1)$$

Substituting in Eq.(1) with $E = E_1$ and $\ell = 0$ gives

$$\left[\left(\frac{2}{a_0^{7/2}} + \frac{4mE_1}{\hbar^2 a_0^{3/2}} \right) \left(\frac{me^2}{\pi\epsilon_0 \hbar a_0^{3/2}} - \frac{4}{a_0^{5/2}} \right) \frac{1}{r} \right] e^{-r/a_0} = 0$$

For the first parenthesis, $\frac{2}{a_0^{7/2}} + \frac{4mE_1}{\hbar^2 a_0^{3/2}} = 0$

$$E_1 = -\frac{\hbar^2}{2ma_0^2}$$

48.(D) Let the gas be a member of an ensemble, each member of which is in thermal and diffusive contact with a reservoir at temperature T and chemical potential μ then

$$Z(\mu, T) = \sum_{N_r=0}^{\infty} \left[\sum_{r=1}^{\infty} e^{\{(\mu N_r - U_r)/\beta\}} \right]$$

or
$$Z(\mu, T) = \sum_{N_r=0}^{\infty} e^{\beta\mu N_r} Z(T, N_r) \dots\dots\dots(1)$$

Where
$$Z(T, N_r) = \sum_{r=1}^{\infty} e^{-\beta U_r} \dots\dots\dots(2)$$

is the partition function of gas, This summation is for a given value of N_r . So for a classical ideal gas,

$$Z(T, N_r) = \frac{1}{N_r!} [Z(T)]^{N_r} \dots\dots\dots(3)$$

Where $z(T)$ is the partition function of a single particle, Equation (1) now becomes

$$Z(\mu, T) = \sum_{N_r} \frac{1}{N_r!} [e^{\beta\mu} z(T)]^{N_r} \dots\dots\dots(4)$$

49.(A)
$$v = \frac{ds}{dt} \Rightarrow ds = v \cdot dt$$

$$\Rightarrow \int ds = \int v dt$$

$$s = \int_0^{20} v \cdot dt$$

The train starts from rest, \therefore the velocity $v = 0$ when $t = 0$.

The given table of velocities can be written as:

t	0	2	4	6	8	10	12	14	16	18	20
v	0	16	28.8	40	46.4	51.2	32	17.6	8	3.2	0
	y_0	y_1	y_2	y_3	y_4	y_5	y_6	y_7	y_8	y_9	y_{10}

$$h = \frac{2}{60} \text{hrs} = \frac{1}{30} \text{hrs.}$$

The Simpson's rule is

$$s = \int_0^{20} v \cdot dt = \frac{h}{3} [(y_0 + y_{10}) + 4(y_1 + y_3 + y_5 + y_7 + y_9) + 2(y_2 + y_4 + y_6 + y_8)]$$

$$= \frac{1}{30 \times 3} [(0+0) + 4(16+40+51.2+17.6+3.2) + 2(28.8+46.4+32.0+8)]$$

$$= \frac{1}{90} [0 + 4 \times 128 + 2 \times 115.2] = 8.25 \text{ km.}$$

Hence the distance run by the train in 20 minutes = 8.25 km.

50.(A) $P (2 \leq x \leq 3) = \int_2^3 f(x) dx = \int_2^3 \frac{3+2x}{18} dx = \frac{4}{9}$

51.(A) From boundary conditions,

$$D_{1n} = D_{2n} \text{ (normal component of disp. vector)}$$

$$E_{1t} = E_{2t} \text{ (tangential component of electric field)}$$

$$\therefore \left. \begin{array}{l} D_1 \cos \theta_1 = D_2 \cos \theta_2 \\ E_1 \sin \theta_1 = E_2 \sin \theta_2 \end{array} \right\} |D| = \epsilon |E|$$

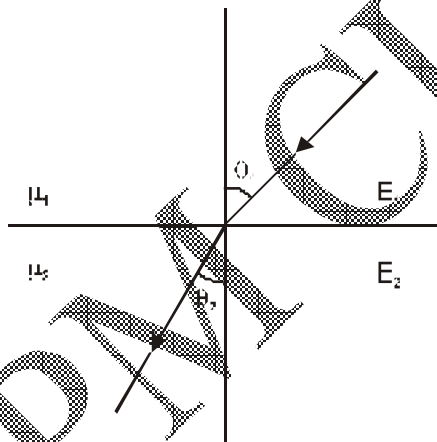

$$\Rightarrow \epsilon_1 \cot \theta_1 = \epsilon_2 \cot \theta_2,$$

$$\frac{\epsilon_1 \cot \theta_1}{\epsilon_2 \cot \theta_2} = 1$$

$$\Rightarrow \frac{\epsilon_1}{\epsilon_2} = \frac{\tan \theta_1}{\tan \theta_2}$$

52.(B) We know Recurrence relation

$$\frac{d}{dx} [x^n J_n(x)] = x^n J_{n-1}(x)$$

put $n = 1$

$$\frac{d}{dx} [x^1 J_1(x)] = x^1 J_0(x)$$

$$= x J_0(x)$$

53.(B) The given equation written in the standard form is

$$\frac{d^2 y}{dx^2} - \frac{2(x+3)}{x+1} \frac{dy}{dx} + \frac{x+5}{x+1} y = \frac{e^x}{x+1}$$

$$P = \frac{2(x+3)}{x+1}, \quad Q = \frac{x+5}{x+1}, \quad R = \frac{e^x}{x+1}$$

$$\text{We have } 1 + P + Q = \frac{x+1-2x-6+x+5}{x+1} = 0.$$

$\therefore y = e^x$ is a part of the C. F.

54.(A) In deuteron problem schrodinger equation will be written as-

$$\frac{d^2 U}{dr^2} + \frac{M}{\hbar^2} (V_0 - B) U = 0 \quad \text{for } r < b$$

$$\frac{d^2 U}{dr^2} + \frac{M}{\hbar^2} (-B) U = 0 \quad \text{for } r > b$$

$$\text{Let } k^2 = M(V_0 - B) / \hbar^2$$

$$k^2 = MB / \hbar^2$$

where $V_0 \rightarrow$ potential depth of square well

$B \rightarrow$ Binding energy

$$\text{So, } \frac{K^2}{\infty^2} = \frac{V_0 - B}{B}$$

$$\frac{K}{\infty} = \sqrt{\frac{V_0 - B}{B}}$$

$$\text{Given } b = \frac{\pi}{2K}$$

$$\text{So, } K = \frac{\pi}{2b}$$

$$\text{and } R = \frac{1}{\infty}$$

$$\text{So, } \frac{\pi}{2b} R = \sqrt{\frac{V_0 - B}{B}}$$

$$V_0 \gg B \quad \text{So, } V_0 - B \approx V_0$$

$$\text{So, } R = \frac{2b V_0^{1/2}}{\pi B^{1/2}}$$

55.(D) The boundary surface consists of two parts - a hemispherical "bowl" at radius R , and a circular disk at $\theta = \pi/2$.

For the bowl,

$$da = R^2 \sin \theta \, d\theta \, d\phi \, \hat{r} \quad \text{..(a)}$$

$$\text{and } E = \frac{1}{4\pi\epsilon_0} \frac{Q}{R^2} \hat{r} \quad \text{..(1)}$$

In cartesian components

$$\hat{r} = \sin \theta \cos \phi \, \hat{x} + \sin \theta \sin \phi \, \hat{y} + \cos \theta \, \hat{z} \quad \text{..(2)}$$

$$\text{So } T_{ZX} = \epsilon_0 E_z E_x$$

$$T_{zx} = \epsilon_0 \left(\frac{1}{4\pi\epsilon_0} \frac{Q}{R^2} \cos \theta \right) \left(\frac{1}{4\pi\epsilon_0} \frac{Q}{R^2} \sin \theta \cos \phi \right)$$

$$T_{zx} = \epsilon_0 \left(\frac{Q}{4\pi\epsilon_0 R^2} \right)^2 \sin \theta \cos \theta \cos \phi \quad \dots(3)$$

$$T_{zy} = \epsilon_0 E_z E_y = \epsilon_0 \left(\frac{Q}{4\pi\epsilon_0 R^2} \cos \theta \right) \left(\frac{Q}{4\pi\epsilon_0 R^2} \sin \theta \sin \phi \right)$$

$$T_{zy} = \epsilon_0 \left(\frac{Q}{4\pi\epsilon_0 R^2} \right)^2 \sin \theta \cos \theta \sin \phi \quad \dots(4)$$

$$T_{zz} = \frac{\epsilon_0}{2} (E_z^2 - E_x^2 - E_y^2)$$

$$= \frac{\epsilon_0}{2} \left(\frac{Q}{4\pi\epsilon_0 R^2} \right)^2 (\cos^2 \theta - \sin^2 \theta \cos^2 \phi - \sin^2 \theta \sin^2 \phi)$$

$$= \frac{\epsilon_0}{2} \left(\frac{Q}{4\pi\epsilon_0 R^2} \right)^2 (\cos^2 \theta - \sin^2 \theta) \quad \dots(5)$$

The net force is obviously in the z-direction

So it suffices to calculate

$$(\vec{T} \cdot d\vec{a}) = T_x da_x + T_y da_y + T_z da_z \quad \dots(6)$$

from eq. (1) and (2)

$$da_x = R^2 \sin \theta d\theta d\phi (\sin \theta \cos \phi) = R^2 \sin^2 \theta \cos \phi d\theta d\phi$$

$$da_y = R^2 \sin \theta d\theta d\phi (\sin \theta \sin \phi) = R^2 \sin^2 \theta \sin \phi d\theta d\phi$$

$$da_z = R^2 \sin \theta d\theta d\phi (\cos \theta) = R^2 \sin \theta \cos \theta d\theta d\phi$$

$$T_{zx} da_x = \epsilon_0 \left(\frac{Q}{4\pi\epsilon_0 R} \right)^2 \sin^3 \theta \cos \theta \cos^2 \phi d\theta d\phi$$

$$T_{zy} da_y = \epsilon_0 \left(\frac{Q}{4\pi\epsilon_0 R} \right)^2 \sin^3 \theta \cos \theta \sin^2 \phi d\theta d\phi$$

$$T_{zz} da_z = \frac{\epsilon_0}{2} \left(\frac{Q}{4\pi\epsilon_0 R} \right)^2 (\sin \theta \cos^3 \theta - \cos \theta \sin^3 \theta) d\theta d\phi$$

put these values in eq. (6)

$$(\vec{T} \cdot d\vec{a})_z = \frac{\epsilon_0}{2} \left(\frac{Q}{4\pi\epsilon_0 R} \right)^2 [2 \sin^3 \theta \cos \theta \cos^2 \phi + 2 \sin^3 \theta \cos \theta \sin^2 \phi + \sin \theta \cos^3 \theta \sin^3 \theta] d\theta d\phi$$

$$(\vec{T} \cdot d\vec{a})_z = \frac{\epsilon_0}{2} \left(\frac{Q}{4\pi\epsilon_0 R} \right)^2 \sin \theta \cos \theta d\theta d\phi$$

The force on the "bowl" is therefore

$$\begin{aligned} F_{\text{bowl}} &= \frac{\epsilon_0}{2} \left(\frac{Q}{4\pi\epsilon_0 R} \right)^2 \int_0^{2\pi} \int_0^{\pi/2} \sin \theta \cos \theta d\theta d\phi \\ &= \frac{\epsilon_0}{2} \left(\frac{Q}{4\pi\epsilon_0 R} \right)^2 (2\pi) \int_0^{\pi/2} \sin \theta \cos \theta d\theta \\ &= \frac{1}{4\pi\epsilon_0} \left(\frac{Q^2}{8R^2} \right) \end{aligned}$$