

## JEST - PHYSICS

### MOCK TEST PAPER

- Attempt All the objective questions (Question 50). Question 1 to 25, each of these questions carries one marks. Question 26 to 50 each of these question. carrier three marks, .25 negative mark for each wrong answer.
- Total marks : 100
- Duration of test : 3 Hours

# VPM CLASSES

For IIT-JAM, JNU, GATE, NET, NIMCET and Other Entrance Exams

1-C-8, Sheela Chowdhary Road, Talwandi, Kota (Raj.) Tel No. 0744-2429714

Web Site [www.vpmclasses.com](http://www.vpmclasses.com) E-mail-[vpmclasses@yahoo.com](mailto:vpmclasses@yahoo.com)

- Calculate the frequency of the photon produced when an electron of 20 keV is brought to rest in one collision with a heavy nucleus.  
(A)  $4.84 \times 10^{20}$  Hz  
(B)  $4.84 \times 10^{18}$  Hz  
(C)  $4.84 \times 10^{17}$  Hz  
(D)  $4.84 \times 10^{15}$  Hz
- When a certain metallic surface is irradiated with monochromatic light of wavelength  $\lambda$ , the stopping potential for photoelectric current is  $3V_0$ . When the same surface is irradiated with light of wavelength  $2\lambda$ , the stopping potential is  $V_0$ . The threshold wavelength for the given surface is :  
(A)  $4\lambda$   
(B)  $6\lambda$   
(C)  $8\lambda$   
(D)  $4\lambda/3$
- 1 mole of a monoatomic ideal gas ( $\gamma = 5/3$ ) at  $27^\circ\text{C}$  is adiabatically compressed in a reversible process from initial pressure of 1 atm to final pressure of 50 atm. Calculate the resulting difference of temperature.  
(A) 1134 K  
(B)  $1034^\circ\text{C}$   
(C) 1034 K  
(D)  $1304^\circ\text{C}$
- Find the number of ions in the unit cell of CsCl crystal.  
(A) 2  
(B) 3  
(C) 1  
(D) 4
- There are fourteen Bravais lattices in three dimensions and :  
(A) Four Bravais lattices in two dimension

- (B) Five Bravais lattices in two dimension  
(C) Six Bravais lattices in two dimension  
(D) None of these.
6. The Bragg's angle for (2 2 0) reflection from nickel (f c c) is  $45^\circ$ . When X-rays of wavelength  $1.75 \text{ \AA}$  is employed in a diffraction experiment. What is the lattice constant?  
(A)  $5.2 \text{ \AA}$   
(B)  $3.5 \text{ \AA}$   
(C)  $7.2 \text{ \AA}$   
(D) 0
7. The ratio of the amplitude of the waves scattered by the atom to the amplitude of the wave scattered by a free electron under identical conditions of the incident beam is called :  
(A) Diffraction factor  
(B) Loss factor  
(C) Atomic scattering factor  
(D) None of these
8. A gale blows over the house. The force due to gale on the roof is  
(A) In the downward direction  
(B) In the upward direction  
(C) Zero  
(D) None of the above
9. A wide vessel with a small hole in the bottom is filled with water and kerosene. Neglecting viscosity, the velocity of water flow  $v_1$ , if the thickness of water layer is  $h_1$  and that of kerosene layer is  $h_2$  is (density of water is  $\rho_1 \text{ gm/cc}$  and that of kerosene is  $\rho_2 \text{ gm/cc}$ )

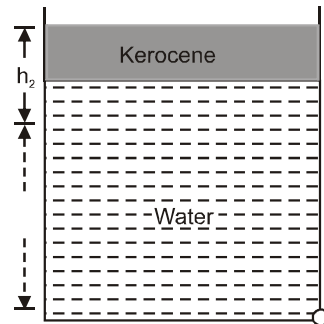

(A)  $v = \sqrt{2g(h_1 + h_2)}$

(B)  $v = \sqrt{2g(h_1\rho_1 + h_2\rho_2)}$

(C)  $v = \sqrt{2g\{h_1 + h_2(\rho_2/\rho_1)\}}$

(D)  $v = \sqrt{2g\{h_1(\rho_1/\rho_2) + h_2\}}$

10. A person normally weighing 60kg stands on a platform which oscillates up and down simple harmonically with a frequency 2 Hz and an amplitude 5cm. If a machine on the platform gives the person's weight, then ( $g = 10 \text{ ms}^{-2}$ ,  $\pi^2 = 10$ )
- (A) maximum reading of the machine is 108 kg  
 (B) maximum reading of the machine is 90 kg  
 (C) minimum reading of the machine is 12kg  
 (D) Both (A) and (C)
11. What is the energy of a typical visible photon ? About how many photons enter the eye per second when one looks at a weak source of light such as the moon, which produces light of intensity of about  $3 \times 10^{-4} \text{ watts/m}^2$  ?
- (A) 2.0 eV,  $2.5 \times 10^7$   
 (B) 2.3 eV,  $2.2 \times 10^{11}$   
 (C) 2.3 eV,  $5.2 \times 11^{10}$   
 (D) 2.3 eV,  $2.5 \times 10^{10}$
12. In case of monoatomic linear lattice what is the ratio of group velocity and particle velocity ( $v_g/v_p$ )?

(A)  $\frac{2 \cos Ka/2}{Ka}$

(B)  $\frac{2 \sin Ka/2}{Ka}$

(C)  $\frac{2 \tan Ka/2}{Ka}$

(D) None

13. For a sphere of radius  $x$ , polarised along the radius vector such that if the total charge is zero then find out  $\vec{D}$ .

(A)  $\frac{\epsilon_r P_0 \vec{r}}{\epsilon_r - 1}$

(B)  $\frac{\epsilon_r \vec{r}}{P_0 (\epsilon_r - 1)}$

(C)  $\frac{\epsilon_r \vec{r}}{P_0 (\epsilon_0 + 1)}$

(D)  $\frac{\epsilon_r \vec{r} P_0}{\epsilon_r + 1}$

14. The bulk n-type and p-type materials of a particular germanium junction have conductivities of  $10^4$  mhos/m and  $10^2$  mhos/m respectively, at 300K. Find the contact potential difference across the junction. Given that intrinsic density of either carrier,  $n_i$  is  $2.5 \times 10^{19}$  /m<sup>3</sup>. Also  $\mu_p = 0.18 \text{m}^2/\text{Vs}$ .

(A) 0.3568 mV

(B) 0.3568  $\mu\text{V}$

(C) 0.3568 V

(D) 0.03568 V

15. At room temperature germanium has a band gap of  $E_g = 0.67$  eV and a conduction electron concentration of about  $n = 2 \times 10^{13}$  cm<sup>-3</sup>. (Note how small this is compared to the range of concentrations in metals,  $10^{22}$  to  $10^{23}$  cm<sup>-3</sup>.) Estimate the conduction electron concentration in diamond, which has a band gap of 5.4 eV.

- (A)  $12^{-28} \text{ cm}^{-3}$   
(B)  $10^{-28} \text{ cm}^{-3}$   
(C)  $20^{-28} \text{ cm}^{-3}$   
(D)  $10^{-19} \text{ cm}^{-3}$
16. Water rises to a height of 13.6 cm in a capillary tube dipped in water. When the same tube is dipped in mercury, it is depressed by  $3\sqrt{2}$  cm. The angle of contact for water is zero and that for mercury  $135^\circ$ . The relative density of mercury is 13.6. The ratio of the surface tensions of mercury and water is
- (A) 4  
(B) 5  
(C) 6  
(D) 7
17. Consider the following statements :
1. Magnus effect is a consequence of Bernoulli's principle .
  2. A cricketer, while spinning a ball makes it to experience Magnus effects .
- Which of the statements given above is/are correct ?
- (A) 1 only  
(B) 2 only  
(C) Both 1 and 2  
(D) Neither 1 nor 2
18. A substance shows Raman frequency shift of  $400 \text{ cm}^{-1}$  if this mode is active in the infrared, then the corresponding infrared absorption band will be at :
- (A)  $0.5 \mu$   
(B)  $1.0 \mu$   
(C)  $1.5 \mu$   
(D)  $2.5 \mu$



19. Calculate the height of an equatorial satellite which is always seen over the same point of earth's surface.  
( $G = 6.66 \times 10^{-11}$  S.I. units,  $M = 5.98 \times 10^{24}$  Kg.)
- (A)  $3.57 \times 10^7$  Km  
(B)  $74.74 \times 10^{21}$  Km  
(C)  $3.57 \times 10^4$  m  
(D)  $74.74 \times 10$  m
20. The shortest distance between two points on the surface of the sphere is the arc of the
- (A) Cycloid  
(B) great circle  
(C) Catenary  
(D) surface area
21. A plane progressive wave is travelling with wave vector  $\vec{k}$ ;  $\hat{n}$  is the unit vector in the direction of amplitude. If the wave is longitudinal, then which one of the following is correct –
- (A)  $\hat{n} \times \vec{k} \neq \vec{0}$ ,  $\hat{n} \cdot \vec{k} = 0$   
(B)  $\hat{n} \times \vec{k} = \vec{0}$ ,  $\hat{n} \cdot \vec{k} = 0$   
(C)  $\hat{n} \times \vec{k} = \vec{0}$ ,  $\hat{n} \cdot \vec{k} \neq 0$   
(D)  $\hat{n} \times \vec{k} \neq \vec{0}$ ,  $\hat{n} \cdot \vec{k} \neq 0$
22. If constraint forces do work and total mechanical energy is not conserved then constraints are named as
- (A) bilateral constraint  
(B) unilateral constraint  
(C) dissipative constraint  
(D) none of these
23. A normally incident E field has amplitude  $E_0^i = 1.0$  V/m in free space just outside of seawater in which  $\epsilon_r = 80$ ,  $\mu_r = 1$ , and  $\sigma = 2.5$  S/m. For a frequency of 30 MHz, at what depth will the amplitude of E be 1.0 m V/m ?

- (A) 0.234 m  
 (B) 2.34 m  
 (C) 23.4 m  
 (D) 234m
24. A telecom-grade single mode fiber has cut-off wavelength at 1260 nm. Find the V-parameter of the fiber at operating wavelength 1310 nm.  
 (A) 2.313 m  
 (B) 2.131  
 (C) 2.313 V  
 (D) 2.313
25. If a proton is fixed in position and an electron revolves about it in a circular path of radius  $0.35 \times 10^{-10}$  m, what is the magnetic field at the proton ?  
 (A) 0.35 T  
 (B) 3.5 T  
 (C) 35 T  
 (D) 350 T
26. Match diagram I with diagram II and select the correct answer using the codes given below for the diagram-I (P – V) and diagram – II (T – S)

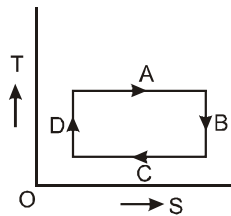
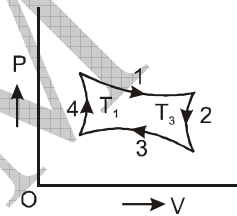

Codes

	a	b	c	d
(A)	1	3	3	4
(B)	2	3	4	1
(C)	3	1	1	2
(D)	4	4	2	3



27. The Wavefunction of an electron in a hydrogen like atom is  $\psi(r) = ce^{-r/a}$  where  $a = \frac{a_0}{z}$   $a_0 = 0.5\text{\AA}$  is the Bohr radius ( the nucleus charge is  $ze$  and the atom contains only one electron) compute the normalization constant.

(A)  $\frac{1}{\sqrt{\pi a^3}}$

(B)  $\frac{1}{\sqrt{2\pi a^3}}$

(C)  $\frac{1}{\sqrt{3\pi a^3}}$

(D)  $\frac{1}{\sqrt{4\pi a^3}}$

28. Consider a wave function for a hydrogen - like atom

$$\psi(r, \theta) = \frac{1}{8L} \sqrt{\frac{2}{\pi}} z^{3/2} (6 - zr) zr e^{-zr/3} \cos \theta$$

where  $r$  is expressed in units of  $a_0$ . Find

the corresponding values of the quantum numbers  $n, \ell$  and  $m$ .

(A)  $n=1, \ell=1, m=1$

(B)  $n=2, \ell=1, m=0$

(C)  $n=2, \ell=2, m=2$

(D)  $n=3, \ell=1, m=0$

29. A region in which  $E > V(x)$ ,  $E < V(x)$  and  $E = V(x)$  are called

(A) Classically allowed region, classically inaccessible, turning points

(B) Classically inaccessible, classically allowed region, turning points

(C) Turning points, classically inaccessible, classically allowed region

(D) Turning points, classically allowed region, classically inaccessible

30. If we consider scattering of particle 1 from particle 2, then the differential cross section in the lab frame and center of mass frame is related by this relation

$$(A) \left( \frac{d\sigma}{d\Omega} \right)^{\text{Lab}} = \frac{(1 + \gamma^2 + 2\gamma \cos \theta)^{3/2}}{1 + \gamma \cos \theta} \left( \frac{d\sigma}{d\Omega} \right)^{\text{CM}}$$

$$(B) \left( \frac{d\sigma}{d\Omega} \right)^{\text{CM}} = \frac{(1 + \gamma^2 + 2\gamma \cos \theta)^{3/2}}{1 + \gamma \cos \theta} \left( \frac{d\sigma}{d\Omega} \right)^{\text{Lab}}$$

$$(C) \left( \frac{d\sigma}{d\Omega} \right)^{\text{Lab}} = \frac{(1 + \gamma \cos \theta)^{3/2}}{1 + \gamma^2 + 2\gamma \cos \theta} \left( \frac{d\sigma}{d\Omega} \right)^{\text{CM}}$$

$$(D) \left( \frac{d\sigma}{d\Omega} \right)^{\text{CM}} = \frac{(1 + \gamma \cos \theta)^{3/2}}{1 + \gamma^2 + 2\gamma \cos \theta} \left( \frac{d\sigma}{d\Omega} \right)^{\text{Lab}}$$

31. Calculate the radiative energy loss per revolution in a circular orbit of radius R meter by an electron of total energy E MeV in the limit  $v \sim c$

$$(A) 8.85 \times 10^{-14} \frac{E}{R} \text{ CV}$$

$$(B) 8.85 \times 10^{-14} \frac{E^4}{R} \text{ MCV}$$

$$(C) 8.85 \times 10^{-8} \frac{E^4}{R} \text{ MCV}$$

$$(D) 8.85 \times 10^{-12} \frac{E^4}{R} \text{ eV}$$

32. If the earth receives  $2 \text{ cal min}^{-1} \text{ cm}^{-2}$  solar energy, what are the amplitudes of electric and magnetic field of radiation .

$$(A) 1027 \text{ v/m} , 2.730 \text{ Amp-turn/m}$$

$$(B) 2.730 \text{ v/m} , 1027 \text{ Amp-turn/m}$$

$$(C) 726.1 \text{ v/m} , 1.928 \text{ Amp-turn/m}$$

$$(D) 1.928 \text{ v/m} , 726.1 \text{ Amp-turn/m}$$

33. A thin semi-circular ring of radius  $R = 15 \text{ cm}$  is uniformly charged with  $q = 5 \times 10^3 \text{ pico farad}$ . Find the magnitude of electric field at the centre of the semicircular ring.
- (A)  $1.27 \text{ Vm}^{-1}$   
 (B)  $1.27 \text{ KVm}^{-1}$   
 (C)  $12.7 \text{ Vm}^{-1}$   
 (D)  $12.7 \text{ KVm}^{-1}$
34. For a point charge moving with constant velocity, obtain an expression for Lienard-Weichert scalar potential for it.
- (A)  $\frac{1}{4\pi\epsilon_0} \frac{qC}{(C^2 (t-t_r) - \vec{r} \cdot \vec{V} - V^2 t_r)}$   
 (B)  $\frac{1}{4\pi\epsilon_0} \frac{qC}{(C^2 (t-t_r) + \vec{r} \cdot \vec{V} - V^2 t_r)}$   
 (C)  $\frac{1}{4\pi\epsilon_0} \frac{qC}{(C^2 (t-t_r) - \vec{r} \cdot \vec{V} + V^2 t_r)}$   
 (D)  $\frac{1}{4\pi\epsilon_0} \frac{qC}{(C^2 (t-t_r) + \vec{r} \cdot \vec{V} + V^2 t_r)}$
35. Which relation is correct for paramagnetic susceptibility  $\chi$
- (A)  $\chi_{\text{pauli}} \propto \frac{T}{T_f} \chi_{\text{classical}}$   
 (B)  $\chi_{\text{classical}} \propto \frac{T}{T_f} \chi_{\text{pauli}}$   
 (C)  $\chi_{\text{pauli}} \propto T T_f \chi_{\text{classical}}$   
 (D)  $\chi_{\text{classical}} \propto T_f T \chi_{\text{pauli}}$
36. Consider two angular momenta, both of magnitude  $J$ . Let  $J = J_1 + J_2$  be the total angular momentum and  $\hat{p}$  the interchange operator defined by  $\hat{p} |m_2 m_1\rangle = |m_2 m_1\rangle$ . find the eigenvalue of  $\hat{p}$ .

- (A) 0
- (B)  $\pm 3$
- (C)  $\pm 1$
- (D)  $\pm 2$

37. Using the semiclassical approximation , calculate the transmission coefficient of a potential barrier

$$V(x) = \begin{cases} V_0 \left(1 - \frac{x^2}{a^2}\right) & -a \leq x \leq a \\ 0 & \text{otherwise} \end{cases}$$

(A)  $T = \exp \left[ \pi \sqrt{\frac{2m}{V_0}} \frac{a(V_0 - E)}{\hbar} \right]$

(B)  $T = \exp \left[ -\pi \sqrt{\frac{2m}{V_0}} \frac{a(V_0 - E)}{\hbar} \right]$

(C)  $T = \exp \left[ \frac{1}{\pi} \sqrt{\frac{2m}{V_0}} \frac{a(V_0 - E)}{\hbar} \right]$

(D)  $T = \exp \left[ -\frac{1}{\pi} \sqrt{\frac{2m}{V_0}} \frac{a(V_0 - E)}{\hbar} \right]$

38. A symmetrical top with moments of inertia  $I_x = I_y$  and  $I_z$  in the body axes frame is described by the Hamiltonian

$$H = \frac{1}{2I_x} (L_x^2 + L_y^2) + \frac{1}{2I_z} L_z^2$$

note that moments of inertia are parameters and not operators .  $L_x$  ,  $L_y$  and  $L_z$  are the angular momentum operators in the body axes frame . Calculate the eigenvalue of the hamiltonian ?

(A)  $\frac{m^2 \hbar^2}{2I_x} + \frac{\hbar^2}{2I_z} [\ell(\ell + 1) - m^2]$

(B)  $\frac{\hbar^2}{2I_x} [\ell(\ell + 1) - m^2] + \frac{m(m + 1) \hbar^2}{2I_z}$

(C)  $\frac{\hbar^2}{2I_x} \ell(\ell+1) + \left( \frac{1}{2I_z} - \frac{1}{2I_x} \right) \hbar^2 m^2$

(D)  $\frac{\hbar^2}{2I_x} \ell(\ell+1) + \left( \frac{1}{2I_x} - \frac{1}{2I_z} \right) \hbar^2 m^2$

39. The spherical harmonic functions are defined by

$$Y_l^m(\theta, \phi) = C_l^m P_l^m(\cos \theta) e^{im\phi}$$

where  $C_l^m$  is a normalization constant and  $P_l^m(x)$  are the associated Legendre function defined by

$$P_l^m(x) = (1-x^2)^{|m|/2} \frac{d^{|m|}}{dx^{|m|}} P_l(x) = P_l^m(x)$$

compute the function  $Y_l^m(\theta, \phi)$  for  $m = 0, \pm 1$ .

(A)  $\sqrt{\frac{3}{4\pi}} \cos \theta, \sqrt{\frac{3}{8\pi}} \sin \theta e^{i\phi}, \sqrt{\frac{3}{8\pi}} \sin \theta e^{-i\phi}$

(B)  $\sqrt{\frac{3}{4\pi}} \sin \theta, \sqrt{\frac{3}{8\pi}} \cos \theta e^{i\phi}, \sqrt{\frac{3}{8\pi}} \cos \theta e^{-i\phi}$

(C)  $\sqrt{\frac{3}{4\pi}} \cos \theta, \sqrt{\frac{3}{8\pi}} \sin \theta e^{-i\phi}, \sqrt{\frac{3}{8\pi}} \cos \theta e^{-i\phi}$

(D)  $\sqrt{\frac{3}{4\pi}} \sin \theta, \sqrt{\frac{3}{8\pi}} \cos \theta e^{i\phi}, \sqrt{\frac{3}{8\pi}} \sin \theta e^{-i\phi}$

40. Using Rodrique's formula, solve this integral

$$\int_{-1}^1 x^2 P_5(x) dx$$

(A) 2

(B) 1

(C)  $\frac{1}{2}$

(D) 0

41. Bromwich integral is defined as

$$(A) F(t) = \frac{1}{2\pi i} \int_{C-i\infty}^{C+i\infty} f(s)e^{st} ds$$

$$(B) F(t) = \frac{1}{2\pi i} \int_{-i\infty}^{i\infty} f(s)e^{st} ds$$

$$(C) F(t) = \frac{1}{2\pi i} \int_{C-i\infty}^{C+i\infty} f(s)e^{-st} ds$$

$$(D) F(t) = \frac{1}{2\pi i} \int_{-i\infty}^{+i\infty} f(s)e^{-st} ds$$

42. Which function is the generating function of Hermite polynomial.

(A)  $e^{2zx-z^2}$

(B)  $e^{2zx+z^2}$

(C)  $e^{zx-z^2}$

(D)  $e^{zx+z^2}$

43. Find out the distance of closest approach of a 3 MeV proton to a gold nucleus.

(A)  $0.5 \times 10^{-12}$  m

(B)  $0.5 \times 10^{-13}$  m

(C)  $1.5 \times 10^{-12}$  m

(D)  $1.5 \times 10^{-13}$  m

44. Compare the radius of the  ${}_{79}\text{Au}^{197}$  nucleus with the radius of its innermost Bohr orbit.

(A) 95 times

(B) 96 times

(C) 97 times

(D) 98 times

45. Find out the Larmor frequency of a proton in a magnetic field of magnitude  $4 \times 10^{-5}$  T.

(A) 1.70 KHz

(B) 1.70 Hz

(C) 3.15 KHz

(D) 3.15 Hz

46. What is the quiescent collector current in Fig ? The maximum efficiency of the amplifier ?
- (A) 2.38 mA, 78%  
 (B) 2.38 mA, 78.1%  
 (C) 2.38A, 78.2%  
 (D) 2.38A, 78.3%

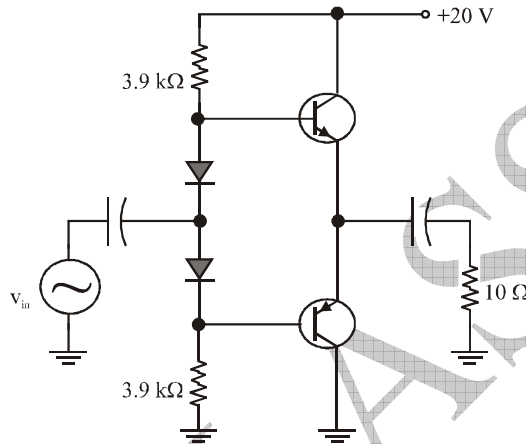

47. Calculate the range of nuclear forces if a nucleon emits a virtual pion of rest mass  $271 m_e$ .
- (A) 1.42 m  
 (B) 1.40 m  
 (C) 1.42 Fermi  
 (D) 1.40 Fermi
48. Find out the radius of deuteron in rectangular well model by using the condition that for the ground level  $b = \lambda/4 = \pi/2k$ .
- (A)  $\frac{2bv_0^{1/2}}{\pi} B^{1/2}$   
 (B)  $\frac{bv_0^{1/2}}{2\pi} B^{1/2}$   
 (C)  $\frac{2bv_0^{1/2}}{b\pi} B^{1/2}$



(D)  $\frac{2v_0^{1/2}}{b} B^{1/2}$

49. Find out the mass in kg of one Curie in a sample of  $\text{Ra}^{226}$  having half life of 1620 years.
- (A)  $1.02 \times 10^{-3}$  kg  
(B)  $1.02 \times 10^{-4}$  kg  
(C)  $1.02 \times 10^{-3}$  gm  
(D)  $1.02 \times 10^{-4}$  gm
50. The kaons having kinetic energy of 6000 MeV travel at a relativistic speed through 150 m of an evacuated beam tube to reach a bubble chamber . By what factor the intensity of the kaon beam diminished while the particles were travelling to bubble chamber. Half life of kaons =  $8.6 \times 10^{-9}$  s. Rest mass energy of kaon = 494 MeV.
- (A) 0.047%  
(B) 0.47%  
(C) 4.7%  
(D) 47%

## ANSWER KEY

Question	1	2	3	4	5	6	7	8	9	10	11	12	13	14	15
Answer	B	A	A	A	B	B	C	B	C	D	D	C	A	C	B
Question	16	17	18	19	20	21	22	23	24	25	26	27	28	29	30
Answer	C	C	B	A	B	C	C	A	D	C	A	A	D	A	A
Question	31	32	33	34	35	36	37	38	39	40	41	42	43	44	45
Answer	B	A	B	A	A	C	B	C	A	D	A	A	D	B	A
Question	46	47	48	49	50										
Answer	B	C	A	A	B										

## HINTS AND SOLUTION

1.(B) Assuming all the kinetic energy of the electron is used to produce the photon, we have

$$E_{\text{initial}} = E_{\text{final}}$$

$$K + m_0c^2 = hv + m_0c^2$$

$$20 \times 10^3 \text{ eV} = (4.136 \times 10^{-15} \text{ eV}) \nu$$

$$\nu = 4.84 \times 10^{18} \text{ Hz}$$

2.(A) **Photoelectric Effect** : When a beam of light of frequency in the blue or ultraviolet region falls on metal plate, slow moving electrons are emitted from this metal surface. The phenomenon is known as photoelectric effect and the electrons emitted are known as photoelectrons. The minimum frequency of the ray which emits an electron is called threshold frequency and this is different for different metals. The energy corresponding to this threshold frequency is called work function. If  $\nu$  is frequency of incident light and  $\nu_0$  is threshold frequency, the energy carried out by emitted electrons

$$= h\nu - h\nu_0$$

$h \rightarrow$  Planck's constant

$$\Rightarrow \text{Energy of photoelectron} = h(\nu - \nu_0)$$

To stop photo electric effect, we have to apply a potential which is equivalent to the energy of photoelectrons, This potential is called stopping potential.

$$\text{Hence, stopping potential} = h(\nu - \nu_0)$$

$$V = hc \left( \frac{1}{\lambda} - \frac{1}{\lambda_0} \right) \quad \left( \text{since } v = \frac{c}{\lambda_0} \right)$$

According to question,

$$3V_0 = hc \left( \frac{1}{\lambda} - \frac{1}{\lambda_0} \right) \quad V_0 = hc \left( \frac{1}{2\lambda} - \frac{1}{\lambda_0} \right)$$

Dividing we have,

$$3 = \frac{\left( \frac{1}{\lambda} - \frac{1}{\lambda_0} \right)}{\left( \frac{1}{2\lambda} - \frac{1}{\lambda_0} \right)}$$

$$\Rightarrow 3 \left( \frac{1}{2\lambda} - \frac{1}{\lambda_0} \right) = \left( \frac{1}{\lambda} - \frac{1}{\lambda_0} \right) \Rightarrow \frac{3}{2\lambda} - \frac{3}{\lambda_0} = \frac{1}{\lambda} - \frac{1}{\lambda_0}$$

$$\Rightarrow \frac{3}{2\lambda} - \frac{1}{\lambda} = \frac{3}{\lambda_0} - \frac{1}{\lambda_0} \Rightarrow \frac{1}{2\lambda} = \frac{2}{\lambda_0} \Rightarrow \lambda_0 = 4\lambda$$

3.(A) We have  $p_1 = 1 \text{ atm}$ ,  $p_2 = 50 \text{ atm}$ ,  $T_1 = 273 + 27 = 300 \text{ K}$ ,  $T_2 = ?$

$$\left( \frac{p_2}{p_1} \right)^{\gamma-1} = \left( \frac{T_2}{T_1} \right)^{\gamma} \quad \text{or } (50)^{\frac{5}{3}-1} = \left( \frac{T_2}{300} \right)^{5/3} \quad \text{or } \frac{2}{3} \log 50 = \frac{5}{3} (\log T_2 - \log 300)$$

$$\text{or } \frac{2}{3} \times 1.6990 = \frac{5}{3} \log T_2 - \frac{5}{3} \times 2.4771 \quad \text{or } \frac{5}{3} \log T_2 = 5.2611. \quad \therefore$$

$$\log T_2 = 3.1566 \quad \therefore \log T_2 = 1434 \text{K}$$

$$\therefore \text{Difference in temperature} = 1434 - 300 = 1134 \text{K}$$

4.(A) In CsCl there is one molecule per primitive cell with coordinates of atoms (0, 0, 0) and

$\left( \frac{1}{2}, \frac{1}{2}, \frac{1}{2} \right)$  of the simple cubic space lattice. Each atom is at the centre of the cube of atoms

of the opposite kind. Hence ions are 2.

5(B) Five bravais lattice in two dimension

- |                       |                           |
|-----------------------|---------------------------|
| (1) oblique lattice   | (2) Square lattice        |
| (3) Hexagonal lattice | (4) Primitive rectangular |

(5) Centred rectangular

6.(B) Bragg's law is  $2d \sin \theta = n\lambda$  and  $d = \frac{a}{\sqrt{h^2 + k^2 + l^2}}$ . For  $n = 1$  we have  $\frac{2a}{\sqrt{h^2 + k^2 + l^2}} \sin \theta = \lambda$  or

$$a = \frac{\lambda}{2 \sin \theta} \cdot \sqrt{h^2 + k^2 + l^2} \text{ or } a = \frac{1.75 \times 2\sqrt{2}}{2 \cdot \frac{1}{\sqrt{2}}} = 2 \times 1.75 = 3.5 \text{ \AA}.$$

7.(C) Incident beam is called atomic scattering factor.

$$f = \frac{\text{Amplitude of radiation scattered by an atom}}{\text{Amplitude of radiation scattered by an isolated electron}}$$

8.(B) There will be less pressure on the roof and more below the roof due to gale blowing. Hence thrust acts upwards.

9.(C) Net pressure at the bottom =  $h_1 \rho_1 g + h_2 \rho_2 g$

Applying Bernoulli's theorem

$$h_1 \rho_1 g + h_2 \rho_2 g = \frac{1}{2} \rho_1 v^2$$

$$\therefore v = \sqrt{2g\{h_1 + h_2(\rho_2/\rho_1)\}}$$

10.(D) Reading will be maximum when platform accelerates up and minimum when it accelerates down. So,

$$R_{\max} = m (g + a\omega^2) \quad \{\because \text{maximum acceleration} = a\omega^2\}$$

$$\Rightarrow R_{\max} = 60 [10 + 8]$$

$$\Rightarrow R_{\max} = 1080 \text{ N}$$

$$\Rightarrow \text{Reading} = 108 \text{ Kg}$$

Similarly

$$\Rightarrow R_{\min} = m (g - a\omega^2)$$

$$\Rightarrow R_{\min} = 60 (10 - 8)$$

$$\Rightarrow R_{\min} = 120 \text{ N}$$

$$\Rightarrow \text{Reading} = 12 \text{ kg}$$

**11.(D)** The wavelength of visible light is between 400 and 700 nm. Thus we can take a typical visible wavelength to be

$$\lambda = 550 \text{ nm} \quad (1)$$

The energy of a single photon is  $E = hv = \frac{hc}{\lambda}$  (2)

Before we evaluate this, it is useful to note that the product  $hc$  enters into many calculations and is a useful combination to remember. Since  $h$  has the dimension energy  $\times$  time,  $hc$  has the dimension energy  $\times$  length and is conveniently expressed in eV $\cdot$ nm, as follows

$$hc = (6.63 \times 10^{-34} \text{ J}\cdot\text{s}) \times (3.00 \times 10^8 \text{ m/s}) \times \frac{1\text{eV}}{1.60 \times 10^{-19} \text{ J}} = 1.24 \times 10^{-6} \text{ eV}\cdot\text{m}$$

or  $hc = 1240 \text{ eV}\cdot\text{nm}$  (3)

Putting numbers into (2), we find the energy for a typical visible photons to be

$$E = \frac{hc}{\lambda} \approx \frac{1240 \text{ eV}\cdot\text{nm}}{550 \text{ nm}} \approx 2.3 \text{ eV} \quad (4)$$

On the atomic level this energy is significant, but by everyday standards it is extremely small. When we look at the moon, the energy entering our eye per second is given by  $IA$ , where  $I$  is the intensity ( $I \approx 3 \times 10^{-4} \text{ W/m}^2$ ) and  $A$  is the area of the pupil ( $A \approx 3 \times 10^{-5} \text{ m}^2$  if we take the diameter of the pupil to be about 6mm). Thus the number of photons entering our

$$\text{eye per second is number of photons per second} = \approx \frac{(3 \times 10^{-4} \text{ W/m}^2) \times (3 \times 10^{-5} \text{ m}^2)}{(2.3 \times 1.6 \times 10^{-19} \text{ J})}$$

$$\approx 2.5 \times 10^{10}$$

photons per second

This is such a large number that the restriction to integer numbers of photons is quite unimportant even for this weak source.

**12.(C)** The dispersion relation is  $\omega = \pm \sqrt{\frac{4f}{M}} \sin \frac{Ka}{2}$ . For  $K \ll \frac{\pi}{a}$  i.e for long wave lengths  $\sin$

$$\frac{Ka}{2} \approx \frac{Ka}{2} \text{ and } \omega = \pm \sqrt{\frac{f}{M}} Ka \text{ and } v_p = v_g = \sqrt{\frac{f}{M}} a = v_0. \text{ For short wavelengths}$$

$$v_g = \frac{\omega}{K} = a \sqrt{\frac{f}{M}} \cdot \frac{\sin Ka/2}{Ka/2} = v_0 \frac{\sin Ka/2}{Ka/2} \text{ and } v_p = \frac{d\omega}{dk} = v_0 \cos Ka/2 \text{ and } v_g/v_p = \frac{2 \tan Ka/2}{Ka}.$$

13.(A) We know that

$$\text{Total charge} = \int \rho_p dV + \int \sigma_p dS \quad \dots(1)$$

$$\text{So } \rho_p = -\text{div } \vec{p} = -P_0 \vec{\nabla} \cdot \vec{r} = -P_0 \left( \frac{\partial}{\partial x} \hat{i} + \frac{\partial}{\partial y} \hat{j} + \frac{\partial}{\partial z} \hat{k} \right)$$

$$\left( x\hat{i} + y\hat{j} + z\hat{k} \right) = -3P_0 \text{ and } \sigma_p = \hat{n} \cdot \vec{p} = P_0 \hat{n} \cdot \vec{r} = P_0 x$$

Putting these in (1), we get

$$-3P_0 \times \frac{4}{3} \pi x^3 + P_0 x \cdot 4\pi x^2 = 0$$

$$\text{Also } \vec{D} = \epsilon \vec{E} \text{ and } \vec{E} = \frac{\vec{P}}{\epsilon_0 \chi_e} = \frac{\vec{P}_0 \vec{r}}{\epsilon - \epsilon_0}$$

$$\text{So } \vec{D} = \frac{\epsilon \vec{P}_0 \vec{r}}{\epsilon_0 - \epsilon_0} = \frac{\epsilon_r P_0 \vec{r}}{\epsilon_r - 1}$$

14.(C) Almost entire current is carried by majority carriers in an impurity semiconductor .

Therefore

$$N_d = \frac{\sigma_n}{e\mu_n} = \frac{10^4}{1.6 \times 10^{-19} \times 0.38} = 1.643 \times 10^{23} \text{ per m}^3$$

$$\text{and } N_a = \frac{\sigma_p}{e\mu_p} = \frac{10^2}{1.6 \times 10^{-19} \times 0.18} = 3.468 \times 10^{21} \text{ per m}^3$$

At 300 K

$$\frac{K_B T}{e} = 0.0258$$

so that contact potential difference is

$$V_{B0} = \frac{K_B T}{e} \log_e \left( \frac{N_d N_a}{n_i^2} \right)$$

$$= 0.0258 \times \log_e \left[ \frac{1.643 \times 10^{23} \times 3.468 \times 10^{21}}{(2.5 \times 10^{19})^2} \right]$$

$$= 0.0258 \times \log_e (0.912 \times 10^6)$$

$$= 0.3568 \text{ volt.}$$

15.(B) Using equation  $n \propto e^{-E_g/(2kT)}$ , we can set up an approximate ratio of conduction electron concentration in two different materials, which we label 1 and 2 :

$$\frac{n_2}{n_1} \approx \frac{e^{-E_2/2kT}}{e^{-E_1/2kT}} = e^{-(E_2-E_1)/2kT} \quad (1)$$

This relation is only approximate because the proportionality constant varies from material to material by a factor of 10 or so ; however, the exponential factor usually dominates the behavior as this example will show comparing germanium and diamond, the band gap difference is  $5.4 \text{ eV} - 0.7 \text{ eV} = 4.7 \text{ eV}$ . With  $kT_{\text{room}} = 0.025 \text{ eV}$ , equation (1) becomes  $n_{\text{diamond}} \approx n_{\text{Ge}} e^{-(4.7)/(2 \times 0.025)} = (2 \times 10^{13} \text{ cm}^{-3}) e^{-94} \approx 10^{-28} \text{ cm}^{-3}$

This is such an infinitesimal concentration (much less than one electron per cubic kilometer of diamond ! ) that the conduction electron density in pure diamond can be taken to be zero. Actual diamond samples have a carrier concentration much greater than this (still tiny), but this is due to unavoidable impurities, not thermal activation across the band gap.

16.(C) We know that

$$\sigma_1 = \frac{h_1 \rho_1 g r}{2 \cos \theta_1} \quad \sigma_2 = \frac{h_2 \rho_2 g r}{2 \cos \theta_2}$$

$$\frac{\sigma_2}{\sigma_1} = \frac{h_2}{h_1} \cdot \frac{\rho_2}{\rho_1} \cdot \frac{\cos \theta_1}{\cos \theta_2}$$

Given  $h_1 = 13.6 \text{ cm}$ ,  $h_2 = -3\sqrt{2} \text{ cm}$ ,  $\frac{\rho_2}{\rho_1} = 13.6$ ,  $\theta_1 = 0$ ,  $\theta_2 = 135^\circ$

$$\text{then } \frac{\sigma_2}{\sigma_1} = \frac{3\sqrt{2}}{13.6} \times 13.6 \times \frac{\cos 0}{\cos 135}$$

$$= -3\sqrt{2} \times \frac{-\sqrt{2}}{1} = 6$$

17.(C) The spinning ball takes a curved shape . If a ball or a sphere , be spinning about an axis through it, perpendicular to the plane of paper . The air surrounding it is also set in motion , the streamline taking the form of the concentric circles in the planes parallel to the plane of paper , their direction being the same as that of the spin of the ball.



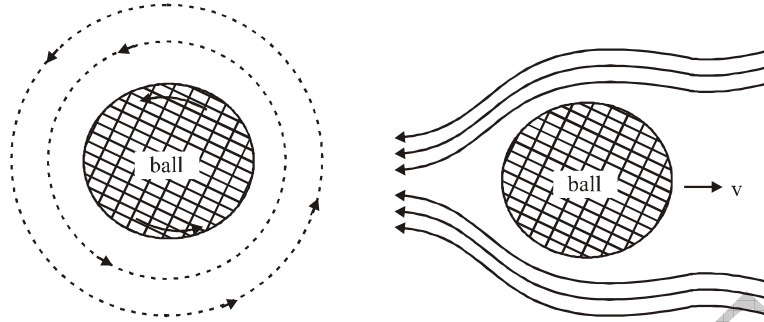

However if ball be given only a linear forward motion, it pushes aside the air in front of it and air flows in opposite direction to the motion .

When these two motion are combined the streamline due to two motions run in opposite direction of the under side of the ball, but in same direction on its upper side. Thus, there is a decrease of velocity or increase of pressure on its under and an increase of velocity or decrease of pressure on its upper side .As a result the ball experiences a lift and takes a curved path upward convex to the under . The effect is called Magnus effect .

- 18.(B)** When an intense beam of monochromatic light is scattered by a liquid , the spectrum of scattered radiations contains lines whose wave lengths are longer and shorter than the incident radiation . This effect is known as Raman effect .

The absorbing power of infrared is given as

$$I = I_0 e^{-\mu x} \text{ and is equal to one micro .}$$

- 19.(A)** Let the height of the equatorial satellite be h. The equatorial is seen over the same point of earth's surface i.e. the angular velocity of satellite is the same as that of the earth itself  
Hence angular velocity of the satellite

$$\omega = \frac{2\pi}{24 \times 60 \times 60} = 7.27 \times 10^{-5} \text{ sec}^{-1}$$

Also  $\frac{GMm}{r^2} = m\omega^2 r$

$$\text{or } r^3 = \frac{GM}{\omega^2} = \frac{6.66 \times 10^{-11} \times 5.98 \times 10^{24}}{(7.27 \times 10^{-5})^2} = 74.74 \times 10^{21}$$

where  $r = 4.21 \times 10^7 \text{ m}$

$$\begin{aligned} h &= r - R \\ &= 4.21 \times 10^7 - 6.4 \times 10^6 \\ &= 3.57 \times 10^7 \text{ m} \\ &= 3.57 \times 10^7 \text{ km} \end{aligned}$$

20.(B)  $dS^2 = a^2 (d\theta^2 + \sin^2\theta d\phi^2)$

or  $dS = a d\theta \sqrt{1 + \sin^2\theta \dot{\phi}^2}$

according to the variational principle

$$\delta s = \delta \int ds = \delta \int a d\theta \sqrt{1 + \sin^2\theta \dot{\phi}^2} = 0$$

or  $\delta \int_{\theta_1, \phi_1}^{\theta_2, \phi_2} d\theta \sqrt{1 + \sin^2\theta \dot{\phi}^2} = 0$

Here  $f = \sqrt{1 + \sin^2\theta \dot{\phi}^2}$ ;  $\therefore \frac{\partial f}{\partial \phi} = 0$  and

$$\frac{\partial f}{\partial \phi} = \frac{\phi \sin^2 \theta}{\sqrt{1 + \sin^2 \theta \phi'^2}}$$

Now,  $\frac{\partial f}{\partial \phi} - \frac{d}{d\theta} \left( \frac{\partial f}{\partial \phi'} \right) = 0$

or  $\frac{\phi' \sin^2 \theta}{\sqrt{1 + \sin^2 \theta \phi'^2}} = c$

or  $\phi' = \frac{c \operatorname{cosec}^2 \theta}{(1 - c^2 - c^2 \cot^2 \theta)^{1/2}} = \frac{d\phi}{d\theta}$

$\therefore \phi = \alpha - \sin^{-1}(c' \cot \theta)$

where  $\alpha$  and  $c'$  are constants and these may be fixed by limits  $\theta_1, \phi_1$  and  $\theta_2, \phi_2$

$$c' \cot \theta = \sin(\alpha - \phi) \text{ or } c' r \cos \theta = r \sin(\alpha - \phi) \sin \theta$$

or  $c' r \cos \theta = \sin \alpha r \cos \phi \sin \theta - \cos \alpha r \sin \phi \sin \theta$

or  $c' z = x \sin \alpha - y \cos \alpha$

where we have transformed from spherical coordinates to cartesian coordinates.

The above equation represents a plane passing through the origin (0, 0, 0). This plane will cut the surface of the sphere in a great circle (whose centre is at the origin). This indicates

that the shortest or longest distance between two points on the surface of the sphere is an arc of the circle with its centre at the origin.

21.(C) The plane progressive wave is written as  $y = a \sin(kx - \omega t)$

$k$   $\longrightarrow$  wave vector

$\omega$   $\longrightarrow$  angular velocity

$a$   $\longrightarrow$  amplitude

The wave vector  $\vec{k}$  is along the motion of the wave hence if  $\hat{n}$  unit vector in direction of amplitude then it is also in the direction of the propagation of the wave for longitudinal wave as it is cleared from the figure.

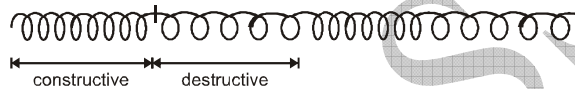

Thus,  $\hat{n}$  and  $\hat{k}$  is in same direction hence,

(i)  $\hat{n} \times \vec{k} = 0$

(ii)  $\hat{n} \cdot \vec{k} \neq 0$

22.(C) Because total energy is not conserved it means dissipation takes place, hence constraints are dissipative.

23.(A) Let the free space be region 1 and the seawater be region 2.

$$\eta_1 = 377 \Omega \quad \eta_2 = 9.73 \angle 43.5^\circ \Omega$$

Then the amplitude of E just inside the seawater is  $E_0^t$ .

$$\frac{E_0^t}{E_0^i} = \frac{2\eta_2}{\eta_1 + \eta_2} \quad \text{or} \quad E_0^t = 5.07 \times 10^{-2} \text{ V/m}$$

$$\text{From } \gamma = \sqrt{j\omega\mu(\sigma + j\omega\epsilon)} = 24.36 \angle 46.53^\circ \text{ m}^{-1}.$$

$$\alpha = 24.36 \cos 46.53^\circ = 16.76 \text{ Np/m}$$

The , from

$$1.0 = 10^{-3} = (5.07 \times 10^{-2}) e^{-16.76z}$$

$$z = 0.234 \text{ m.}$$

**24.(D)** V-parameters at any two wavelength are related as  $V_1\lambda_1 = V_2\lambda_2$ . In the above problem  $V_2 = V_c = 2.405$  at  $\lambda_2 = 1260$  nm.

$$\therefore V_1 = (2.405 \times 1260 / 1310) = 2.313$$

**25.(C)** The proton and electron are attracted by the coulomb force,

$$F = \frac{Q^2}{4\pi\epsilon_0 r^2}$$

which furnishes the centripetal force for the circular motion Thus

$$\frac{Q^2}{4\pi\epsilon_0 r^2} = m_e \omega^2 r \quad \text{or} \quad \omega^2 = \frac{Q^2}{4\pi\epsilon_0 m_e r^3}$$

Now, the electron is equivalent to a current loop  $I = (\omega/2\pi)Q$ . The field at the center of such a loop is ,

$$B = \mu_0 H = \frac{\mu_0 I}{2r} = \frac{\mu_0 \omega Q}{4\pi r}$$

Substituting the value of  $\omega$  found above ,

$$B = \frac{(\mu_0/4\pi)Q^2}{r^2 \sqrt{4\pi\epsilon_0 m_e} r} = \frac{(10^{-7})(1.6 \times 10^{-19})^2}{(0.35 \times 10^{-10})^2 \sqrt{\left(\frac{1}{9} \times 10^{-9}\right)(9.2 \times 10^{-31})(0.35 \times 10^{-10})}} = 35 \text{ T}$$

**26.(A)** P-V diagram for carnot cycle

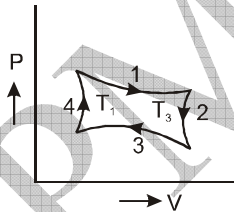

For diagram – I the process are as following

- 1 → Isothermal expansion
- 2 → Adiabatic expansion
- 3 → Isothermal compression
- 4 → Adiabatic compression

T–S diagram for carnot engine (cycle)

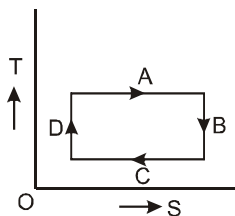

For diagram – II the process are as following

- A – Isothermal expansion
- B – Adiabatic expansion
- C – Isothermal compression
- D – Adiabatic compression

So, compare the process of diagram – I and diagram – II, we get

$$A \rightarrow 1, B \rightarrow 2, C \rightarrow 3, D \rightarrow 4$$

27.(A) The normalization condition is  $\iiint \psi^* \psi d^3r = 1$

substituting  $\psi$  then

$$c^2 \int_0^\infty r^2 e^{-2r/a} dr \int_0^{2\pi} d\phi \int_0^\pi \sin\theta d\theta$$

$$= 4\pi c^2 \int_0^\infty r^2 e^{-2r/a} dr = 1$$

$$\text{the integral } \int_0^\infty r^2 e^{-2r/a} dr = \left(\frac{a}{2}\right)^3 \sqrt{3} = \frac{a^3}{8} 2!$$

$$\text{therefore } c = \left(\frac{1}{4\pi} \frac{4}{a^3}\right)^{1/2} = \frac{1}{\sqrt{\pi a^3}}$$

28.(D) consider the exponential factor in  $\psi(r, \theta)$  it has the form  $\exp(-\sqrt{-Er})$

$$\text{since } E = -\frac{Z^2}{n^2}$$

we conclude that  $n=3$

The angular quantum number can be determined by

$$L^2 \psi(\theta, \phi) = L^2 E(\theta) \cos\theta = f(\theta) \left[ -\frac{1}{\sin\theta} \frac{\partial}{\partial \theta} \left( \sin\theta \frac{\partial}{\partial \theta} \cos\theta \right) \right]$$

$$= 2 f(\theta) \cos\theta = l(l+1) \psi(\theta, \phi)$$

thus  $l=1$

The magnetic quantum number can be determined by

$$L_z \psi(r, \theta) = -\frac{\partial}{\partial \phi} [f(r) \cos \theta] = 0 = m \psi(r, \theta)$$

so  $m=0$

**29.(A)** From the theory of WKB approximation

A region in which  $E > v(x)$  is called a classically allowed region of motion

A region in which  $E < v(x)$  is called classically inaccessible

The points in the boundary between these two kinds of region are called turning points where  $E = v(x)$

**30.(A)** Relation between differential cross section in the lab frame and center of mass frame

$$\left(\frac{d\sigma}{d\Omega}\right)^{\text{Lab}} = \frac{(1+\gamma^2+2\gamma\cos\theta)^{3/2}}{(1+\gamma\cos\theta)} \left(\frac{d\sigma}{d\Omega}\right)^{\text{CM}}$$

where  $\theta$  = scattering angle in the CM frame

$$\gamma = m_1/m_2$$

$$\mathbf{31.(B)} P = \frac{e^2}{6\pi\epsilon_0} \cdot \frac{\beta^4 c}{R^2} \cdot \frac{1}{(1-\beta^2)^2}$$

where  $a = \frac{v^2}{R}$  and  $\beta = \frac{v}{c}$ .

From theory of relativity, we know

$$E = \frac{mc^2}{\sqrt{1-\beta^2}} = \frac{E_0}{\sqrt{1-\beta^2}}$$

$$\therefore \frac{1}{(1-\beta^2)^2} = \left(\frac{E}{E_0}\right)^4$$

$$\text{Thus } P = \frac{e^2}{6\pi\epsilon_0} \cdot \frac{\beta^4 c}{R^2} \cdot \left(\frac{E}{E_0}\right)^4$$

Since the time taken for one revolution is  $T = \frac{2\pi R}{v}$ , so the energy radiated per revolution is given by

$$\begin{aligned}\Delta E = P \cdot T &= \frac{e^2}{6\pi\epsilon_0} \cdot \frac{\beta^4 c}{R^2} \cdot \left(\frac{E}{E_0}\right)^4 \cdot \frac{2\pi R}{v} \\ &= \frac{e^2}{3\epsilon_0} \cdot \frac{\beta^4}{R} \left(\frac{E}{E_0}\right)^4.\end{aligned}$$

In the limit  $v \sim c, \beta \rightarrow 1$ , so

$$\Delta E = \frac{e^2}{3\epsilon_0 R} \left(\frac{E}{E_0}\right)^4.$$

For an electron

$$e = 1.6 \times 10^{-19} \text{ C}, E_0 = 0.51 \text{ MeV}$$

$$\begin{aligned}\Delta E &= 8.85 \times 10^{-8} \frac{E^4}{R} \text{ eV} \\ &= 8.85 \times 10^{-14} \frac{E^4}{R} \text{ McV}.\end{aligned}$$

**32.(A)** From Poynting theorem, the energy flux per unit area per second is

$$\begin{aligned}|S| &= |E \times H| \\ &= EH \sin 90^\circ \\ &= EH\end{aligned}\quad \dots(1)$$

The energy flux per unit area per second at earth is given =  $2 \text{ cal min}^{-1} \text{ sec}^{-2}$

$$= \frac{2 \times 4.2 \times 10^4}{60} \text{ Joules m}^{-2} \text{ sec}^{-1}\quad \dots(2)$$

Comparing (1) and (2), we get

$$\begin{aligned}EH &= \frac{2 \times 4.2 \times 10^4}{60} \\ &= 1400\end{aligned}$$

...(3)



Also 
$$\frac{E}{H} = \sqrt{\frac{\mu_0}{\epsilon_0}}$$

$$= \sqrt{\frac{4\pi \times 10^{-7}}{8.85 \times 10^{-12}}} = 376.6 \quad \dots(4)$$

Multiplying equation (3) and (4), we get

$$E^2 = 1400 \times 376.6$$

or 
$$E = \sqrt{1400 \times 376.6}$$

$$= 726.1 \text{ volt/m}$$

Putting this value (3), we get

$$H = \frac{1400}{E}$$

$$= \frac{1400}{726.1} = 1.928 \text{ amp-turn /m}$$

Amplitudes of electric and magnetic field of radiation are

$$E_0 = E \sqrt{2}$$

$$= 726.1 \sqrt{2}$$

$$= 1027 \text{ volt/m}$$

$$H_0 = H \sqrt{2}$$

$$= 1.928 \sqrt{2}$$

$$= 2.730 \text{ amp-turn/m}$$

33.(B) Choose a small element  $dl$  on the wire and angles as shown in the figure.

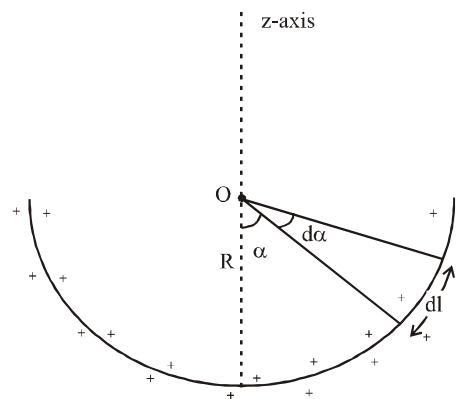

Let  $dq$  = Small charge on the element

$$= \lambda dl \text{ (where } \lambda = \frac{q}{\pi R}, \text{ the linear charge density)}$$

$$= \frac{q}{\pi R} (R d\theta) \quad \left[ \text{Since } d\theta = \frac{d\theta}{R} \right]$$

$$= \frac{q}{\pi} d\theta$$

Now, electric field at point O (centre) due to semicircular ring

$$= \int_{-\pi/2}^{+\pi/2} \frac{1}{4\pi\epsilon_0} \frac{dq}{R^2} \cos \theta$$

$$= \int_{-\pi/2}^{+\pi/2} \frac{1}{4\pi\epsilon_0} \frac{dq}{R^2} \cos \theta d\theta$$

$$= \frac{1}{4\pi\epsilon_0} \frac{q}{\pi R^2} \int_{-\pi/2}^{+\pi/2} \cos \theta d\theta = \frac{1}{4\pi\epsilon_0} \frac{2q}{\pi R^2}$$

$$\text{Therefore, } E = 9 \times 10^9 \times \frac{2 \times 5 \times 10^{-3} \times 10^{-12}}{3.14 \times (15 \times 10^{-2})^2}$$

$$= 1.27 \text{ k Vm}^{-1}$$

**34.(A)** Suppose the point charge is passing through origin at  $t = 0$

Now, the retarded time is given by,

$$r = |\vec{r} - \vec{u}(t_r)| = C(t - t_r)$$

where  $\vec{u}(t_r)$  gives the position of point charge at time and retarded time  $t_r$ . (i.e.

$$\vec{u}(t_r) = \vec{V}t_r \text{ and } \hat{r} = \frac{(\vec{r} - \vec{V}t_r)}{C(t - t_r)}$$

$$\text{Now, } r(C - \hat{r} \cdot \vec{V}) = C(t - t_r) \left[ C - \frac{(\vec{r} - \vec{V}t_r) \cdot \vec{V}}{C(t - t_r)} \right]$$

$$= C^2(t - t_r) - \vec{r} \cdot \vec{V} - V^2 t_r$$

$$\text{Therefore, } V = \frac{1}{4\pi\epsilon_0} \frac{qC}{(r C - \vec{r} \cdot \vec{V})}$$

[Lienard - Wiechert scalar potential]

$$= \frac{1}{4\pi\epsilon_0} \frac{qC}{(C^2 (t-t_r) - \vec{r} \cdot \vec{V} - V^2 t_r)}$$

**35.(A)** The fraction of electrons contributing because of the pauli's exclusion principle

$$\frac{KT}{\epsilon_f} = \frac{KT}{KT_f} = \frac{T}{T_f}$$

So the paramagnetic susceptibility  $\chi$  for a metal can be obtained by reducing its classical

value given by a factor of  $\frac{T}{T_f}$  so  $\chi_{\text{pauli}} = \frac{T}{T_f} \chi_{\text{classical}}$

**36.(C)** Let us denote by  $|\psi\rangle$  an eigenvector of  $\hat{p}$  with an eigenvalue  $\lambda$ , namely

$$\hat{p} |\psi\rangle = \lambda |\psi\rangle .$$

$$\text{Therefore , } (\hat{p})^2 |\psi\rangle = \hat{p} \hat{p} |\psi\rangle = \lambda^2 |\psi\rangle \quad (1)$$

Expanding  $|\psi\rangle$  in the (complete)  $|m_1, m_2\rangle$  basis , we have

$$|\psi\rangle = \sum_{m_1, m_2} \langle m_1, m_2 | \psi \rangle |m_1, m_2\rangle \quad (2)$$

However , by the definition of  $\hat{p}$

$$(\hat{p})^2 |m_1, m_2\rangle = |m_1, m_2\rangle , \text{ and}$$

$$\begin{aligned} \text{then } (\hat{p})^2 |\psi\rangle &= \sum_{m_1, m_2} \langle m_1, m_2 | \psi \rangle (\hat{p})^2 |m_1, m_2\rangle \\ &= |\psi\rangle \end{aligned} \quad (3)$$

Comparing (1) and (3) we find that  $\lambda^2 = 1$  and , as a result , the eigenvalues of  $\hat{p}$  must be  $\lambda = \pm 1$  .

**37.(B)** Let E be the energy of the particle and m its mass . The transmission coefficient in the semiclassical approximation is given by

$$T \approx \exp \left\{ -\frac{2}{\hbar} \int_{x_1}^{x_2} \sqrt{2m[V(x) - E]} dx \right\} \quad \dots(1)$$

where  $x_1$  and  $x_2$  are the turning points computed using the condition  $V(x) = E$ .

Hence,

$$x_1 = -a \sqrt{1 - \frac{E}{V_0}} \quad x_2 = +a \sqrt{1 - \frac{E}{V_0}} \quad \dots(2)$$

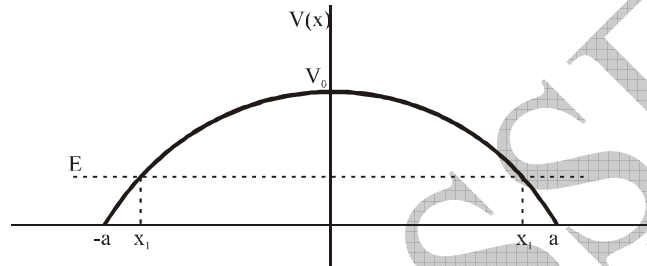

Thus ..(2) becomes

$$T = \exp \left[ -\frac{2}{\hbar} \int_{-a \sqrt{1 - \frac{E}{V_0}}}^{+a \sqrt{1 - \frac{E}{V_0}}} \sqrt{2m \left[ V_0 \left( 1 - \frac{x^2}{a^2} \right) - E \right]} dx \right] \quad \dots(3)$$

Computing the integral gives

$$T = \exp \left[ -\pi \sqrt{\frac{2m}{V_0}} \frac{a(V_0 - E)}{\hbar} \right] \quad \dots(4)$$

Note that the expression of T is valid if the exponent in (4) is large; that is ,

$$\pi \sqrt{\frac{2m}{V_0}} \frac{a(V_0 - E)}{\hbar} \gg 1 \quad \dots(5)$$

**38.(C)** We begin by writing the hamiltonian as

$$H = \frac{1}{2I_x} (L_x^2 + L_y^2) + \frac{1}{2I_z} L_z^2$$

$$L^2 = L_x^2 + L_y^2 + L_z^2 \Rightarrow L_x^2 + L_y^2 = L^2 - L_z^2$$

$$= \frac{1}{2I_x} (L^2 - L_z^2) + \frac{1}{2I_z} L_z^2$$

$$= \frac{L^2}{2I_x} + \left( \frac{1}{2I_z} - \frac{1}{2I_x} \right) L_z^2$$

where L is the total angular momentum. Recall that if A is an operator that has the eigenvalues  $\lambda_i (i=1,2, \dots, n)$  the eigenvalues of  $f(A)$  (where  $f(A)$  is a function of A) are  $f(\lambda_i)$ . Therefore the eigenvalues of the energy are

$$E_{lm} = \frac{\hbar^2}{2I_x} \ell(\ell+1) + \left( \frac{1}{2I_z} - \frac{1}{2I_x} \right) \hbar^2 m^2$$

**39.(A)** Consider the Legendre polynomial  $P_1(x) = x$ ; so  $\frac{d}{dx}(P_1(x)) = 1$ . Therefore, from

$$\text{equation } P_l^m(x) = (1-x^2)^{|m|/2} \frac{d^{|m|}}{dx^{|m|}} P_l(x) = P_l^{-m}(x) \quad \text{we have}$$

$$P_1^1(x) = P_1^1(x) = \sqrt{1-x^2}$$

Similarly,  $P_1^0(x) = x$ ; thus, using equation  $Y_l^m(\theta, \phi)$

$$= C_l^m P_l^m \cos \theta e^{im\phi}$$

we obtain

$$Y_1^1(\theta, \phi) = C_1^1 P_1^1(\cos \theta) e^{i\phi} = C_1^1 \sin \theta e^{i\phi}$$

$$\text{Also, } Y_1^{-1}(\theta, \phi) = C_1^{-1} \sin \theta e^{-i\phi} \quad Y_1^0(\theta, \phi) = C_1^0 \cos \theta$$

Using the normalization condition we arrive at

$$\int_0^{2\pi} d\phi \int_0^\pi (Y_l^m)^*(\theta, \phi) Y_l^m(\theta, \phi) \sin \theta d\theta = 1 \quad \Rightarrow \quad \int_0^{2\pi} d\phi \int_0^\pi (C_l^0)^2 \cos^2 \theta d\theta = 1$$

$$\text{or, } -2\pi (C_1^0)^2 \int_0^\pi \cos^2 \theta d(\cos \theta) = 1, \text{ that is, } C_1^0 = \sqrt{\frac{3}{4\pi}}. \text{ Similarly,}$$

$$C_1^1 = C_1^{-1} = \left( \int_0^{2\pi} d\phi \int_0^\pi \sin \theta e^{i\phi} \sin \theta e^{-i\phi} \sin \theta d\theta \right) = \left( 2\pi \int_0^\pi \sin^3 \theta d\theta \right)^{-2} = \sqrt{\frac{3}{8\pi}}$$

Finally, we have

$$Y_1^0(\theta, \phi) = \sqrt{\frac{3}{4\pi}} \cos \theta \quad Y_1^1(\theta, \phi) = \sqrt{\frac{3}{8\pi}} \sin \theta e^{i\phi} \quad Y_1^{-1}(\theta, \phi) = \sqrt{\frac{3}{8\pi}} \sin \theta e^{-i\phi}$$

**40.(D)** From Rodrigue formula we have

$$P_n(x) = \frac{1}{2^n n!} \frac{d^n}{dx^n} (x^2 - 1)^n$$

$$\begin{aligned} \int_{-1}^1 x^2 P_5(x) dx &= \int_{-1}^1 x^2 \frac{1}{2^5 5!} \frac{d^5}{dx^5} (x^2 - 1)^5 dx \\ &= \frac{1}{2^5 5!} \left[ \left\{ x^2 \frac{d^4}{dx^4} (x^2 - 1)^5 \right\}_{-1}^{+1} - \int_{-1}^1 2x \frac{d^4}{dx^4} (x^2 - 1)^5 dx \right] \\ &= \frac{1}{2^5 5!} \left[ 0 - \left\{ 2x \frac{d^3}{dx^3} (x^2 - 1)^5 \right\}_{-1}^{+1} + \int_{-1}^1 2 \cdot 1 \frac{d^3}{dx^3} (x^2 - 1)^5 dx \right] \\ &= \frac{1}{2^5 5!} 2 \left[ 2x \frac{d^2}{dx^2} (x^2 - 1)^5 \right]_{-1}^{+1} \\ &= 0 \end{aligned}$$

41.(A) This equation is called  
Bromwich integral

$$F(t) = \frac{1}{2\pi i} \int_{c-i\infty}^{c+i\infty} f(s) e^{st} ds$$

42.(A) The function  $e^{2zx - z^2} = e\{x^2 - (z-x)^2\}$  generates all the Hermite polynomials and hence it is called the generating function of hermite polynomial .

43.(D) The distance of closest approach by using the concept that at the point

$$K.E = P.E$$

$$\text{So } \frac{1}{2} mV^2 = \frac{z_1 z_2 e^2}{4\pi\epsilon_0 r} \text{ or } r = \frac{2z_1 z_2 e^2}{4\pi\epsilon_0 MV^2}$$

Put the values,

$$Z_1 = 79, Z_2 = 1, K \cdot E = 3 \text{ MeV}$$

$$\begin{aligned} \text{So } r &= \frac{2 \times 79 \times 1 \times (1.6 \times 10^{-19})^2 \times 9 \times 10^9}{1.5 \times 1.6 \times 10^{-13}} \\ &= 1.5 \times 10^{-13} \text{ m} \end{aligned}$$

**44.(B)** We know that  $R = R_0 A^{1/3}$

So, radius of the gold nucleus is

$$R = 1.2 \times 10^{-15} \text{ m} \times (197)^{1/3}$$

$$= 6.98 \times 10^{-15} \text{ m}$$

Also, the radius of the first Bohr orbit for gold nuclei is  $\frac{a_0}{Z}$  where  $a_0 = 5.292 \times 10^{-11} \text{ m}$

$$\text{So } r = \frac{5.292 \times 10^{-11}}{79} = 6.69 \times 10^{-13} \text{ m}$$

$$\text{So } \frac{r}{R} = \frac{6.69 \times 10^{-13}}{6.98 \times 10^{-15}} = 96 \text{ times}$$

**45.(A)** The formula for Larmor frequency of a proton is

$$\nu_L = \frac{2\mu_p B}{h} \text{ where } \mu_N \text{ nuclear magneton}$$

$$= 3.152 \times 10^{-8} \text{ eV/T}$$

$h$  is Planck's constant

$$= 4.137 \times 10^{-15} \text{ eV} \cdot \text{s}$$

and  $\mu_p = \pm 2.793 \mu_N$

$$\text{So } \nu_L = \frac{2 \times 2.793 \times 3.152 \times 10^{-8} \text{ eV/T} \times 4 \times 10^{-5} \text{ T}}{4.136 \times 10^{-15} \text{ eV} \cdot \text{s}}$$

$$= 1.70 \text{ kHz}$$

**46.(B)** The bias current through the compensating diodes is:

$$I_{\text{bias}} = \frac{20 \text{ V} - 1.4 \text{ V}}{2(3.9 \text{ k}\Omega)} = 2.38 \text{ mA}$$

This is the value of the quiescent collector current assuming that the compensating diodes match the emitter diodes.

The collector saturation current is :

$$I_{C(\text{sat})} = \frac{V_{\text{CEQ}}}{R_L} = \frac{10 \text{ V}}{10 \Omega} = 1 \text{ A}$$



the average value of the half-wave collector current is :

$$I_{av} = \frac{I_{C(sat)}}{\pi} = \frac{1A}{\pi} = 0.318 A$$

The total current drain is:

$$I_{dc} = 2.38 mA + 0.318 A = 0.32 A$$

The dc input power is :

$$P_{dc} = (20 V) (0.32 A) = 6.4 W$$

The maximum ac output power is :

$$P_{out(max)} = \frac{MPP^2}{8R_L} = \frac{(20 V)^2}{8(10 \Omega)} = 5W$$

The efficiency of the stage is

$$\eta = \frac{P_{out}}{P_{dc}} \times 100\% = \frac{5W}{6.4W} \times 100\% = 78.1\%$$

**47.(C)** This is based upon the meson theory of nuclear forces which assumes that there is a virtual exchange of pions between the nucleons.

The emitted pion will move nearly with the velocity of light so, energy of pion is

$$E = mc^2 = 271 \times 9.1 \times 10^{-31} \times (3 \times 10^8)^2$$

According to uncertainty principle

$$\Delta E \Delta t = \frac{h}{2\pi} \quad \text{or} \quad \Delta t = \frac{h}{2\pi \Delta E} = \frac{h}{2\pi mc^2}$$

In this time the pions must be absorbed , so as to conserve energy.

Suppose that in this time  $\Delta t$  , it covers r distance, so  $r = c\Delta t$

$$\text{or } r = \frac{3 \times 10^8 \times 6.62 \times 10^{-34}}{2 \times 3.14 \times 271 \times 9.1 \times 10^{-31} \times (3 \times 10^8)^2}$$

$$= 1.42 \times 10^{-15} = 1.42 \text{ Fermi}$$

So, this is the range of nuclear forces.

**48.(A)** We can use the radial wave function equation for the ground state of deuterium  
i.e.

$$\frac{d^2u}{dr^2} + \frac{M}{\hbar^2} [V_0 - B] u = 0 \text{ for } r < b$$

$$\text{and } \frac{d^2u}{dr^2} + \frac{M}{\hbar^2} [-B] u = 0 \text{ for } r > b$$

where B is the binding energy, we can also write them as,

$$\frac{d^2u}{dr^2} + k^2 u = 0 \text{ for } r < b$$

$$\text{and } \frac{d^2u}{dr^2} + \alpha^2 u = 0 \text{ for } r > b$$

$$\text{where } k^2 = \frac{M}{\hbar^2} [V_0 - B] \text{ and } \alpha^2 = \frac{MB}{\hbar^2}$$

$$\text{Therefore } \frac{k}{\alpha} = \sqrt{\frac{V_0 - B}{B}},$$

$$\text{Since, } b = \pi / 2K \text{ and } R = 1/\alpha$$

$$\text{So } \frac{\pi/2b}{1/R} = \sqrt{\frac{V_0 - B}{B}} \text{ or } R = \frac{2b}{\pi} \sqrt{\frac{V_0 - B}{B}}$$

As  $B \ll V_0$ , we can approximate  $V_0 - B = V_0$ .

$$\text{So } R = \frac{2b V_0^{1/2}}{\pi} B^{1/2}.$$

**49.(A)** We will use the equation  $R = \lambda N$

For this we have to calculate  $\lambda$

$$\text{So } \lambda = \frac{0.693}{1620 \times 365 \times 24 \times 60 \times 60}$$

Now 226 kg of Ra contains  $6.025 \times 10^{26}$  atoms.

$$\text{So, } M \text{ kg of Ra contains } = \frac{6.025 \times 10^{26}}{226} \times M = N$$

Putting these values we get ,

$$3.7 \times 10^{10} = \frac{6.025 \times 10^{26} \times M}{226} \times 1.36 \times 10^{-11}$$

$$\begin{aligned} \text{or } M &= \frac{226 \times 3.7 \times 10^{10}}{6.025 \times 10^{26} \times 1.36 \times 10^{-11}} \\ &= 1.02 \times 10^{-3} \text{ kg} \end{aligned}$$

**50.(B)** Lorentz factor is required to find out the half life of the kaons in laboratory frame of reference as

$$\tau = \gamma T_{1/2} \quad (1)$$

We know that  $K \cdot E = mc^2 (\gamma - 1)$

$$\begin{aligned} \text{or } \gamma &= \frac{K \cdot E}{mc^2} + 1 = \frac{6000 \text{ MeV}}{494 \text{ MeV}} + 1 \\ &= 12.15 + 1 = 13.1 \end{aligned}$$

Putting in (1), we get

$$\tau = 13.15 \times 8.6 \times 10^{-9} = 11.3 \times 10^{-8} \text{ s}$$

So, the distance covered by it in this time travelling with speed of light is

$$S = 3 \times 10^8 \times 11.3 \times 10^{-8} = 33.9 \text{ m}$$

So, we can expect that kaon should remain half of the initial number on travelling S distance in the lab frame. So, for the total distance of 150 m the number of kaons in the beam drops to

$$\left(\frac{1}{2}\right)^{\left(\frac{150}{33.9}\right)} = .047 \text{ or } 4.7\%$$

So, it drops to 4.7% of the initial value due to decay alone