

CSIR UGC NET CHEMICAL SCIENCE – MOCK TEST PAPER

CSIR UGC NET CHEMICAL SCIENCE – MOCK TEST PAPER

- This paper contains 75 Multiple Choice Questions
- Part A 15, part B 35 and part C 25 Each question in Part 'A' carries two marks
- Part 'B' carries 2 marks
- Part 'C' carries 4 marks respectively
- There will be negative marking @ 25% for each wrong answer.
- Pattern of questions : MCQs
- Total marks : 200
- Duration of test : 3 Hours

PART A (1-15)

1. Average yield of a product in different years is shown in the histogram. If the vertical bars indicate variability during the year, then during which year was the percent variability over the average of that year the least?

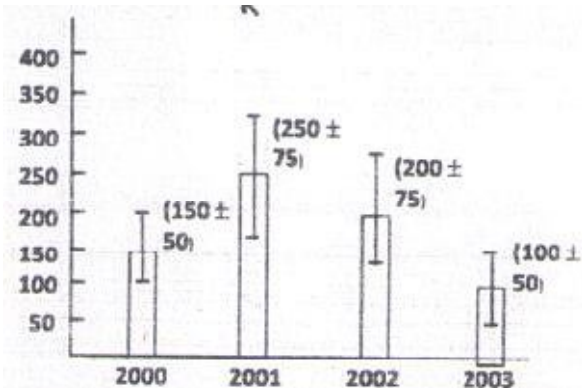

- (1) 2000
 (2) 2001
 (3) 2002
 (4) 2003
2. A rectangular sheet ABCD is folded in such a way that vertex A meets vertex C, thereby forming a line PQ. Assuming $AB = 3$ and $BC = 4$, find PQ. Note that $AP = PC$ and $AQ = QC$.

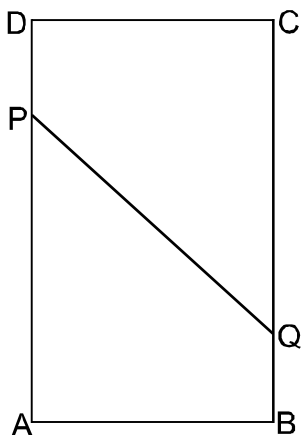

(1) $\frac{13}{4}$

(2) $\frac{15}{4}$

$\frac{17}{4}$

(3) $\frac{4}{4}$

$\frac{19}{4}$

(4) $\frac{4}{4}$

3. Density of a rice grain is 1.5 g/cc and bulk density of rice heap is 0.80 g/cc. If a 1 litre container is completely filled with rice, what will be the approximate volume of pore space in the container?
- (1) 350 cc
(2) 465 cc
(3) 550 cc
(4) 665 cc
4. A peacock perched on the top of a 12 m high tree spots a snake moving towards its hole at the base of the tree from a distance equal to thrice the height of the tree. The peacock flies towards the snake in a straight line and they both move at the same speed. At what distance from the base of the tree will the peacock catch the snake?
- (1) 16 m
(2) 18 m
(3) 14 m
(4) 12 m
5. The map given below shows a meandering river following a semi-circular path, along which two villages are located at A and B. The distance between A and B along the east-west direction in the map is 7 cm. What is the length of the river between A and B in the ground?

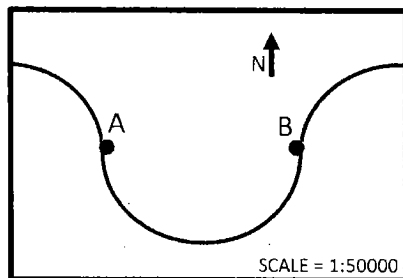

- (1) 1.1 km
(2) 3.5 km

- (3) 5.5 km
(4) 11.0 km
6. How many nine-digit positive integers are there, the sum of squares of whose digits is 2?
- (1) 8
(2) 9
(3) 10
(4) 11
7. A bird leaves its nest and flies away. Its distance x from the nest is plotted as a function of time t . Which of the following plots cannot be right?

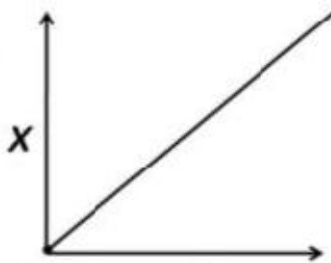

(1) nest t

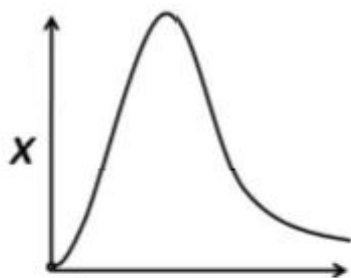

(2) nest t

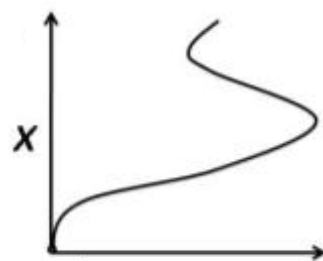

(3) nest t

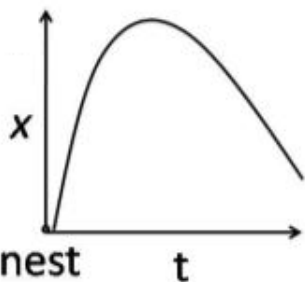

(4)

8. What is the next number in the following sequence?

39, 42, 46, 50, ...

(1) 52

(2) 53

(3) 54

(D) 55

9. A solid cylinder of basal area A was held dipped in water in a cylindrical vessel of basal area $2A$ vertically such that a length h of the cylinder is immersed. The lower tip of the cylinder is at a height h from the water in the vessel when the cylinder is taken out?

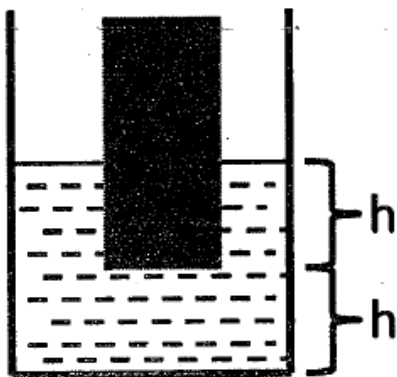

(1) $2h$

(2) $\frac{3}{2}h$

(3) $\frac{4}{3}h$

(4) $\frac{5}{4}h$

10. How many pairs of positive integers have gcd 20 and lcm 600?
(gcd = greatest common divisor; lcm = least common multiple)
- (1) 4
(2) 0
(3) 1
(4) 7
11. Consider a right-angled triangle ABC where $AB = AC = 3$. A rectangle APOQ is drawn inside it, as shown, such that the height of the rectangle is twice its width. The rectangle is moved horizontally by a distance 0.2 as shown schematically in the diagram (not to scale).
- $\frac{\text{Area of } \triangle ABC}{\text{Area of } \triangle OST}$?
- What is the value of the ratio $\frac{\text{Area of } \triangle ABC}{\text{Area of } \triangle OST}$?
- (1) 625
(2) 400
(3) 225
(4) 125
12. A shopkeeper purchases a product for Rs. 100 and sells it making a profit of 10%. The customer resells it to the same shopkeeper incurring a loss of 10%. In these dealings the shopkeeper makes
- (1) no profit, no loss
(2) Rs. 11
(3) Re. 1
(4) Rs. 20
13. In 450 g of pure coffee powder 50 g of chicory is added. A person buys 100 g of this mixture and adds 5 g of chicory to that. What would be the rounded-off percentage of chicory in this final mixture?
- (1) 10
(2) 5
(3) 14
(4) 15
14. Following table provides figures (in rupees) on annual expenditure of a firm for two years - 2010 and 2011.

Category	2010	2011
Raw material	5200	6240
Power & fuel	7000	9450
Salary & wages	9000	12600
Plant & machinery	20000	25000
Advertising	15000	19500
Research & Development	22000	26400

In 2011, which of the following two categories have registered increase by same percentage?

- (1) Raw material and Salary & wages
- (2) Salary & wages and Advertising
- (3) Power & fuel and Advertising
- (4) Raw material and Research & Development

15. Find the missing sequence in the letter series.

B, FH, LNP,-----.

- (1) SUMY
- (2) TUVW
- (3) TVXZ
- (4) TWXZ

PART B(16-40)

16. The order of 1st and 2nd I.E. for Be & B is —

- (1) $(IE)_1$ — B > Be, $(IE)_2$ — Be > Be
- (2) $(IE)_1$ — Be > B, $(IE)_2$ — B > Be

- (3) In $(IE)_1$ & $(IE)_2$ $Be > B$
- (4) In $(IE)_1$ & $(IE)_2$ $B > Be$
17. The order of \angle FSF bond angle for SF_2 , SOF_2 , $S(CH_2)F_2$
- (1) $SF_2 > SOF_2 > S(CH_2)F_2$
- (2) $S(CH_2)F_2 > SOF_2 > SF_2$
- (3) $SOF_2 > SF_2 > S(CH_2)F_2$
- (4) $SOF_2 > S(CH_2)F_2 > SF_2$
18. Full form of SQUIDs is —
- (1) Supra Quantity Interference Devices.
- (2) Semiconducting quantity impurity Devices.
- (3) Semiconducting Quantum intrinsic Devices.
- (4) Superconducting Quantum Interference Devices.
19. According to crystal field theory, Ni^{2+} can have two unpaired electrons in
- (1) octahedral geometry only
- (2) square-planar geometry only
- (3) tetrahedral geometry only
- (4) both octahedral and tetrahedral geometry
20. In the following four elements, the ionization potential of which one is the highest ?
- (1) Oxygen
- (2) Argon
- (3) Barium
- (4) Cesium
21. The hybridization of P in PO_4^{3-} is the same as that of —
- (1) S in SO_3
- (2) N in NO_3^-
- (3) I in ICl_2^+

- (4) I in ICl_4^+
22. In N_2O , the bond order between N – N is
- (1) 2
(2) 3
(3) 1
(4) 2.5
23. The possible values of total angular momentum resulting from the additions of angular momentum with quantum numbers.
- $j_1 = 2, j_2 = 4$
- (1) 6
(2) 5
(3) 4
(4) 2
24. The change in oxidation number of Cr, when CrO_2Cl_2 is dissolved in NaOH is —
- (1) +6 → +4
(2) +4 → +6
(3) +6 → +3
(4) No change
25. Position of the following ligands in the spectrochemical series is —
- (a) CN^- (b) NH_3 (c) N_3^-
- (1) $a > c > b$
(2) $c > b > a$
(3) $a > b > c$
(4) $b > a > c$
26. The order of elution of lanthanide ions solution containing La^{3+} , Ga^{3+} , Lu^{3+} by ion exchange method is
- (1) $\text{La}^{3+} > \text{Ga}^{3+} > \text{Lu}^{3+}$

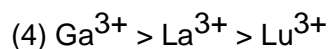
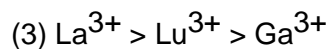

27. The product formed in the following reaction is —

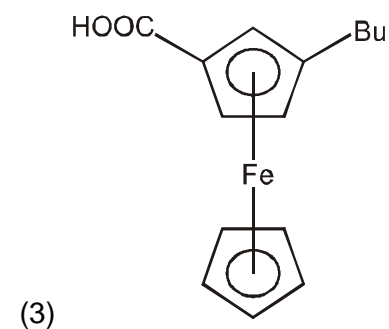
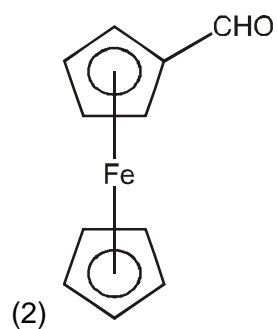
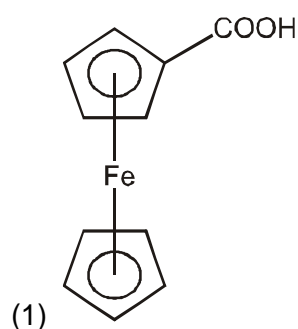
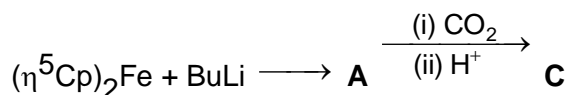

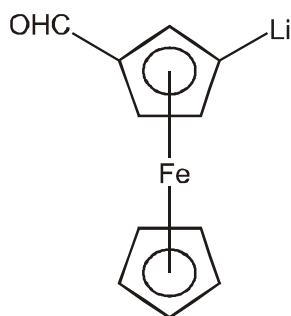

(4)

28. $[\text{Ni}(\text{CN})_4]^{2-}$ and $[\text{NiCl}_4]^{2-}$ complex ions are
- (1) both diamagnetic
 - (2) both paramagnetic
 - (3) diamagnetic and paramagnetic respectively
 - (4) antiferromagnetic and diamagnetic respectively

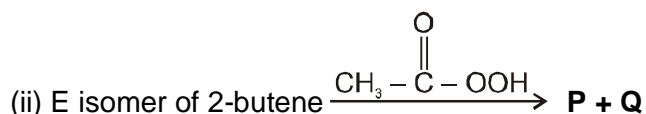

X and Y & P and Q are

- (1) X and Y are mesomers & P and Q are Homomers.
 - (2) X and Y are mesomers & P and Q are Enantiomers.
 - (3) X and Y are Enantiomers & P and Q are mesomers.
 - (4) X and Y are Enantiomers & P and Q are Homomers.
30. The intermediate Y and the product Z in the following reaction are respectively —

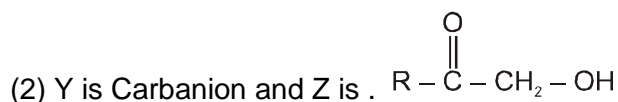
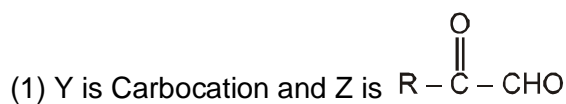
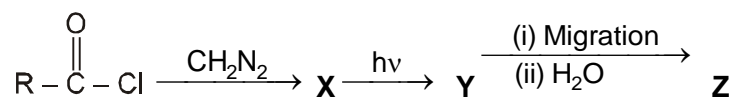

(3) Y is Carbene and Z is $R - CH_2 - COOH$.

(4) Y is Nitrene and Z is $R - \overset{O}{\parallel}C - NH - CH_3$

31. Choose the correct statement about the following compounds,

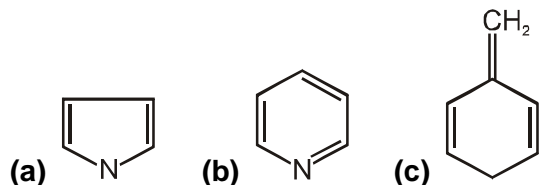

- (1) All are aromatic.
 (2) a, b are aromatic, c is non aromatic.
 (3) a is aromatic, b & c are non aromatic.
 (4) b, c are aromatic, a is non aromatic.

32. The correct statement for the following reaction is —

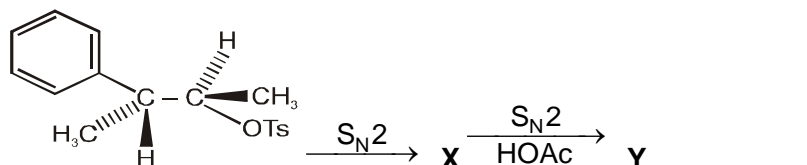

(1) X is Classical Carbocation and Y is .

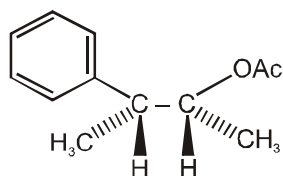

(2) X is Classical Carbocation and Y is

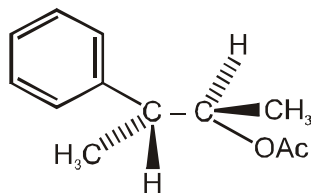

(3) X is non-classical Carbocation (Phenonium ion) and Y is

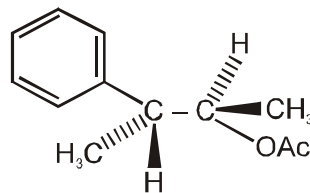

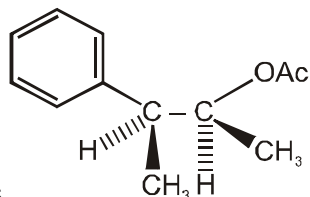

(4) X is non-classical Carbocation (Phenonium ion) and Y is

33. Glucose $\xrightarrow[2. P/HI]{1. HCN/H_3O^+}$ A, A is –

- (1) n-heptanoic acid
- (2) 2-methyl hexanoic acid
- (3) n-heptane
- (4) 2-methyl hexane

34. The product formed in the following reaction is —

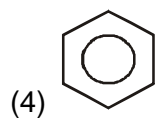
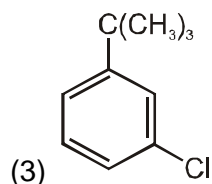
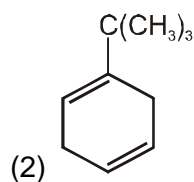
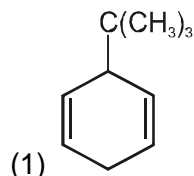
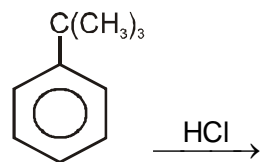

35. The final product formed in the following reaction is —

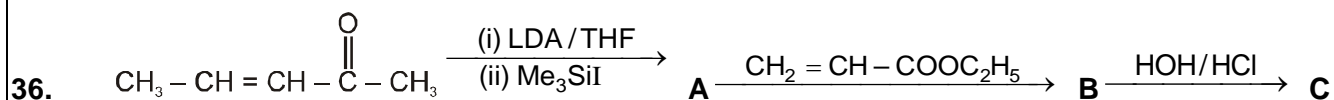
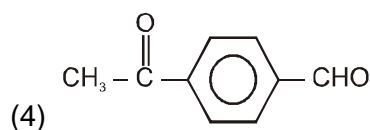
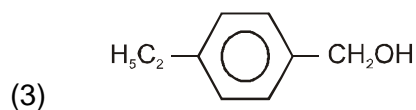
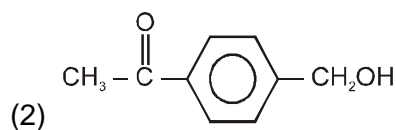
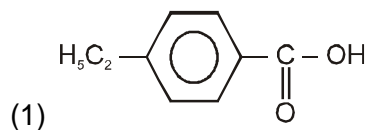
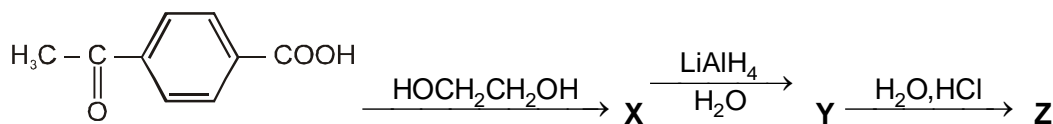

The end product C is —

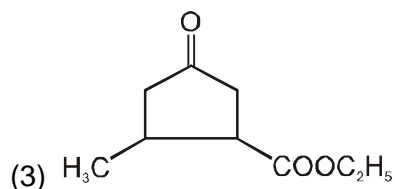
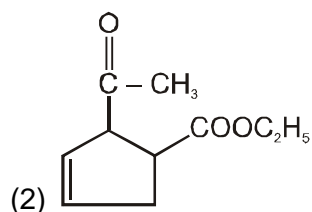
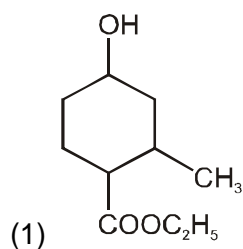

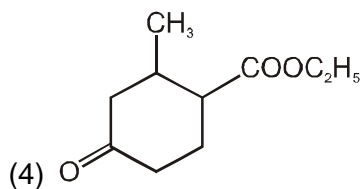

37. The suitable reagents for the following conversion are —

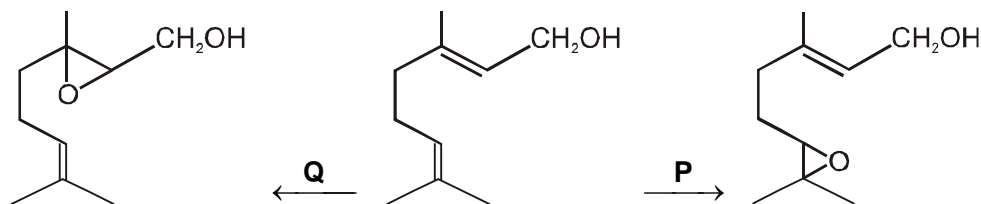

- (1) **P** = mCPBA, **Q** = t-Butyl hydroperoxide
 (2) **P** = t-Butyl hydroperoxide, **Q** = mCPBA
 (3) **P** = mCPBA, **Q** = H₂O₂
 (4) **P** = H₂O₂, **Q** = mCPBA

38. The product formed in the following rearrangement reaction is —

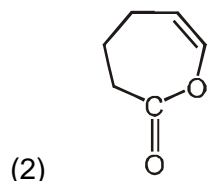
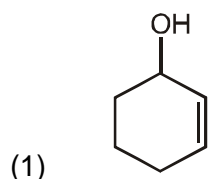
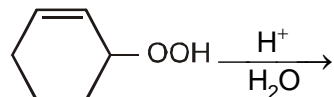

- (3) OHC - CH₂ - CH₂ - CH₂ - CH₂CHO

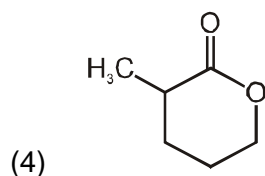

39. The processes involved in the following interconversion are —

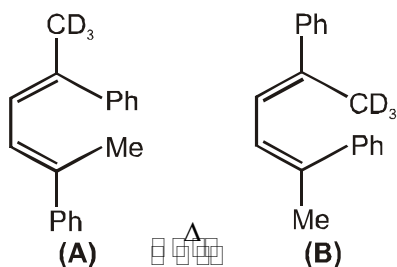

- (1) Photochemical conrotation followed by thermal conrotation,
 (2) Thermal conrotation followed by Photochemical conrotation,
 (3) Two continuous thermal conrotation
 (4) Thermal disrotation followed by Photochemical conrotation.
40. One litre of gas A at two atmospheric pressure and two litres of gas B at three atmospheric pressure are mixed in a four -litre flask to form an ideal gas mixture. What will be the final pressure of the gaseous mixture if the gases initially and finally where at the same temperature?
- (1) 1.0 atmosphere
 (2) 1.5 atmosphere
 (3) 2.0 atmosphere
 (4) 2.5 atmosphere
41. The major product formed in the reaction given below is

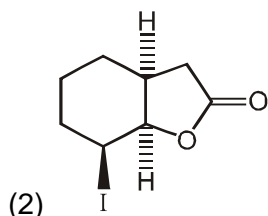
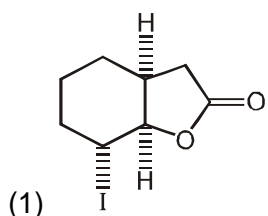
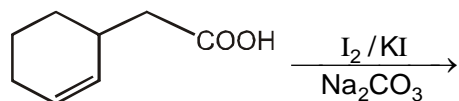

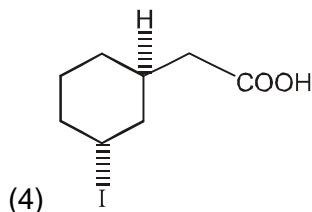
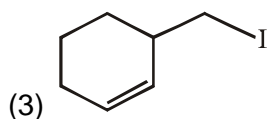

42. Given that Plank's constant = 6.6×10^{-27} erg - second, velocity of light = 3×10^{10} cm/s, the energy of a photon of wavelength 3000 Å will be
- (1) 6.6×10^{-12} erg
 - (2) 13.2×10^{-12} erg
 - (3) 3.3×10^{-12} erg
 - (4) 4.95×10^{-12} erg
43. 60 grams of gaseous C_2H_6 are mixed with 28 grams of gaseous carbon monoxide. The pressure of the resulting gaseous mixture is 3 atm. The partial pressure of C_2H_6 in the mixture is
- (1) 3 atm
 - (2) 1.5 atm
 - (3) 1 atm
 - (4) 2 atm
44. The hydrogen ion concentration in mol dm^{-3} in 0.2 M ethanoic acid ($K_a = 2 \times 10^{-5} \text{ mol dm}^{-3}$) is approximately
- (1) 2×10^{-2}
 - (2) 2×10^{-3}
 - (3) 2×10^{-4}
 - (4) 2×10^{-5}
45. **Statement** : Solid carbon dioxide is called as dry ice.
Reason : CO_2 sublimes when kept in open atmosphere.

Assertion : Triple point of CO_2 lies above one atmospheres.

- (1) All correct
- (2) statement incorrect
- (3) Reason incorrect
- (4) Assertion incorrect

46. The following data pertains to a reaction between A and B :

S.No.	[A], mol./ l^{-1}	[B], mol./ l^{-1}	Rate , mol./ l^{-1} , t^{-1}
I.	1×10^{-2}	2×10^{-2}	2×10^{-4}
II.	2×10^{-2}	2×10^{-2}	4×10^{-4}
III.	2×10^{-2}	4×10^{-2}	8×10^{-4}

Which of the following inference (s) can be drawn from the above data ?

Codes : I. Rate constant of the reaction is 10^{-4}

II. Rate law of the reaction is $k [A] [B]$.

III. Rate of reaction increases four times on doubling the concentration of both reactants.

Select the correct answer using the codes given below :

- (1) I, II and III
 - (2) I and II
 - (3) II and III
 - (4) III alone
47. If the pressure of hydrogen gas is increased from 1 atm to 100 atm, keeping the hydrogen ion concentration constant 1 M, the voltage of the hydrogen half cell as 25°C will be
- (1) 0.059 V
 - (2) 0.59 V
 - (3) 0.0295 V
 - (4) 0.118 V
48. The Nernst equation,
- $$E = E^\circ - (RT/nF)nQ$$
- indicates that the equilibrium constant H_c will be equal to Q when
- (1) $E = E^\circ$

- (2) $RT/nF = 1$
(3) $E = \text{zero}$
(4) $E^\circ = 1$
49. The number of possible isomers for $[\text{Ru}(\text{bpy})_2\text{Cl}_2]$ is (bpy = 2,2'-bipyridine)
- (1) 2
(2) 3
(3) 4
(4) 5
50. The highest occupied MO in N_2 and O_2^+ respectively are (take x-axis as internuclear axis)
- (1) $\sigma 2p_x, \pi^* 2p_y$
(2) $\pi 2p_y, \pi 2p_z$
(3) $\sigma^* 2p_x, \sigma 2p_x$
(4) $\pi^* 2p_y, \pi^* 2p_z$
- Part-C (51-75)**
51. What is correct statement about cytochrome C & myoglobin ?
- (1) Both proteins have Heme group.
(2) Cytochrome C is a redox protein while myoglobin is an oxygen storage protein.
(3) (1) & (2) both.
(4) Cytochrome C has only Cu centre and myoglobin has only Fe centre.
52. The appropriate symmetry point groups for a free SO_4^{2-} and a SO_4^{2-} ion coordinated to a metal in a linear fashion through one O donor atom respectively are-
- (1) T_d, C_{4v}
(2) C_{2v}, C_{3v}
(3) T_d, C_{3v}
(4) C_{3v}, C_{4n}

53. What is correct statement for twisting mode of vibration of N_2O_4 (planar) ?
- (1) IR active and Raman inactive
 - (2) IR inactive and Raman active
 - (3) IR and Raman active
 - (4) IR and Raman inactive
54. **Statement-I** — Fe^{2+} and Fe^{3+} have different chemical shifts in massbauer spectroscopy.
- Statement-II** — Iron is in low spin state when oxygenated and in high spin state when de-oxygenated.
- (1) Statement-I and II are correct. Statement-II is correct explanation for statement-I.
 - (2) Statement-I and II are correct. Statement-II is not correct explanation for statement-I.
 - (3) Statement-I is correct and statement-II is incorrect.
 - (4) Both are incorrect.
55. The point group of HF is —
- (1) C_{2v}
 - (2) $C_{\infty v}$
 - (3) D_{2v}
 - (4) $D_{\infty h}$
56. No. of signals are obtained for $Ti(C_5H_5)_4$ in NMR spectra at low temperature are -
- (1) 1
 - (2) 4
 - (3) 2
 - (4) 10
57. Given $Ag^+ + e \rightarrow Ag, E_0 = 0.50 V$
- $$Cu^{2+} + 2e \rightarrow Cu, E_0 = 0.34 V$$
- A 100 ml solution is 1080 mg with respect to Ag^+ and 635 mg with respect to Cu^{2+} . If 0.1 mg Ag^+ left in the

solution is considered to be the complete deposition of Ag^+ , the cathode potential, so that no copper is deposited during the process, is —

- (1) 0.16 V
- (2) 0.84 V
- (3) 0.31 V
- (4) -0.16 V

58. Calculate the mass number and the atomic number for Bi in the following disintegration series.

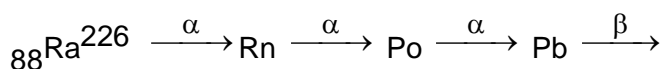

- (1) ${}_{82}\text{Bi}^{214}$
- (2) ${}_{81}\text{Bi}^{216}$
- (3) ${}_{80}\text{Bi}^{216}$
- (4) ${}_{83}\text{Bi}^{214}$

59. In the EI mass spectrum of compound $\text{C}_6\text{H}_{12}\text{O}$ an intense peak at m/z 58 is observed.

- (1) 1-Hexanal
- (2) 2-Hexanone
- (3) 3-Hexanone
- (4) 1-Hexanone

60. One more hexose gives the same aldaric acid on oxidation as does D-glucose. That can be,

- (1) L-glucose
- (2) Mannose
- (3) Galactose
- (4) L-Gulose

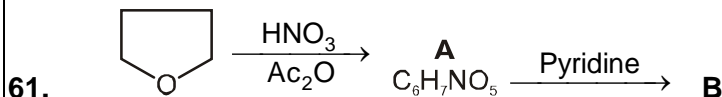

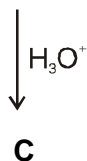

B & C are —

- (1) **B** = $\text{HOC} - \text{CH} = \text{CH} - \text{CHO}$, **C** = $\text{HOOC} - \text{CH} = \text{CH} - \text{COOH}$
 (2) **B** = $\text{NO}_2 - \text{CH}_2 - \text{CH} = \text{CH} - \text{CHO}$, **C** = $\text{CHO} - \text{CH} = \text{CH} - \text{CHO}$

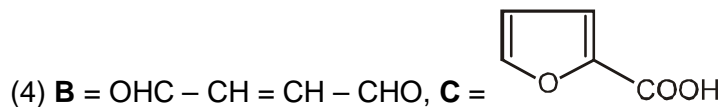
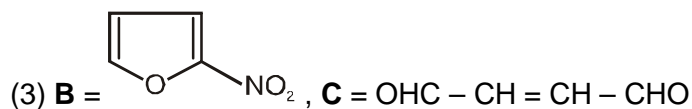

62. Match List-I with List-II.

List-I

- A. Hygrine
 B. Coniine
 C. Gramine

List-II

- (i) Indole
 (ii) Quinoline
 (iii) Piperidine
 (iv) Pyrrolidine

- (1) A-(ii), B-(iii), C-(iv)
 (2) A-(i), B-(ii), C-(iii)
 (3) A-(iii), B-(i), C-(ii)
 (4) A-(iv), B-(iii), C-(i)

63. The end product formed in the following reaction is —



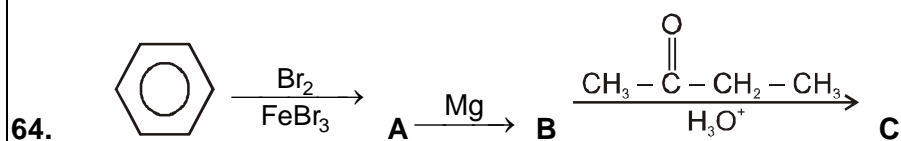
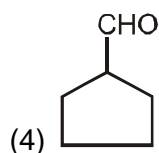
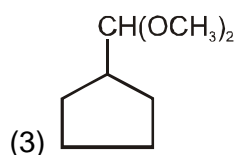
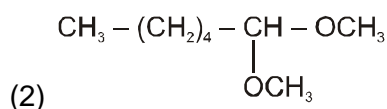
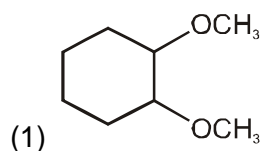

In the above reaction C is —

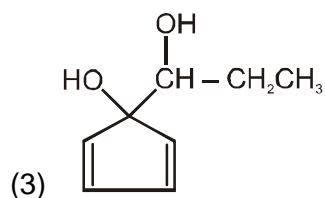
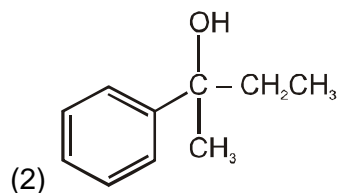
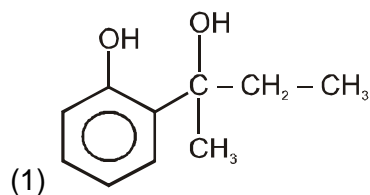

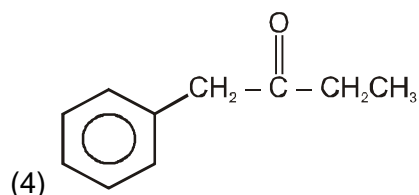

65. The product B in the following reaction is —

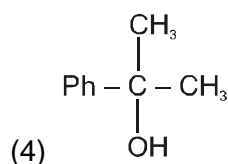
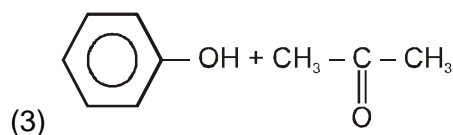
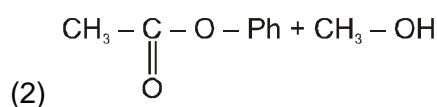
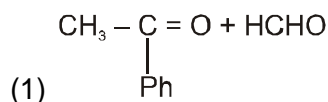
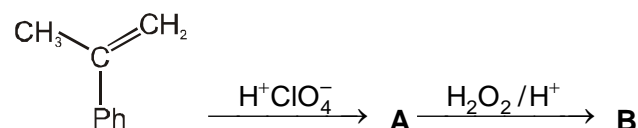

66. Match List-I with List-II.

List-I

List-II

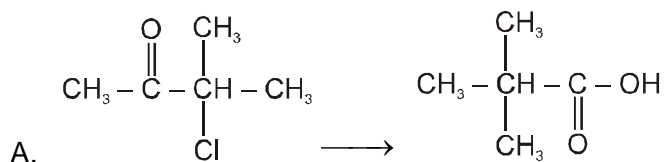

(i) Benzil-Benzilic Acid Rearrangement



(ii) Favorskii Reaction

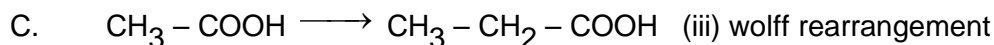

(iv) Benzoin Condensation

- (1) A-(ii), B-(i), C-(iv)
- (2) A-(iii), B-(ii), C-(i)
- (3) A-(iii), B-(i), C-(iv)
- (4) A-(ii), B-(iv), C-(iii)

67. For a given nuclear fission reaction of ^{235}U

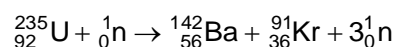

the amount of energy (in kJ/mol) released during this process is (given $^{235}\text{U} = 235.0439$ amu, $^{142}\text{Ba} = 141.9164$ amu, $^{91}\text{Kr} = 90.9234$ amu, neutron = 1.00866 amu)

- (1) 3.12×10^{12}
 - (2) 2.8×10^{11}
 - (3) 1.0×10^9
 - (4) 1.68×10^{10}
68. A particle X moving with a certain velocity has a debroglie wave length of 1 \AA . If particle Y has a mass of 25% that of X and velocity 75% that of X, debrogies wave length of Y will be:-
- (1) 3 \AA
 - (2) 5.33 \AA
 - (3) 6.88 \AA
 - (4) 48 \AA
69. What is not the allowed wavelength for a particle in a box ?
- (1) $2L$
 - (2) L
 - (3) $\frac{2}{3} L$
 - (4) $\frac{3}{2} L$
70. The decomposition of gaseous acetaldehyde at T(K) follows second order kinetics. The half-life of this reaction is 400 s when the initial pressure is 250 Torr. What will be the rate constant (in $\text{Torr}^{-1} \text{ s}^{-1}$) and

half-life (in s) respectively, if the initial pressure of the acetaldehyde is 200 Torr at the same temperature?

- (1) 10^5 and 500
- (2) 10^{-5} and 400
- (3) 10^{-4} and 400
- (4) 10^{-5} and 500

71. The J_{\max} for a rigid diatomic molecule for which at 300 K is; if the rotational constant is 1.566 cm^{-1} .

- (1) 1.5
- (2) 2
- (3) 11.5
- (4) 8

72. According to Graham's law, at a given temperature, the rate of diffusion $\frac{r_A}{r_B}$ of gasses A and B is given by

(1) $\left(\frac{P_A}{P_B}\right)\left(\frac{M_A}{M_B}\right)^{\frac{1}{2}}$

(2) $\left(\frac{M_A}{M_B}\right)\left(\frac{P_A}{P_B}\right)^{\frac{1}{2}}$

(3) $\left(\frac{P_A}{P_B}\right)\left(\frac{M_B}{M_A}\right)^{\frac{1}{2}}$

(4) $\left(\frac{M_A}{M_B}\right)\left(\frac{P_B}{P_A}\right)^{\frac{1}{2}}$

73. X ml of H_2 gas effuses through a hole in container in 5 seconds. The time taken for the effusion of the same volume of the gas specified below under identical conditions is:-

- (1) 10 s : He
- (2) 20 s : O_2
- (3) 25 s : CO
- (4) 55 s : CO_2

74. If the equilibrium constants for the reactions 1 and 2



are K_1 and K_2 , the equilibrium constant for the reaction $\text{CH}_4\text{(g)} + 2\text{H}_2\text{O(g)} \rightleftharpoons \text{CO}_2\text{(g)} + 4\text{H}_2\text{(g)}$ is

(1) $K_1 + K_2$

(2) $K_1 - K_2$

(3) $K_1 K_2$

(4) $\frac{K_1}{K_2}$

75. Observe the following aqueous solutions of same compound. All the measurements are made at same wavelength and same temperature.

Solution A — The transmittance of 0.1 mol dm^{-3} using 1 cm cell is 0.5.

Solution B — The optical density of 0.5 mol dm^{-3} is measured using 1 mm cell.

Solution C — The transmittance of this solution is 0.1.

The optical density of these solutions follow the order — ($\log 20 = 1.3010$; $\log 30 = 1.4771$; $\log 50 = 1.6990$)

(1) $A > B > C$

(2) $B > C > A$

(3) $B > A > C$

(4) $C > A > B$

ANSWER KEY

Question	1	2	3	4	5	6	7	8	9	10	11	12	13	14	15
Answer	2	2	2	1	3	1	3	2	2	1	3	2	3	4	3
Question	16	17	18	19	20	21	22	23	24	25	26	27	28	29	30
Answer	2	4	4	4	2	3	4	2	4	3	2	1	4	2	3
Question	31	32	33	34	35	36	37	38	39	40	41	42	43	44	45
Answer	2	3	1	4	2	4	2	3	3	3	3	1	4	2	1
Question	46	47	48	49	50	51	52	53	54	55	56	57	58	59	60
Answer	3	1	3	4	1	3	3	4	2	2	3	3	4	2	4
Question	61	62	63	64	65	66	67	68	69	70	71	72	73	74	75
Answer	3	4	3	2	3	4	4	2	4	4	4	3	2	2	3

HINTS AND SOLUTIONS

1.(2) The percentage of variability over the average of that year

$$\text{year 2000} \rightarrow \left(\frac{50}{150} \times 100 \right) = 33.33\%$$

$$\text{year 2001} \rightarrow \left(\frac{75}{250} \times 100 \right) = 30\%$$

$$\text{year 2002} \rightarrow \left(\frac{75}{200} \times 100 \right) = 37.5\%$$

$$\text{year 2003} \rightarrow \left(\frac{50}{100} \times 100 \right) = 50\%$$

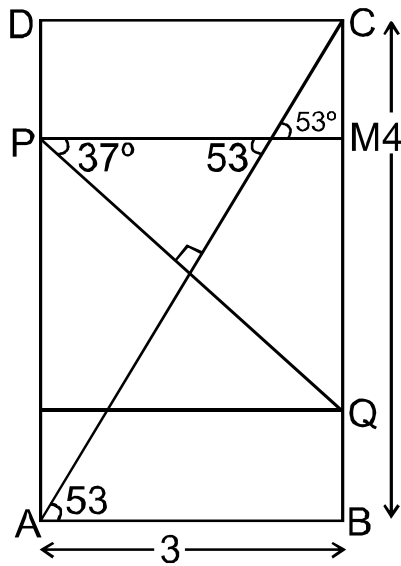

2.(2)

Given $AB = 3$

$BC = 4$

then from using pythagoras

$AC = 5$ m

and $\angle CAB = \theta$

then $\tan \theta = \frac{4}{3} = \tan 53^\circ \quad \dots(i)$

Then in $\triangle PMQ$

$\sec 37^\circ = \frac{PQ}{PM} \quad \dots(ii)$

Using $\triangle ABC$

$\sec 37^\circ = \frac{5}{4} \quad \dots(iii)$

Using (iii) in (ii)

$$\frac{5}{4} \times PM = PQ$$

$$PQ = \frac{5}{4} \times 3 = \frac{15}{4}$$

3.(2) Using allegation Formula:

Quantity of Cheaper/ Quantity of dearer= (high value-mean value)/(mean value-low value)

volume of pour Space/Volume of rice=1.5-0.80.8-0=78

So volume of pour space=1000/15×7=466.66 approximately 465.

4.(1) Figure according to question AD and CD are equal because peacock and snake has equal speed.

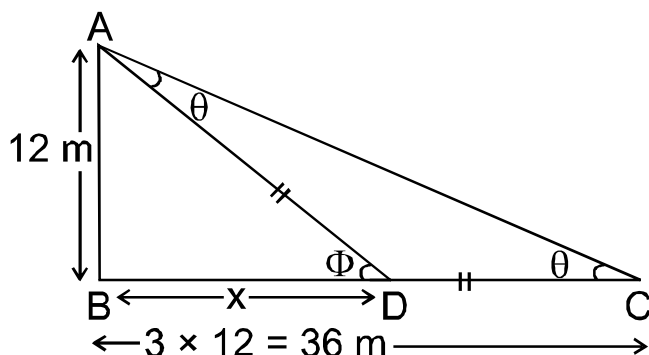

let $\angle DAC = \theta$

from the fig. $\angle DCA = \theta$

and let $\angle ADB = \Phi$

according to Geometry

$$\Phi = 2\theta$$

$$\tan 2\theta = \tan \Phi$$

$$\frac{2 \tan \theta}{1 - \tan^2 \theta} = \tan \Phi$$

$$\text{from the fig. } \tan \theta = \frac{12}{36} = \frac{1}{3}$$

$$\tan \Phi = \frac{12}{x}$$

$$\frac{\frac{2}{3}}{1 - \left(\frac{1}{3}\right)^2} = \frac{12}{x}$$

$$\frac{\frac{2}{3}}{\frac{8}{9}} = \frac{12}{x}$$

$$\frac{2}{3} \times \frac{9}{8} = \frac{12}{x}$$

$$\frac{1}{4 \times 4} = \frac{1}{x}$$

$$x = 16 \text{ m}$$

5(3) Distance of river on ground = perimeter of semi circle

$$= \pi \times r$$

$$= 3.14 \times 3.5$$

$$= 11 \text{ cm}$$

According to Scale = 11 x 50,000 cm

$$= 5,50,000 \text{ cm or } 5.5 \text{ km.}$$

6.(1) Given that the sum of squares of a nine digit number is 2. Then. The possible numbers would be

Case.I :

$$100000001$$

$$1^2 + 0^2 + 0^2 + 0^2 + 0^2 + 0^2 + 0^2 + 0^2 + 1^2 = 2$$

Case II :

$$100000010$$

$$1^2 + 0^2 + 0^2 + 0^2 + 0^2 + 0^2 + 0^2 + 1^2 + 0^2 = 2$$

Case III :

$$100000100$$

$$1^2 + 0^2 + 0^2 + 0^2 + 0^2 + 1^2 + 0^2 + 0^2 = 2$$

- Case IV :** 100001000
 $1^2 + 0^2 + 0^2 + 0^2 + 0^2 + 1^2 + 0^2 + 0^2 + 0^2 = 2$
- Case V :** 100010000
 $1^2 + 0^2 + 0^2 + 0^2 + 1^2 + 0^2 + 0^2 + 0^2 + 0^2 = 2$
- Case VI :** 100100000
 $1^2 + 0^2 + 0^2 + 1^2 + 0^2 + 0^2 + 0^2 + 0^2 + 0^2 = 2$
- Case VII :** 101000000
 $1^2 + 0^2 + 1^2 + 0^2 + 0^2 + 0^2 + 0^2 + 0^2 + 0^2 = 2$
- Case VIII :** 110000000
 $1^2 + 1^2 + 0^2 + 0^2 + 0^2 + 0^2 + 0^2 + 0^2 + 0^2 = 2$

7.(3) Given that

$$y = x$$

$$y = 1 - x \text{ and } x = 0$$

$$AB = BC$$

$$\& y = x = m_1 = 1$$

$$y = -x + 1 = m_2 = -1$$

so $m_1 m_2 = -1$, triangle is right - angled.

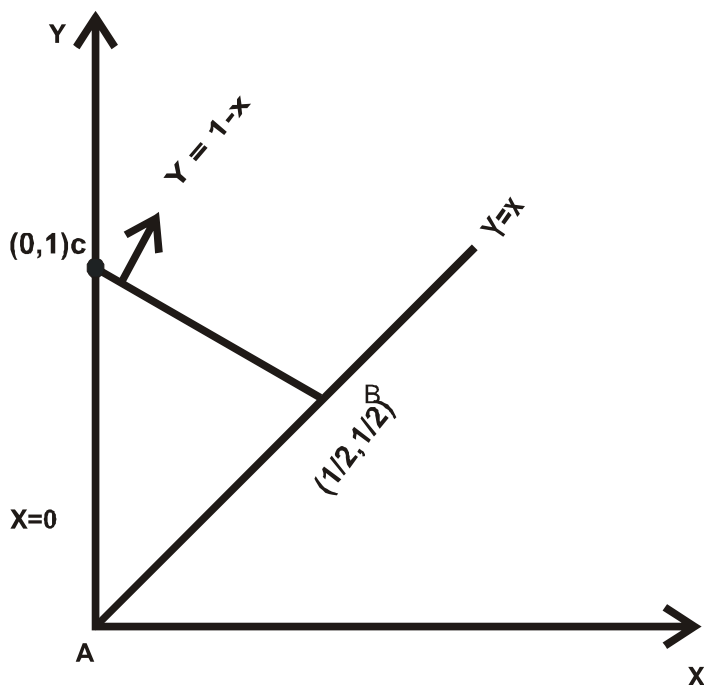

8.(2) The given sequence will follow the pattern 3, 4 4, 3

These are the difference between two consecutive numbers of the sequence.

So.

$$\begin{array}{ccccccc}
 39, & 42, & 46, & 50 & (53) \\
 \underbrace{\quad} & \underbrace{\quad} & \underbrace{\quad} & \underbrace{\quad} & \\
 +3 & +4 & +4 & +3 &
 \end{array}$$

9.(2) Volume of vessel upto height $2h$ is equal to $2a * 2h$... (1)

Volume of vessel after removing cylinder

$$= 2A * h' \quad \dots (2)$$

where h' = new height of water level.

Volume of water = Volume of vessel = Volume of solid

after removing upto height $2h$ Cylinder upto height cylinder h

$$\Rightarrow 2A * h' = 2A * 2h - A.h$$

$$\Rightarrow h' = \frac{3}{2} h$$

10.(1)

$$\text{gcd} = 20$$

$$\text{lcm} = 600$$

$$\text{lcm} = \frac{x * y}{\text{gcd}}$$

$$x * y = 600 * 20$$

$$x * y = 2^5 * 3^1 * 5^3$$

x	y
$5^1 * 2^2$	$5^2 * 2^3 * 3$
$5^2 * 2^2$	$5^1 * 2^3 * 3$
$5^2 * 2^3$	$5^1 * 2^2 * 3$
$5^2 * 2^2 * 3$	$5^1 * 2^3$

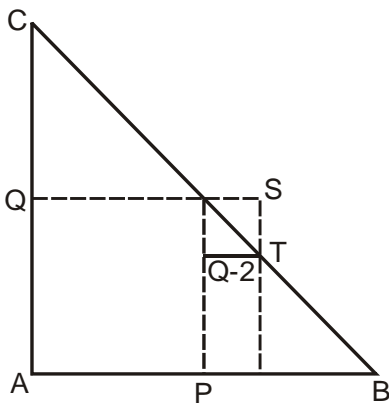

11.(3)

$$AB = AC = 3$$

$$AQ = 2 AP$$

$$\text{Area of } \Delta ABC = \frac{1}{2} b \times h = \frac{1}{2} (3 \times 3) = \frac{1}{2}$$

$$\text{Area of } \Delta QST = \frac{1}{2} (Q.2 \times Q.2) = 0.02$$

$$\text{Ratio} = \frac{9 \times 100}{2 \times 0.02} = 225$$

12.(2) CP for the customer: $100+10=110$

and 10% of $110=11$ So customer sells shopkeeper at 99. SO Shopkeeper makes a profit of Rs $10+1=11$.
2nd option is correct.

OR

A shopkeeper purchases a product Rs.100 and sales it making a profit 10%,then profit = 10 Rs.Again customer resells it to the same increasing a loss of 10%. Then total loss = 11 Rs
= Total profit to the shopkeeper = $1+ 10 = 11$ Rs

13.(3) 500 gm of Pure coffee contains \rightarrow 50 gm of chicory

100 gm of Pure coffee contains \rightarrow 10 gm of chicory

Now;

5 gm is added additionally

i.e., 105 gm of coffee \rightarrow 15 gm of chicory

$$\% = \frac{15}{105} \times 100 = \frac{100}{7} = 14.2\% \square 14\%$$

14.(4) Raw material and Research & Development have registered increase by same percentage.

Increase in raw material from 2010 to 2011 = $6240-5200 = 1040$

Percent increase = $(1040/6240) \times 100 = 16.6 \%$

Increase in Research & Development from 2010 to 2011

$$= 26400 - 22000 = 4400$$

Percent increase = $(4400/26400) \times 100 = 16.6 \%$

15.(3) The formula used in this operation is as follows :

B (+4), F(+2) H (+4), L (+2) N (+2) P (+4), T(+2) V(+2) X (+2) Z

So next one is TVXZ

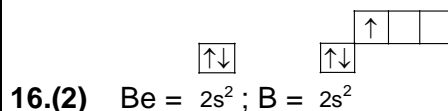

Unpaired electron in B is easier to remove than that paired electron in Be. Hence $(IE)_1$ of Be $>$ $(IE)_1$ of B and by $(IE)_1$ Be^+ and B^+ are formed.

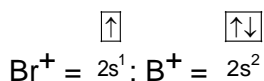

Now reverse is the case; removal of unpaired electron from Be^+ is easier than that of paired electron from B^+ . Hence $(IE)_2$ of B $>$ $(IE)_2$ of Be.

17. (4) Bond angles $\angle \text{F} - \text{S} - \text{F}$ follows the order

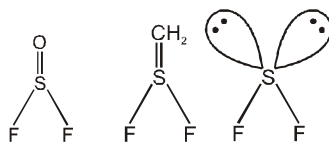
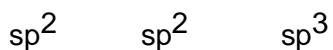
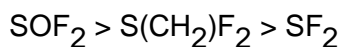

So the double bond pair is more towards oxygen atom in SOF_2 , the $\text{F} - \text{S} - \text{F}$ angle is more expanded, while the double bond pair is more towards sulphur atom in $\text{S}(\text{CH}_2)\text{F}_2$. So the $\text{F} - \text{S} - \text{F}$ bond angle is slightly shrunk (contracted).

18.(4) SQUIDS — Superconducting Quantum Interference Devices.

This device is extremely sensitive to changes in magnetic field and can measure voltages as small as 10^{-18} V, current of 10^{-18} A and magnetic field of 10^{-14} T. SQUIDS are being used in medical research to detect small changes in magnetic field in the brain. Geologists employ these devices in prospecting for minerals and oil where deposits can cause small local changes in the earth's magnetic field.

19.(4) According to crystal field theory, Ni^{2+} can have two unpaired electrons in both octahedral and tetrahedral geometry.

Eg. $[\text{Ni}(\text{H}_2\text{O})_6]^{2+} = \text{Ni}^{2+} = 3d^8$

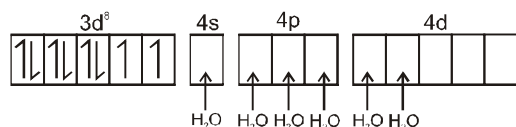

$[\text{NiCl}_4]^{2-} = \text{Ni}^{2+} = 3d^8$ (weak field)

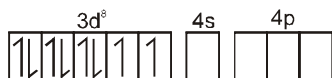

20.(2) Argon have stable full filled electronic configuration. So that's why Argon have the highest ionization potential.

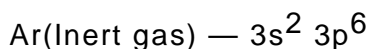

21.(3) Number of hybrid orbitals of P in $\text{PO}_4^{3-} = \frac{1}{2}[5 + 0 + 3] = 4(\text{sp}^3)$

No. of hybrid orbitals of N in $\text{NO}_3^- = \frac{1}{2}[5 + 0 + 1] = 3(\text{sp}^2)$

No. of hybrid orbitals of I in ICl_2^+ , I = $(5s^2 5p_x^2 5p_y^1 5p_z^1)$; $1/2 (7-1+0 +2) = 4(\text{sp}^3)$ Number of hybrid orbitals of I in ICl_4^+ = $1/2 (7-1+0 +4) = 5(\text{sp}^3d)$

22.(4) In N_2O , the bond order between N – N is between 2.5. N_2O is hybrid of following structures

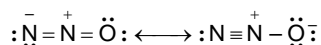

so the resonance hybrid has B.O

No. of covalent bond in or b/w given two bonded atom in all resonating structures

$$= \frac{2 + 3}{2}$$

$$= \frac{2 + 3}{2} = \frac{5}{2} = 2.5$$

23.(2) The maximum to minimum values of the quantum number J are given by

$$J = (j_1 + j_2), (j_1 + j_2 - 1), (j_1 + j_2 - 2) \dots |j_1 - j_2|$$

∴ For $j_1 = 2$ & $j_2 = 4$, we have

$$J_{\text{max}} = 2 + 4 = 6$$

$$J_{\min} = |2 - 4| = 2$$

Hence possible values are $J = 6, 6 - 1, 6 - 2, 6 - 3, 6 - 4,$

$$\therefore J = 6, 5, 4, 3, 2.$$

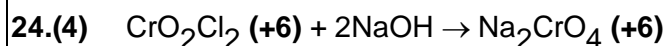

25.(3) The increasing order of the spectrochemical series is given below :

$\text{I}^- < \text{Br}^- < \text{S}_2^{2-} < \text{SCN}^- < \text{Cl}^- < \text{NO}_3^- < \text{N}_3^- < \text{F}^- < \text{OH}^- < \text{C}_2\text{O}_4^{2-} < \text{H}_2\text{O} < \text{NCS}^- < \text{CH}_3\text{CN} < \text{py (pyridine)} < \text{NH}_3 < \text{en (ethylenediamine)} < \text{bipy (2,2'-bipyridine)} < \text{phen (1,10-phenanthroline)} < \text{NO}_2^- < \text{PPh}_3 < \text{CN}^- \gg \text{CO}$

26.(2) A solution of lanthanide ions is run down a column of synthetic ion-exchange resin such as Dowex-50.



The H^+ ions produced are washed through the column. Then the metal ions are eluted, which are washed off the column in a selective manner. The eluting agent is a complexing agent, for example a buffered solution of citric acid/ammonium citrate or a dilute solution of $(\text{NH}_4)_3(\text{H}.\text{EDTA})$ at pH 8. Consider the citrate case. An equilibrium is set up —

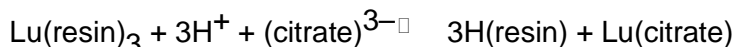

As the citrate solution flows down the column, Lu^{3+} ions are removed from the resin and form the citrate complex. A little lower down the column the Lu^{3+} ions go back onto the resin. As the citrate solution runs down the column the metal ions form complexes alternately with the resin and the citrate solution many times. The metal ion gradually travels down the column and eventually passes out of the bottom of the column as the citrate complex. The smaller lanthanide ions such as Lu^{3+} form stronger complexes with the citrate ions than do the larger ions like La^{3+} . Thus the smaller and heavier ions spend more time in solution and less time on the column and are thus eluted from the column first.

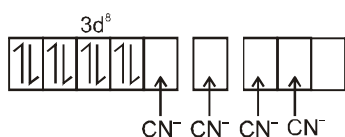
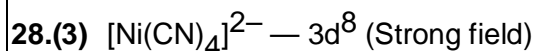
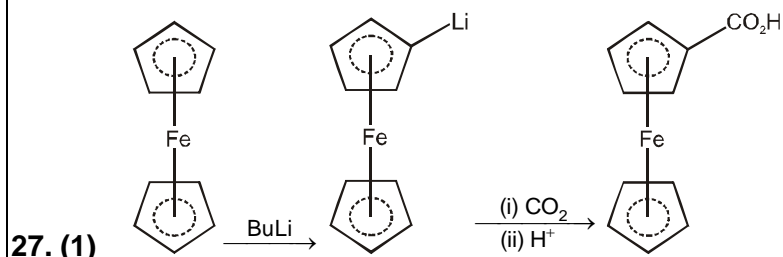

Diamagnetic

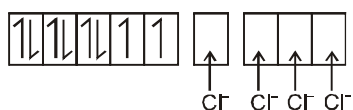
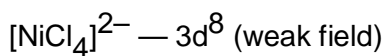

Paramagnetic = 2 unpaired e^-

29.(2) Epoxidation of (Z)-2-butene gives the meso (achiral) epoxide. Oxygen transfer from the peroxy acid can occur at either face of the double bond, but the product formed is the same because the two mirror-image forms of the epoxide are superimposable.

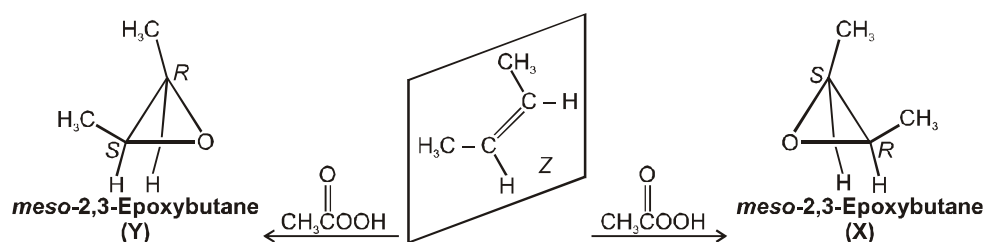

Epoxidation of (E)-2-butene gives a racemic mixture of two enantiomeric epoxides.

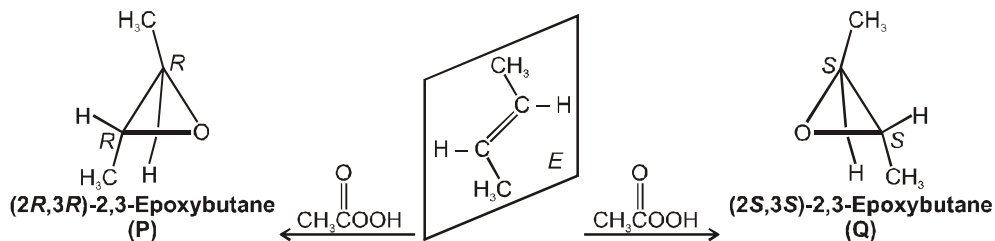

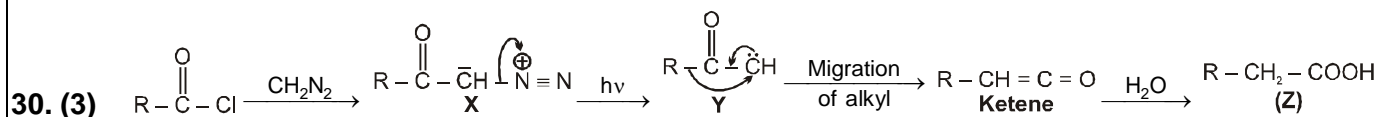

31.(2) (a) **Aromatic, 6 π electrons** — (Here 2 unshared electrons on N overlap in the π system), follows Huckel's rule.

(b) **Aromatic, 6 π electrons** — (Here unshared electron pair on N does not participate in the p overlap), follows Huckel's rule.

(c) **Non aromatic, 6 π electrons** — (Here the methylene C is sp^3 hybridized)

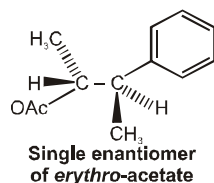
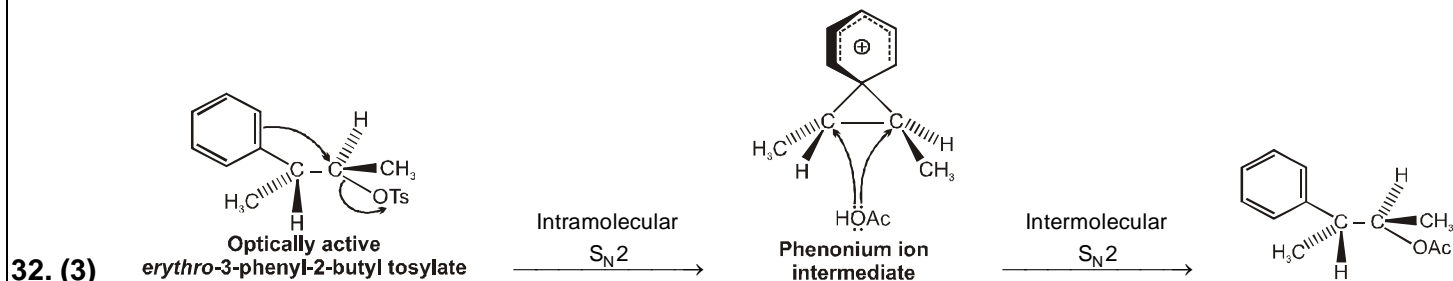

Benzene is acting as neighbouring group and the result is phenonium ion.

Opening of phenonium ion (chiral) gives a single enantiomer.

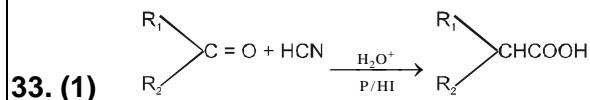

R_1, R_2 may be H or $\begin{matrix} \text{CHOH} \\ | \\ \text{---} \end{matrix}$ or $-\text{CH}_2\text{OH}$

If R_1 is H (as in glucose) chain is increased.

If R_1 is CH_2OH (as in fructose), chain is not affected or decreased.

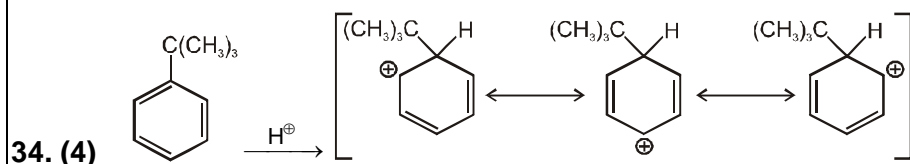

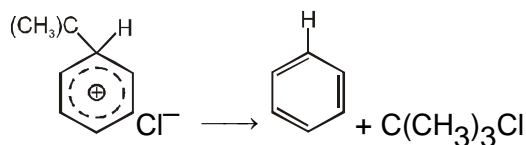

35. (2) The conversion requires reduction; however, the conditions necessary (LiAlH_4) would also reduce the ketone carbonyl. The ketone functionality is therefore protected as the cyclic acetal.

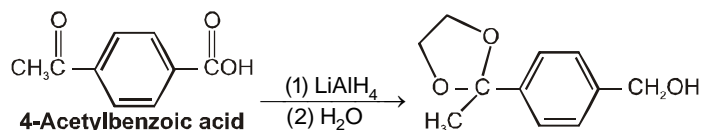

Reduction of the carboxylic acid may now be carried out.

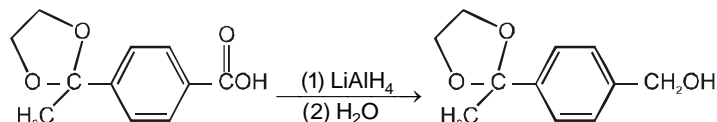

Hydrolysis to remove the protecting group completes the synthesis.

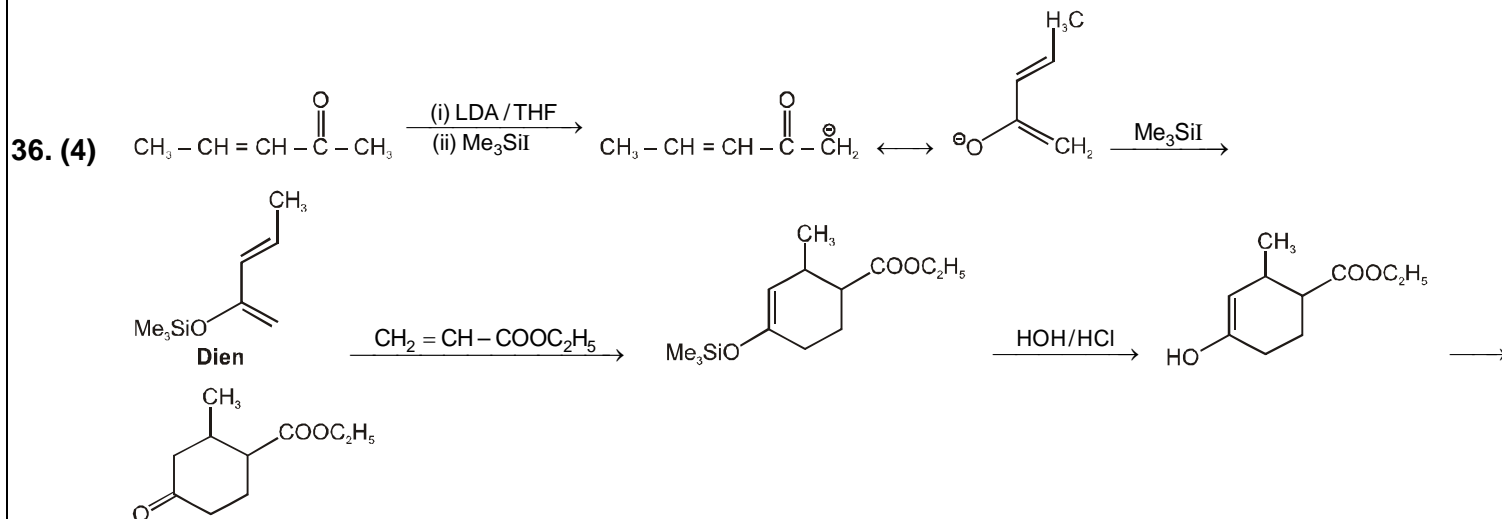
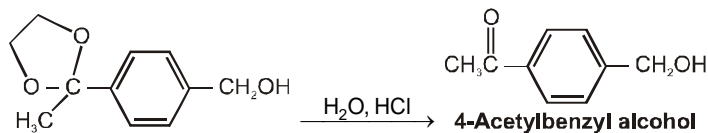

37. (2) *t*-Butyl hydroperoxide is used for selective epoxidation of the double bond of allyl alcohol. The reaction of geraniol with *t*-butyl hydroperoxide in boiling benzene in presence of catalytic amount of vanadium acetylacetonate gives exclusively the 2,3-epoxide. However, with peroxyacids the epoxidation occurs

preferentially at the other double bond.

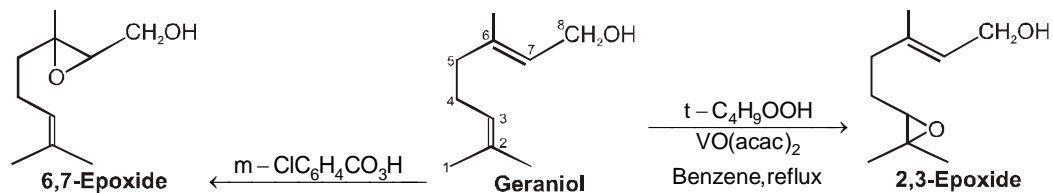

38. (3)

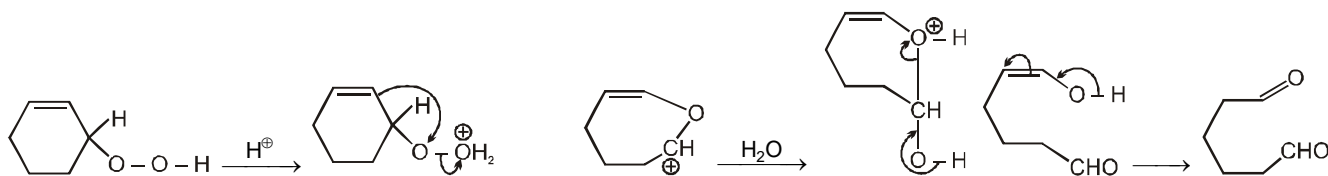

39. (3)

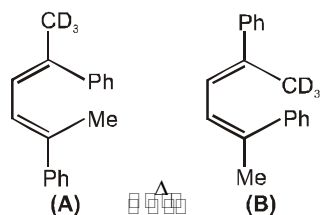

Both the steps are symmetry allowed under thermal conditions. Since the HOMO (ψ_2) of the open chair partner will have C_2 symmetry, therefore, both ring-closure and ring opening will be conrotatory process.

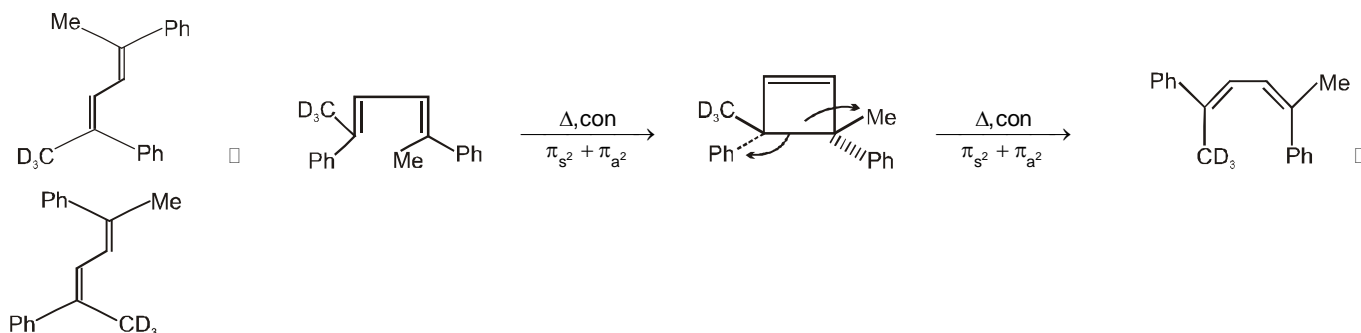

40. (3)

At constant temperature the final pressure (P) = $\frac{P_A V_A + P_B V_B}{\text{Total Volume}}$

$$P = \frac{2 \times 1 + 3 \times 2}{4} = \frac{2 + 6}{4} = 2 \text{ atmosphere}$$

41. (1)

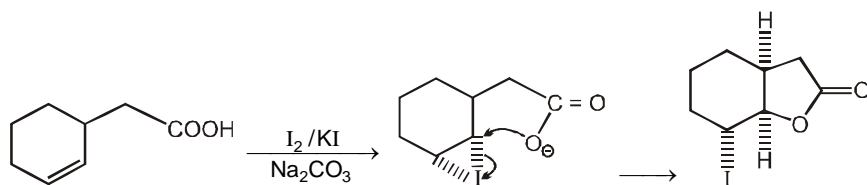

42.(1) The energy of photon (E) = hv

$$E = \frac{hc}{\lambda}$$

Given $h = 6.6 \times 10^{-27}$ erg-second

$$c = 3 \times 10^{10} \text{ cm/sec.}$$

$$l = 3000 \text{ \AA} = 3000 \times 10^{-8} \text{ cm}$$

$$E = \frac{6.6 \times 10^{-27} \times 3 \times 10^{10}}{3000 \times 10^{-8}} = 6.6 \times 10^{-12} \text{ erg}$$

43. (4) Partial pressure of C_2H_6 = Mole fraction \times Total pressure

$$\text{No. of Moles of } C_2H_6 = \frac{60}{30} = 2$$

$$\text{No. of Moles of CO} = \frac{28}{28} = 1$$

$$\text{Mole fraction of } C_2H_6 = \frac{n_{C_2H_6}}{n_{C_2H_6} + n_{CO}} = \frac{2}{2+1} = \frac{2}{3}$$

$$\text{Partial pressure of } C_2H_6 = \frac{2}{3} \times 3 = 2 \text{ atm}$$

44. (2) $CH_3COOH \rightleftharpoons CH_3COO^- + H^+$

t = 0	C	0	0
at equilibrium	$C(1 - \alpha)$	$C\alpha$	$C\alpha$

$$K_a = \frac{[CH_3COO^-][H^+]}{[CH_3COOH]} = \frac{C\alpha \times C\alpha}{C(1-\alpha)}$$

CH_3COOH is a very weak electrolyte.

So $\alpha \ll 1$ $1 - \alpha = 1$

$$K_a = C\alpha^2$$

$$\alpha = \sqrt{\frac{K_a}{C}}$$

Given $K_a = 2 \times 10^{-5} \text{ Mol dm}^{-3}$

$$C = 0.2 \text{ M}$$

$$\alpha = \sqrt{\frac{2 \times 10^{-5}}{0.2}} = 1 \times 10^{-2}$$

$$[\text{H}^+] = C\alpha = 0.2 \times 10^{-2} \text{ mol. dm}^{-3} = 2 \times 10^{-3} \text{ mol. dm}^{-3}$$

45. (1) Triple point of CO_2 lies at 5.2 atm. A significant feature of carbon dioxide is that even at atmospheric pressure carbon dioxide can be directly solidified without the appearance of liquid phase. So both Reason and Assertion are correct. Solid CO_2 is also called Dry ice.

46. (3) S.No.	A mol l ⁻¹	B mol l ⁻¹	Rate mol l ⁻¹ t ⁻¹
I	1×10^{-2}	2×10^{-2}	2×10^{-4}
II	2×10^{-2}	2×10^{-2}	4×10^{-4}
III	2×10^{-2}	4×10^{-2}	8×10^{-4}

$$\text{Rate} = k[\text{A}]^x[\text{B}]^y$$

$$\text{From Exp. (I)} \quad 2 \times 10^{-4} = k[1 \times 10^{-2}]^x[2 \times 10^{-2}]^y \dots(i)$$

$$\text{From Exp. (II)} \quad 4 \times 10^{-4} = k[2 \times 10^{-2}]^x[2 \times 10^{-2}]^y \dots(ii)$$

$$\text{Dividing (ii) by Equ. (i)} \quad \frac{4 \times 10^{-4}}{2 \times 10^{-4}} = \frac{k[2 \times 10^{-2}]^x[2 \times 10^{-2}]^y}{k[1 \times 10^{-2}]^x[2 \times 10^{-2}]^y}$$

$$[2]^1 = [2]^x$$

$$x = 1$$

$$\text{From Exp. (II)} \quad 4 \times 10^{-4} = k[2 \times 10^{-2}]^x[2 \times 10^{-2}]^y \dots(ii)$$

$$\text{From Exp. (III)} \quad 8 \times 10^{-4} = k[2 \times 10^{-2}]^x[4 \times 10^{-2}]^y \dots(iii)$$

$$\text{Dividing Equ. (iii) by (ii)} \quad \frac{8 \times 10^{-4}}{4 \times 10^{-4}} = \frac{k[2 \times 10^{-2}]^x[4 \times 10^{-2}]^y}{k[2 \times 10^{-2}]^x[2 \times 10^{-2}]^y}$$

$$[2]^1 = [2]^y$$

$$y = 1$$

Rate law of the reaction is $(k) = k[\text{A}][\text{B}]$

On doubling the concentration of both reactant

$$\text{Rate} = k[2\text{A}][2\text{B}] = 4k[\text{A}][\text{B}]$$

From Equi. (i) $2 \times 10^{-4} = k[1 \times 10^{-2}][2 \times 10^{-2}]$

$$k = \frac{2 \times 10^{-4}}{2 \times 10^{-4}} = 1 \text{ mol}^{-1} \text{ sec}^{-1}$$

So statement 2 and 3 are correct.

47. (1) $E_{\text{cell}} = \frac{0.0591}{2} \log \frac{(P_2)}{(P_1)}$ at 25°C

Given $P_1 = 1$; $P_2 = 100$

$$E_{\text{cell}} = \frac{0.0591}{2} \log \frac{100}{1} = \frac{0.0591}{2} \log 10^2 = \frac{0.0591}{2} 2 \log 10 = 0.0591 \text{ V}$$

48. (3) $E = E^0 - \frac{RT}{nF} \ln Q$

At equilibrium $E_{\text{cell}} = 0$

So equilibrium const. $H_C = Q$

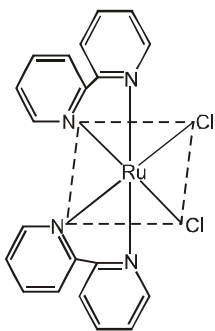

cis isomer

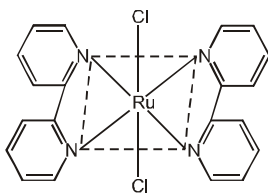

trans isomer

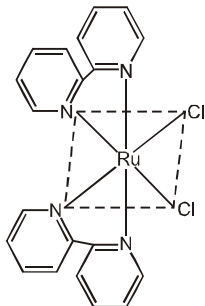

cis-d-isomer

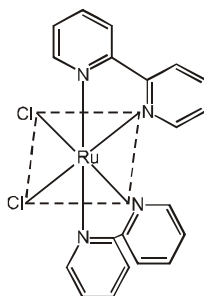

cis-l-isomer

The number of possible isomers for $[\text{Ru}(\text{bpy})_2\text{Cl}_2]$ is 3.

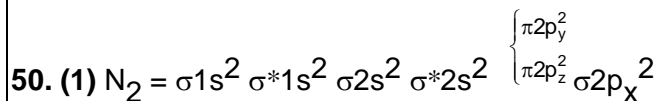

HOMO — $\sigma 2p_x$

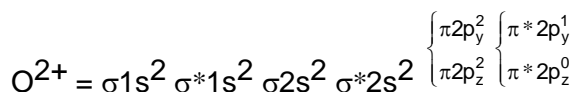

HOMO — $\pi^* 2p_y$

51.(3) Heme group in cytochrome C has a polypeptide chain attached and around it. This chain contains a variable number of amino acids ranging from 103 to 112. A nitrogen atom from a histidine segment and a sulphur atom from a methionine segment of this chain are coordinated to the fifth and sixth coordination sites of the iron atoms. Thus unlike myoglobin (or hemoglobin) there is no position for further coordination. Therefore it can bind a dioxygen molecule (oxygen storage protein) cytochrome C, therefore, cannot react by simple coordination but must react indirectly by an electron transfer mechanism. It can reduce the dioxygen and transmit its oxidising power towards the burning of food and release of energy in respiration (the reverse process to complement photosynthesis). Thus cytochrome c is a redox protein and myoglobin is a oxygen storage protein.

52.(3) The symmetry point groups for a free SO_4^{2-} ion should be T_d due to the presence of more than one of the highest order C_3 axis in the tetrahedral structure. The latter case has C_{3v} point group as described below.

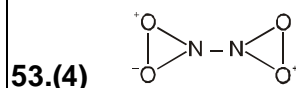
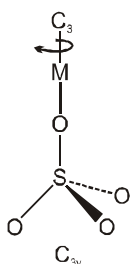
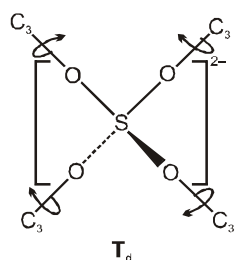

This mode of N_2O_4 is neither infrared active nor Raman active because no change in dipole moment or polarizability occurs.

54.(2) Fe^{2+} and Fe^{3+} have different shifts because 3s wave function extends away from the nucleus and is screened by 3p and 3d electrons. In Fe^{2+} , the 4s electrons are screened by six d-electrons while in Fe^{3+}

by five d-electrons. Hence Fe^{2+} salts are shifted to more positive value as compared to ferric salts. In Statement II When oxygen binds to it, it changes to low spin Fe(II). Low-spin Fe^{2+} binds to singlet oxygen. It is oxygenation (adding oxygen) rather than oxidation, because the iron doesn't change oxidation state. This is a reversible process. When no oxygen bound, the iron is high spin Fe(II). Both low-spin iron and singlet oxygen are diamagnetic. However, the singlet form of oxygen is the higher-energy form of the molecule. Iron(II) tends to exist in a high-spin configuration where unpaired electrons exist in E_g antibonding orbitals.

- 55.(2) **HF [linear without centre of symmetry, (i)]** — It belongs to the $C_{\infty v}$ point group and has the symmetry elements — E, C_{∞} and $\infty \sigma_v$ (Fig.).

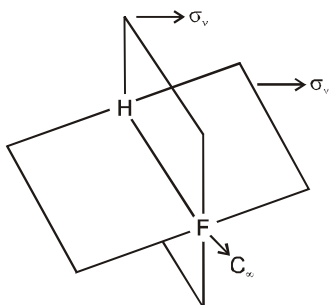
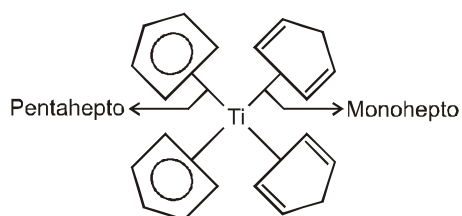
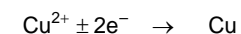
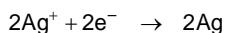

Fig. — Symmetry elements of the $C_{\infty v}$ point group in HF.

- 56.(3) In $\text{Ti}(\text{C}_5\text{H}_5)_4$ two types of bonds are present. Among these two are monohepto two are pentahepto.



In fluxional molecule averaging of two different nuclear environments occur as a result of intramolecular rearrangement resulting in one proton NMR signal. However, at low temperature this exchange is slow enough to give two sharp proton NMR signals, indicating two types of cyclopentadienes.



- 57.(3) $2\text{Ag}^+ + \text{Cu} \rightarrow 2\text{Ag} + \text{Cu}^{2+}$

$$E^0 = E_{\text{cathode}} - E_{\text{anode}} = 0.50 - 0.34 = 0.16 \text{ V}$$

$$E = E^{\circ} - \frac{0.0591}{2} \log \frac{[\text{Cu}^{2+}]}{[\text{Ag}^+]^2} = 0.16 - \frac{0.0591}{2} \log \frac{635}{(1080)(1080)}$$

$$= 0.16 + \frac{0.0591}{2} \log \frac{(1080)(1080)}{635} = 0.16 + 0.096 = 0.256$$

$$E = E^{\circ} - \frac{0.0591}{2} \log \frac{[\text{Ag}]}{[\text{Ag}^+]^2}$$

$$0.256 = E^{\circ} - \frac{0.0591}{2} \log \frac{1}{[0.1]^2}$$

$$0.256 = E^{\circ} + \frac{0.0591}{2} \log(0.01)$$

$$0.256 = E^{\circ} - 0.0591$$

$$E^{\circ} = 0.31 \text{ V}$$

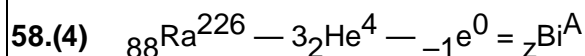

Comparing the mass numbers

$$226 - (3 \times 4) - 0 = A$$

$$A = 214$$

Comparing the atomic numbers

$$88 - (3 \times 2) - 1 \times (-1) = z$$

$$z = 83$$

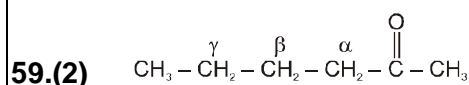

There is involvement of Mc Lafferty rearrangement in which hydrogen at the γ -position is abstracted by the heteroatom viz; oxygen with the elimination of the alkene, $\text{CH}_3 - \text{CH} = \text{CH}_2$.

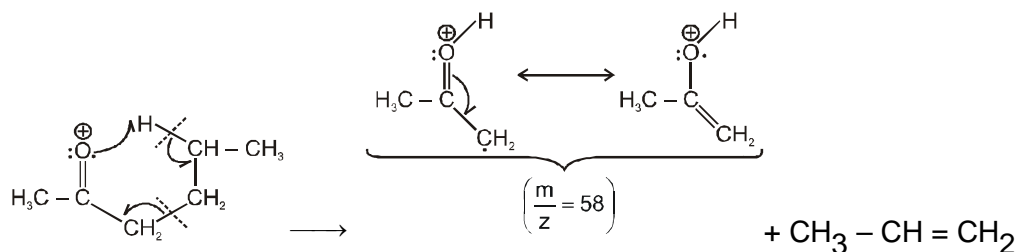

60.(4) Because the groups at both ends of the carbohydrate chain are oxidized to carboxylic acid functions, two combinations of one CH_2OH with one CHO group are possible.

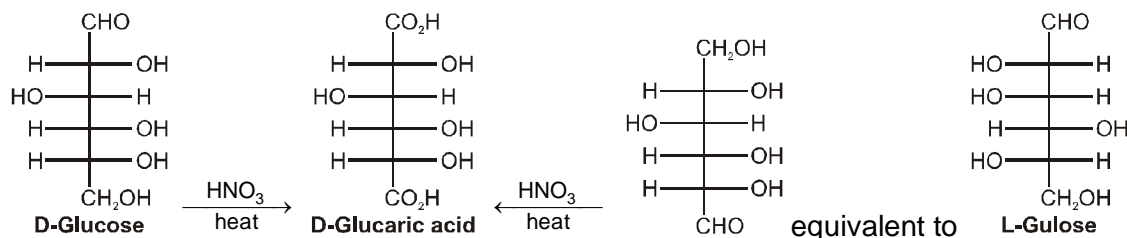

L-Gulose yields the same aldaric acid on oxidation as does D-glucose.

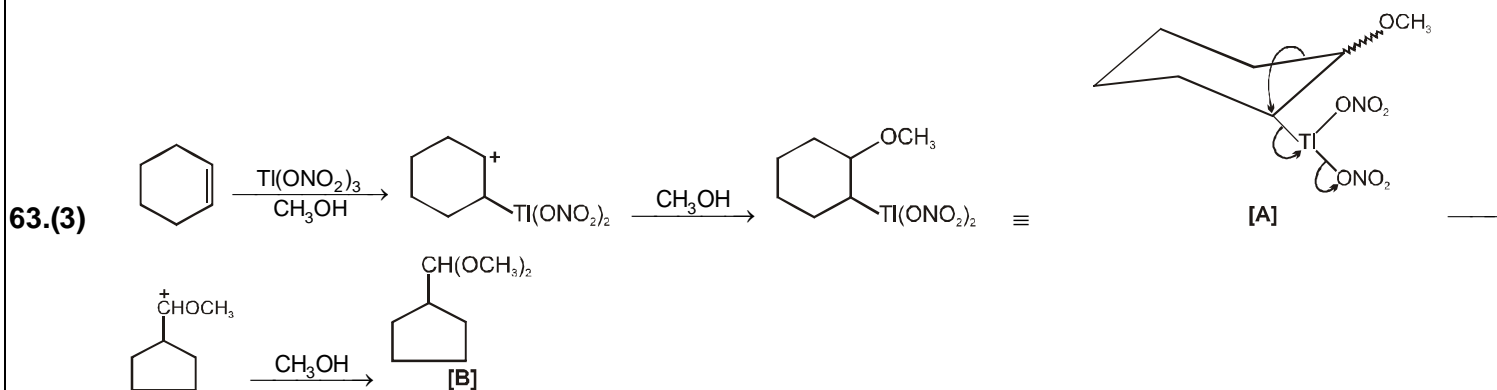
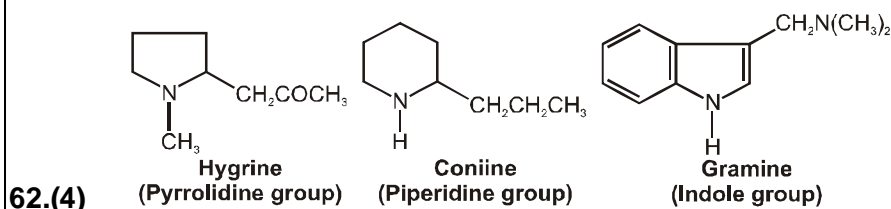
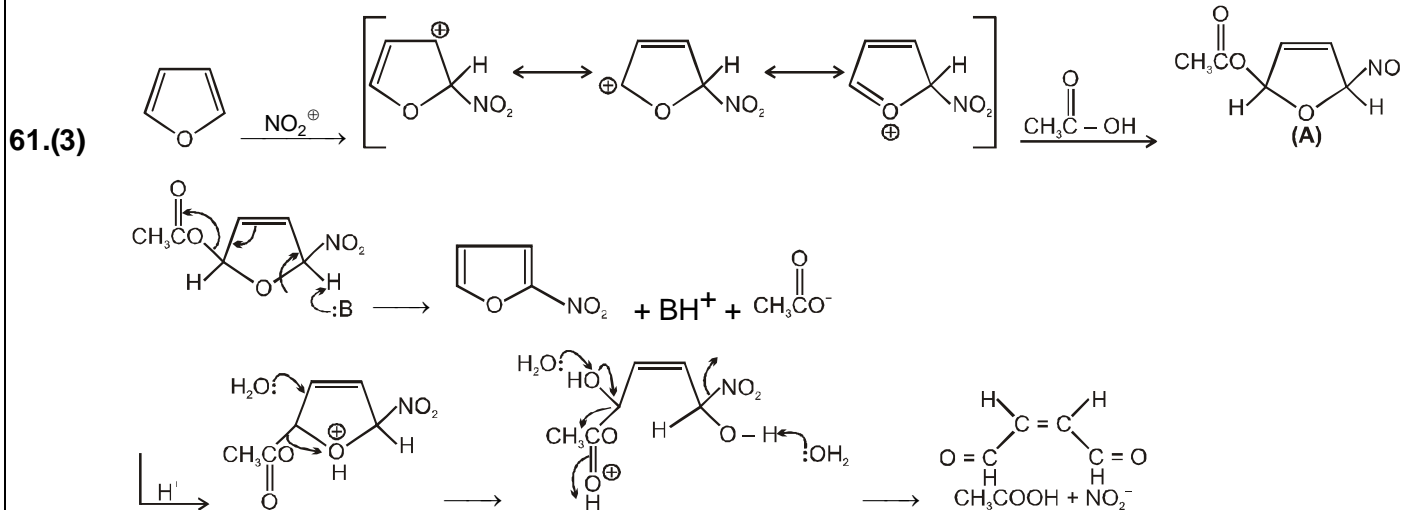

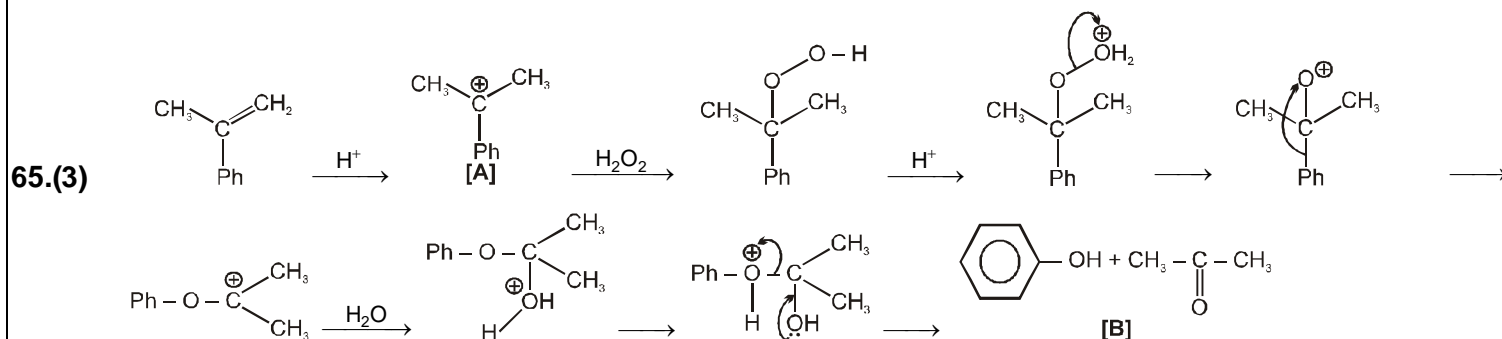
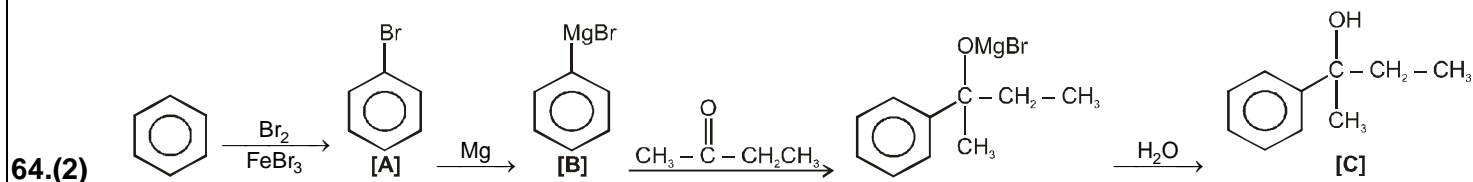

66.(4) (A) Favorskii Reaction —

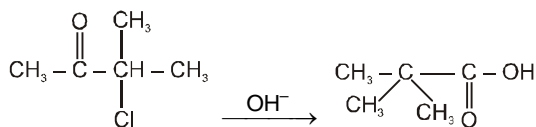

(2) Benzoin Condensation —

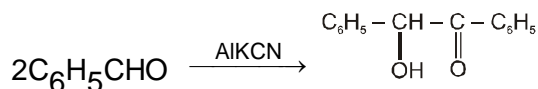

(3) Wolf Rearrangement —

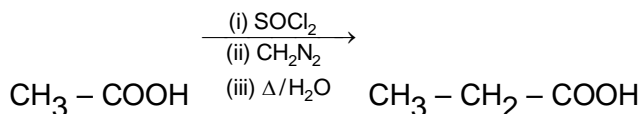

67.(4) Mass defect

$$= [234.0439 + 1.00866] - [141.9164 + 90.9234 + 3 \times 1.00866]$$

$$= 236.05256 - 235.86578 = 0.18678 \text{ amu}$$

Energy released in one fission

$$= 0.18678 \times 931 \text{ MeV} = 173.89 \times 10^6 \text{ eV}$$

$$= 173.89 \times 10^6 \times 6.023 \times 10^{23} \times 1.6 \times 10^{-19}$$

$$= 1675.7 \times 10^{10} \text{ J/mole} = 1.68 \times 10^{10} \text{ kJ/mol}$$

68.(2) $\lambda = \frac{h}{mV}$

$$\frac{\lambda_1}{\lambda_2} = \frac{m_2 V_2}{m_1 V_1}$$

$$\frac{1}{\lambda_2} = \frac{.25m \times .75V}{mV}$$

$$\lambda_2 = \frac{10000}{1875} = 5.33 \text{ \AA}$$

69.(4) According to de Broglie principle

$$\lambda = \frac{h}{\sqrt{2mE}} \quad \dots(i)$$

We also know that boundary conditions are also satisfied by sine functions if

$$\sqrt{2mE} \frac{L}{h} = n\pi \quad \dots(ii)$$

From equation (i) and (ii), we have $\frac{2\pi L}{\lambda} = n\pi$ and $\lambda = \frac{2L}{n}$

Therefore, the wavelength of the particle in a box can take the values

$$\lambda = 2L, L, \frac{2}{3}L, \frac{1}{2}L, \dots, \frac{2L}{n}, \dots$$

70.(4) $t_{1/2} = \frac{1}{K_2[A]_0}$

$$[A]_0 \propto P_0$$

$$K_2 = \frac{1}{400 \times 250} = 10^{-5} \text{ Torr}^{-1} \text{ s}^{-1}$$

if $P_0 = 200 \text{ Torr}$

$$t_{1/2} = \frac{1}{10^{-5} \times 200} = 500 \text{ sec}^{-1}$$

71. (4) $J_{\max} = \left(\frac{kT}{2hcB} \right)^{1/2} - \frac{1}{2} = \left[\frac{(1.38 \times 10^{-23} \text{ JK}^{-1})(300 \text{ K})}{2(6.626 \times 10^{-34} \text{ Js})(3 \times 10^{10} \text{ cm s}^{-1})(1.566 \text{ cm}^{-1})} \right]^{1/2} - \frac{1}{2} = 7.56 = 8$

72. (3) A/C Graham's law

$$r \propto \frac{1}{\sqrt{M}}$$

$$r \propto P$$

$$\frac{r_A}{r_B} = \left(\frac{P_A}{P_B} \right) \left(\frac{M_B}{M_A} \right)^{\frac{1}{2}}$$

$$\frac{r_{H_2}}{r_{O_2}} = \frac{V}{t_2} = \sqrt{\frac{M_{O_2}}{M_{H_2}}}$$

73. (2)

$$\frac{V}{5} \times \frac{t_2}{V} = \sqrt{\frac{32}{2}}$$

$$\frac{t_2}{5} = \sqrt{16}$$

$$t_2 = 5 \times 4 = 20 \text{ s}$$

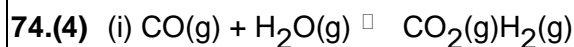

$$K_1 = \frac{[\text{CO}_2][\text{H}_2]}{[\text{CO}][\text{H}_2\text{O}]}$$

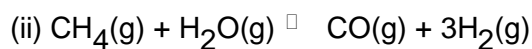

$$K_2 = \frac{[\text{CO}][\text{H}_2]^3}{[\text{CH}_4][\text{H}_2\text{O}]}$$

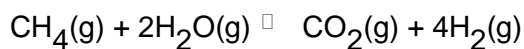

$$K = \frac{[\text{CO}_2][\text{H}_2]^4}{[\text{CH}_4][\text{H}_2\text{O}]^2}$$

$$K = \frac{K_1}{K_2} = \frac{[\text{CO}_2][\text{H}_2] \cdot [\text{CO}][\text{H}_2]^3}{[\text{CO}][\text{H}_2\text{O}] \cdot [\text{CH}_4][\text{H}_2\text{O}]}$$

75.(4) For A $T = 0.5$

$$A = -\log T$$

$$A = -\log 0.5 = 0.3010$$

$$A = \epsilon bc$$

$$\epsilon = \frac{0.3010}{0.1 \times 1} \text{ dm}^3 \text{ mol}^{-1} \text{ cm}^{-1}$$

For B $A = \epsilon bc = \frac{0.3010}{0.1} \times 0.5 \times 0.1 = 0.15051$

For C $T = 0.1$

$$A = -\log T = -\log 0.1 = 1$$

$C > A > B$.

VPM CLASSES is India's No. 1 Institute in CSIR UGC NET



BASUDEV ROY
AIR 1
PHYSICS
CSIR UGC NET



LINI K MATHEW
AIR 5
CHEMISTRY
CSIR UGC NET



SUNIL BHEL
AIR 5
MATHEMATICS
CSIR UGC NET



RINI VARGHESE
AIR 8
PHYSICS
CSIR UGC NET



M. VENU GOPAL
AIR 8
MATHEMATICS
CSIR UGC NET



JINIA SIKDAR
AIR 9
EARTH SCIENCE
CSIR UGC NET

Testimonials

“VPM CLASSES study material was the backbone of my exam preparation.”

Name : BASUDEV ROY,
Ranks : AIR 1 - CSIR UGC NET (DEC-2010) PHYSICS,
AIR 10 - GATE 2011 PHYSICS



Basudev Roy

TESTIMONIALS

“ I thank VPM CLASSES for the Good Quality Correspondence Course, as it helped me to qualify for CSIR UGC NET in Chemistry (Dec 2015) ”

NAME : MANDIRA CHATTERJEE

RANK : AIR 4

CSIR UGC NET DEC 2015 (CHEMISTRY)



Mandira Chatterjee

SCIENCE | ENGINEERING | COMMERCE | ARTS

IIT JAM, CSIR NET, GATE, UGC NET, SLET, TIFR, NIMCET, JEST, BHU, JNU, ISM etc.

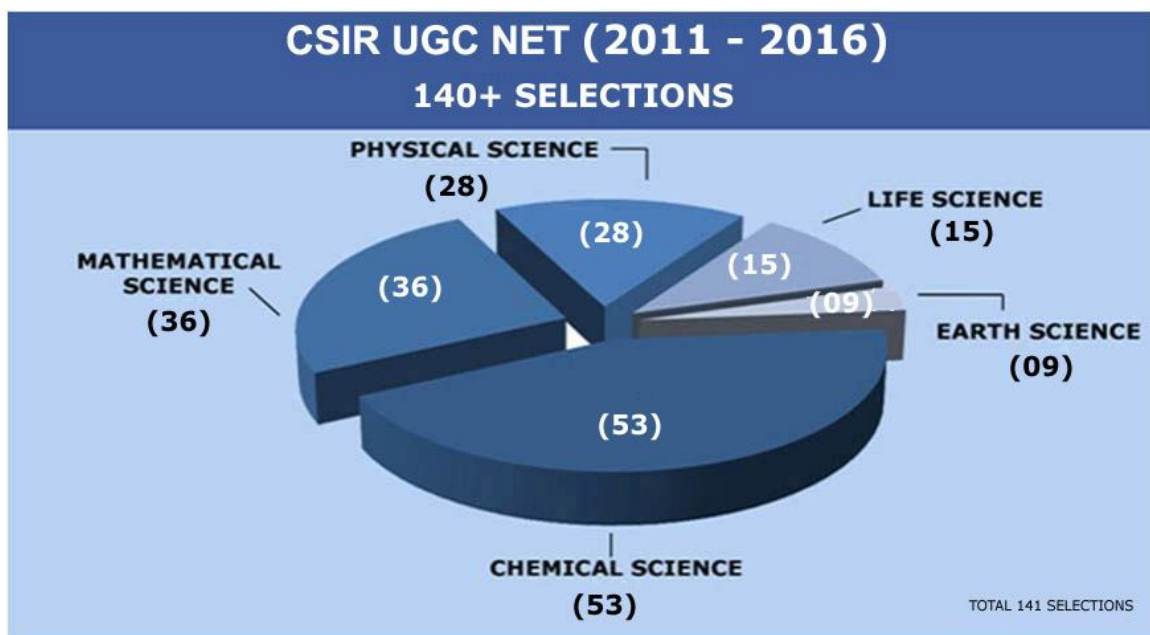

VPM CLASSES CSIR UGC NET RESULTS

141 SELECTIONS

(*including 32 ranks in june 2016 selections)



Anirban Bandyopadhyay
Mathematical
Science
AIR-11



Anirban Sarka
Physical Science
AIR-18



Debasis Haldar
Mathematical
Science
AIR-20

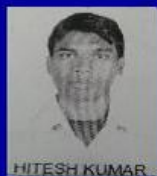

Hitesh Kuma
Life Science
AIR-30



Pranabendu Das
Chemical
Science
AIR-31



Shreya Mukherjee
Earth Science
AIR-74

32 selections in CSIR UGC NET JUNE 2016

Address (Head Office)	:-	VPM Classes, No. 8, Radha Nikunj – B Yojna, Opp. Iskcon Temple, Muhana Mandi Road, Near Mansarovar, Jaipur (Rajasthan), Pin Code - 302020
Mobile No	:-	9001297111 / 9829619614
Toll Free	:-	1800-2000-092
What's app	:-	9001894070 / 9001894076
Email	:-	info@vpmclasses.com , vpmclasses@yahoo.com
Website	:-	http://www.vpmclasses.com
Online Student Portal	:-	http://examprep.vpmclasses.com
Online Store	:-	http://store.vpmclasses.com
Online Test Portal	:-	http://onlinetest.vpmclasses.com
Facebook	:-	https://www.facebook.com/VpmClasses
Twitter	:-	https://twitter.com/vpmclasses
LinkedIn	:-	https://in.linkedin.com/in/vpmclasses
YouTube	:-	https://www.youtube.com/VpmClasses
APP	:-	https://play.google.com/store/apps/details?id=com.mylogics.ots&hl=en
Follow us on	:-	 / vpmclasses

