

## **CSIR NET - PHYSICAL SCIENCE**

### **SAMPLE THEORY**

#### **SPECIAL THEORY OF RELATIVITY**

- **INTRODUCTION**
- **POSTULATES OF SPECIAL THEORY OF RELATIVITY**
- **LORENTZ TRANSFORMATIONS(LT)**
- **CONSEQUENCES OF LT**
- **FOUR - VECTORS**
- **MASS ENERGY RELATION**
- **POINTS TO REMEMBER**
- **SOLVED PROBLEMS**

# **VPM CLASSES**

For IIT-JAM, JNU, GATE, NET, NIMCET and Other Entrance Exams

1-C-8, Sheela Chowdhary Road, Talwandi, Kota (Raj.) Tel No. 0744-2429714

Web Site [www.vpmclasses.com](http://www.vpmclasses.com) E-mail-[vpmclasses@yahoo.com](mailto:vpmclasses@yahoo.com)

Phone: **0744-2429714**

Website: [www.vpmclasses.com](http://www.vpmclasses.com)

Address: **1-C-8, Sheela Chowdhary Road, SFS, TALWANDI, KOTA, RAJASTHAN, 324005**

Mobile: **9001297111, 9829567114, 9001297243**

E-Mail: [vpmclasses@yahoo.com](mailto:vpmclasses@yahoo.com) / [info@vpmclasses.com](mailto:info@vpmclasses.com)

## INTRODUCTION

In Newtonian mechanics, space and time are completely separable and the transformation connecting the space-time coordinates of a particle are the Galilean transformations. These transformations are valid as far as Newton's laws are concerned, but fail in the field of electrodynamics. Principle of relativity, when applied to the electromagnetic phenomena, asserts that the speed of light in vacuum is a constant of nature.

## GALILEAN TRANSFORMATION

At any instant, the coordinates of a point or particle in space will be different in different coordinate systems. The equations which provide the relationship between the coordinates of two reference systems are called **transformation equations**.

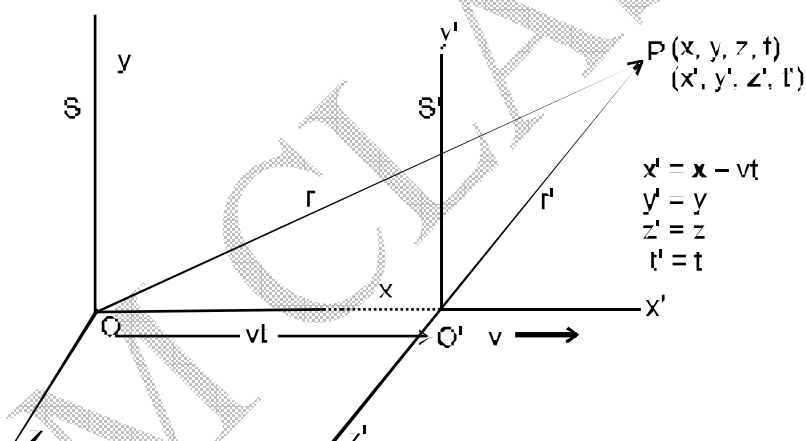

Fig . 1 Representation of Galilean transformations

$$x' = x - vt ; y' = y ; z' = z, t' = t \quad \dots(1)$$

These are referred as **Galilean transformations**.

$$x = x' + vt' ; y = y' ; z = z' ; t = t' \quad \dots(2)$$

These are known as **inverse Galilean transformations**.

$$L' = L \quad \dots (3)$$

Thus the length or distance between two points is invariant under Galilean transformations.

$$u = v + u' \quad \dots (4)$$

Where  $u$  and  $u'$  are the observed velocities in  $S$  and  $S'$  frames respectively and  $v$  is the velocity of the second frame relative to the first frame along  $x$ -axis.

Example: (4) transforms the velocity of a particle from one frame to another is known as Galilean **(or classical) law of addition of velocities.**

$$a = a'$$

Hence according to Galilean transformations, the accelerations of a particle relative to  $S$  and  $S'$  frames are equal.

It is to be mentioned that the Galilean transformations are based basically on two **assumptions**:

1. There exists a universal time  $t$  which is the same in all reference systems.
2. The distance between two points in various inertial systems is the same.

### POSTULATES OF SPECIAL THEORY OF RELATIVITY

The two fundamental postulates of the special theory of relativity are the following

- (1) All the laws of physics have the same form in all inertial systems, moving with constant velocity relative to one another. This postulate is just the principle of relativity.
- (2) The speed of light is constant in vacuum in every inertial system. This postulate is an experimental fact and asserts that the speed of light does not depend on the direction of propagation in vacuum and the relative velocity of the source and the observer. In fact, the second postulate is contained in the first because it predicts the speed of light  $c$  to be constant of nature.

### LORENTZ TRANSFORMATIONS

Suppose that  $S$  and  $S'$  be the two inertial frames of reference.  $S'$  is moving along positive direction of  $x$  - axis with velocity  $v$  relative to the frame  $S$ . Let  $t$  and  $t'$  be the times recorded in two frames. For our convenience, we will assume that the origins  $O$  and  $O'$  of the two  $\infty$  - ordinate systems coincide at  $t = t' = 0$ .

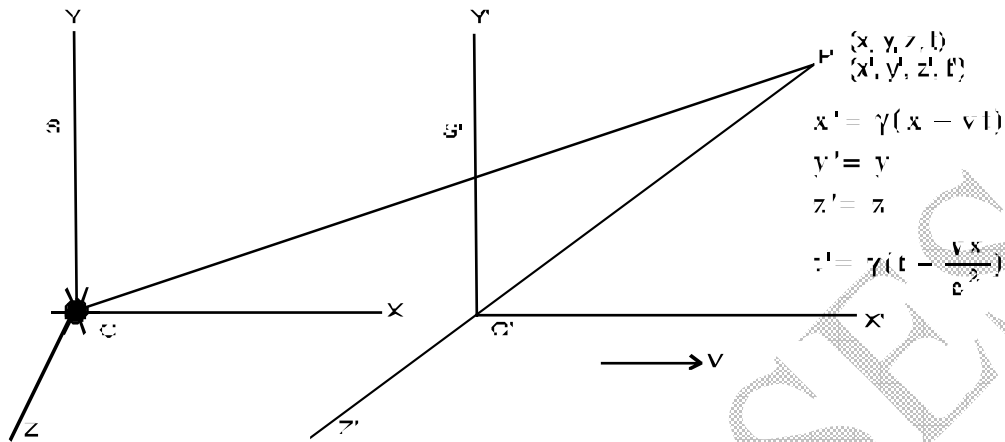

Fig. 2 Representation of Lorentz transformations

$$x' = \frac{x - vt}{\sqrt{1 - v^2/c^2}} ; y' = y, z' = z ; t' = \frac{t - vx/c^2}{\sqrt{1 - v^2/c^2}}$$

These equations are called **Lorentz transformations**.

$$1/\sqrt{1 - v^2/c^2} = 1/\sqrt{1 - \beta^2} = \gamma, \quad \beta = \frac{v}{c}$$

Hence the transformations are written as

$$x' = \gamma(x - vt); y' = y; z' = z, t' = \gamma\left(t - \frac{vx}{c^2}\right)$$

$$x = \gamma(x' - vt'); y = y'; z = z', t = \gamma\left(t' - \frac{vx'}{c^2}\right)$$

These are known as inverse Lorentz transformations.

### CONSEQUENCES OF LORENTZ TRANSFORMATIONS:

- (1) **Length Contraction:** In order to measure the length of an object in motion, relative to an observer, the positions of the two end points must be recorded simultaneously.

$$l_0 = x'_2 - x'_1$$

$$l = x_2 - x_1$$

$$l_0 = \gamma l$$

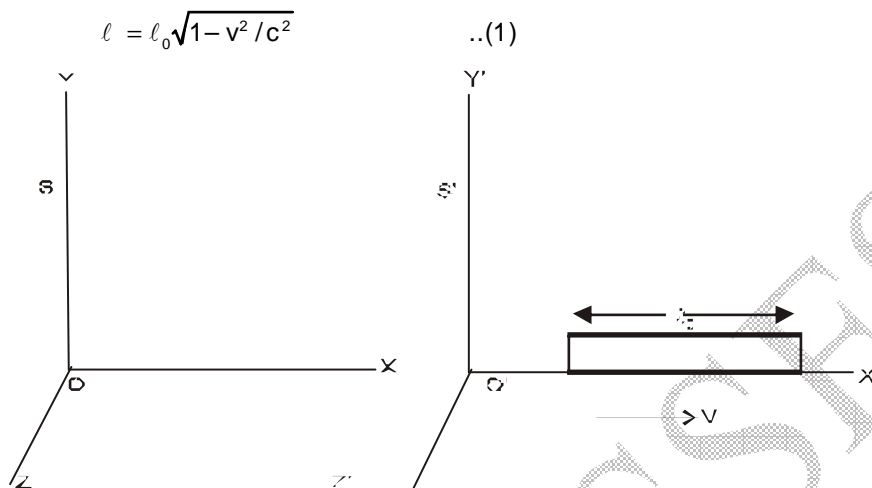

Fig. 3 Contraction of moving rod

As the factor  $\sqrt{1 - v^2/c^2}$  is smaller than unity, we have  $l < l_0$ . This means that the length of the rod ( $l$ ), as measured by an observer relative to which the rod is in motion, is smaller than its proper length. Such a contraction of length in the direction of motion relative to an observer is called **Lorentz - Fitzgerald contraction**.

(2) **Simultaneity:** If two events occur at the same time in a frame, they are said to be *simultaneous*.

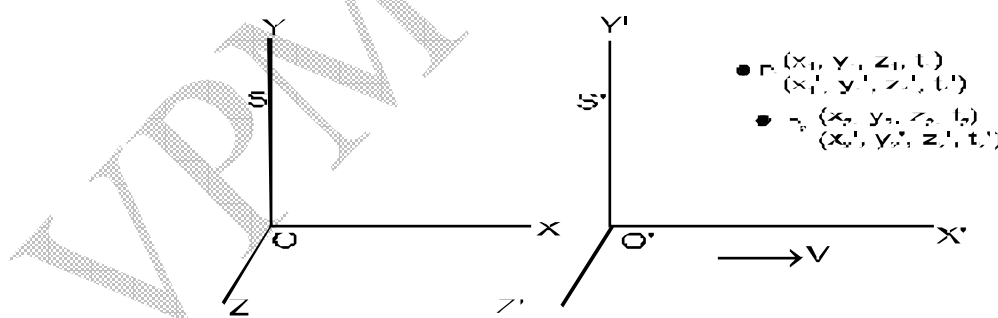

Fig. 4 Representation of two events in two inertial frames

$$t_2' - t_1' = -\frac{(v/c^2)(x_2 - x_1)}{\sqrt{1 - v^2/c^2}} \quad \dots(2)$$

- (3) **Time Dilation:** Let a frame  $S'$  be moving along  $X$ -axis with velocity  $v$  relative to  $S$ . Now, if a clock being at rest in the frame  $S'$ , measures the time  $t_1'$  and  $t_2'$  of two events occurring at a fixed position  $x'$  in this frame, then the interval of time between these events is

$$\Delta t' = t_2' - t_1' = \Delta t_0 \text{ (say)}$$

$$\Delta t = \frac{\Delta t_0}{\sqrt{1 - v^2/c^2}}$$

$$1/\sqrt{1 - v^2/c^2} > 1, \Delta t > \Delta t_0$$

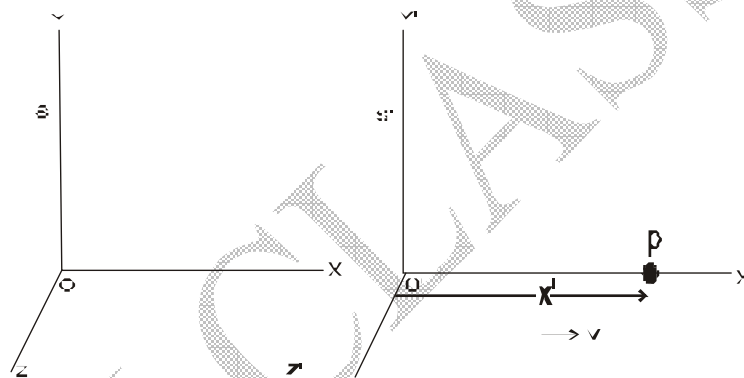

Fig. 5 Two events occur in frames  $S'$  at a fixed position  $x'$

Thus time interval, measured in the frame  $S$  is larger than the time interval in the frame  $S'$ , in which the two events are occurring at a certain  $x'$ . This effect is called **Time Dilation** (lengthening of time interval). This means to stationary observer the moving clock will appear to go slow.

If  $\Delta\tau$  is the decay half life of mesons of radioactive matter as measured in the frame  $S'$  in which the particles is at rest, then

$$\Delta t = \frac{\Delta\tau}{\sqrt{1 - v^2/c^2}} \quad \dots(3)$$

is the decay half life observed in a frame  $S$  in which the particles are moving with velocity  $v$ .

## FOUR – VECTORS

A vector in four dimensional Minkowski space is called a four - vector. Its components transform from one frame to another similar to Lorentz transformations.

An event in four dimensional space is represented by a world point  $(x_1, x_2, x_3, x_4)$ . The Lorentz transformations from S - frame to S' - frame correspond to orthogonal transformations in the four - space and are represented as

$$x'_\mu = \sum_{\nu=1}^4 a_{\mu\nu} x_\nu \quad \text{or} \quad \begin{pmatrix} x'_1 \\ x'_2 \\ x'_3 \\ x'_4 \end{pmatrix} = \begin{pmatrix} \gamma & 0 & 0 & i\beta\gamma \\ 0 & 1 & 0 & 0 \\ 0 & 0 & 1 & 0 \\ -i\beta\gamma & 0 & 0 & \gamma \end{pmatrix} \begin{pmatrix} x_1 \\ x_2 \\ x_3 \\ x_4 \end{pmatrix}$$

With the condition

$$\sum_{\mu=1}^4 x'^2_\mu = \sum_{\mu=1}^4 x^2_\mu$$

We may represent the position vector of a world point by

$$x_\mu = (x_1, x_2, x_3, x_4) = (r, ict)$$

(1) **Position four - vector**  $x_\mu$  - It is expressed as

$$x_\mu = (x_1, x_2, x_3, x_4) = (r, ict)$$

(2) **Four - velocity or velocity four - vector**  $u_\mu$  - The components of the velocity four - vector  $u_\mu$  are defined as:

$$u_1 = \frac{dx_1}{d\tau} = \frac{dx_1}{dt} \frac{dt}{d\tau} = \frac{dx}{dt} \frac{1}{\sqrt{1-u^2/c^2}} = \frac{u_x}{\sqrt{1-u^2/c^2}}$$

$$u_2 = \frac{dx_2}{d\tau} = \frac{dx_2}{dt} \frac{dt}{d\tau} = \frac{dy}{dt} \frac{1}{\sqrt{1-u^2/c^2}} = \frac{u_y}{\sqrt{1-u^2/c^2}}$$

$$u_3 = \frac{dx_3}{d\tau} = \frac{dx_3}{dt} \frac{dt}{d\tau} = \frac{dz}{dt} \frac{1}{\sqrt{1-u^2/c^2}} = \frac{u_z}{\sqrt{1-u^2/c^2}}$$

$$u_4 = \frac{dx_4}{d\tau} = \frac{d(ict)}{dt} \frac{dt}{d\tau} = \frac{ic}{\sqrt{1-u^2/c^2}}$$

i.e. 
$$u_\mu = \left( \frac{\mathbf{u}}{\sqrt{1-u^2/c^2}}, \frac{ic}{\sqrt{1-u^2/c^2}} \right)$$

Where  $\mathbf{u} = d\mathbf{r}/dt$  is the three dimensional velocity vector.

The square of the magnitude of the velocity four vector is given by

$$u_\mu u_\mu = \frac{u^2}{1-u^2/c^2} - \frac{c^2}{1-u^2/c^2} = -c^2$$

This is Lorentz invariant.

**(3) Momentum four vector  $p_\mu$**  : The components of four - momentum  $p_\mu$  are defined by

$$p_1 = m_0 u_1 = \frac{m_0 u_x}{\sqrt{1-u^2/c^2}} = m u_x = p_x$$

$$p_2 = m_0 u_2 = \frac{m_0 u_y}{\sqrt{1-u^2/c^2}} = m u_y = p_y$$

$$p_3 = m_0 u_3 = \frac{m_0 u_z}{\sqrt{1-u^2/c^2}} = m u_z = p_z$$

$$p_4 = m_0 u_4 = \frac{m_0 ic}{\sqrt{1-u^2/c^2}} = imc = i \frac{E}{c}$$

$$p_\mu = (p_1, p_2, p_3, p_4) = (p_x, p_y, p_z, imc) = (\mathbf{p}, iE/c) \text{ with } \mathbf{p} = m\mathbf{u}$$

The square of the magnitude of the four - momentum is given by

$$p_\mu p_\mu = P^2 - \frac{E^2}{c^2} = -(E^2 - p^2 c^2)/c^2 \text{ or } p_\mu p_\mu = -m_0^2 c^2$$

This  $p_\mu$  is also called **energy - momentum four - vector**

### MASS- ENERGY RELATION:

**(Equation of Energy in Relativistic Mechanics)**

Force is defined as rate of change of linear momentum,

i.e. 
$$F = \frac{d}{dt}(m v)$$



According to the definition of kinetic energy, we know that kinetic energy of a moving body is equal to work done by the force that imparts the velocity to the body from rest, therefore we have kinetic energy,

$$\begin{aligned} T &= \int_{v=0}^{v} F ds = \int_0^v \frac{d}{dt}(mv) ds \\ &= \int_0^v d(mv) \frac{ds}{dt} \quad \left( \text{Since } \frac{ds}{dt} = v \right) \\ &= \int_0^v v d(mv) \end{aligned}$$

According to theory of relativity

$$m = \frac{m_0}{\sqrt{1 - \frac{v^2}{c^2}}}$$

Kinetic energy

$$T = \int_0^v v d \left\{ \frac{m_0}{\sqrt{1 - \frac{v^2}{c^2}}} v \right\}$$

By solving

$$= (m - m_0) c^2.$$

Kinetic energy,

$$T = (m - m_0) c^2. \quad \dots (1)$$

This is **kinetic energy equation, in relativistic mechanics.**

For low velocities this reduces to ordinary expression for kinetic energy, i.e.,

$$T = \frac{1}{2} m_0 v^2 \text{ for } v \ll c$$

Equation (1) represents that the kinetic energy of a moving body is equal to gain in mass due to its motion times  $c^2$ . This suggests that the increase in energy may be considered as the actual case of the increase in mass. Then we may suppose that the rest mass  $m_0$  is due to the presence of an internal store of energy of a moving body is given by.

$$E = \text{kinetic energy} + \text{rest energy}$$

$$= (m - m_0) c^2 + m_0 c^2$$

Or

$$E = mc^2$$

This is Einstein's famous mass - energy relation and states a *universal equivalence between mass and energy*.

## POINTS TO REMEMBER

### 1. Galilean Transformation

At any instant, the coordinates of a point or particle in space will be different in different coordinate systems. The equations which provide the relationship between the coordinates of two reference systems are called transformation equation.

$$x' = x - vt, \quad y' = y, \quad z' = z, \quad t' = t$$

These are Galilean Transformation.

### 2. Postulates of special theory of relativity

- (i) All the laws of physics have the same form in all inertial systems, moving with constant velocity relative to one another
- (ii) The speed of light is constant in vacuum in every inertial system.

### 3. Lorentz transformation

$$x' = \frac{x - vt}{\sqrt{1 - \frac{v^2}{c^2}}}$$

$$y' = y$$

$$z' = z$$

$$t' = \frac{t - \frac{vx}{c^2}}{\sqrt{1 - \frac{v^2}{c^2}}}$$

#### (i) Length contraction (Lorentz – Fitzgerald contraction)

$$l = l_0 \sqrt{1 - \frac{v^2}{c^2}}$$

Where  $l_0 \rightarrow$  proper length

(ii) **Simultaneity:** If two events occur at the same time in a frame, they are said to be simultaneous.

$$t'_2 - t'_1 = -\frac{\left(\frac{v}{c^2}\right)(x_2 - x_1)}{\sqrt{1 - \frac{v^2}{c^2}}}$$

(iii) **Time Dilation:**  $\Delta t = \frac{\Delta t_0}{\sqrt{1 - \frac{v^2}{c^2}}}$

Where  $\Delta t_0 \rightarrow$  proper time interval.

#### 4. Four Vectors

(i) Position four vector ( $x_\mu$ ).  $x_\mu = (r, ict)$

(ii) Velocity four-vector ( $u_\mu$ )

$$u_\mu = \left( \frac{u}{\sqrt{1 - \frac{u^2}{c^2}}}, \frac{ic}{\sqrt{1 - \frac{u^2}{c^2}}} \right)$$

(iii) Momentum four vector ( $p_\mu$ )

$$p_\mu = \left( p, \frac{iE}{c} \right)$$

#### 5. Mass-Energy relation

Kinetic energy  $T = (m - m_0)c^2$

Total energy  $E = \text{K.E.} + \text{rest mass energy}$

$$= (m - m_0)c^2 + m_0c^2$$

$$= mc^2$$

This is Einstein's famous mass energy relationship.

**6. Relativistic relation between momentum and energy is**

$$E^2 = p^2c^2 + m_0^2c^4$$

**SOME PROBLEMS**

- A particle has a velocity  $6 \times 10^7$  m/sec in the X-Y plane at angle of  $60^\circ$  with X-axis in the system S. What is the velocity in the system S'. When S' has a velocity  $3 \times 10^7$  m/sec along the positive X-axis.  
 (1)  $5.2 \times 10^7 \hat{i}$       (2)  $5.2 \times 10^7 \hat{j}$       (3)  $5.2 \times 10^7 \hat{k}$       (4)  $6.2 \times 10^7 \hat{i}$
- When an observer moves so fast that the lengths that he measures are reduced to half, his time interval measurements.  
 (1) Be invariant      (2) Reduced to half      (3) Becomes twice      (4) Reduced to  $\frac{1}{4}$ th
- Rest mass energy of an electron is 0.51 MeV. A moving electron has a kinetic energy of 9.69 MeV. The ratio of the mass of the moving electron to its mass is  
 (1) 19 : 1      (2) 20 : 1      (3) 1 : 19      (4) 1 : 20
- A rapidly moving sphere will be observed as  
 (1) Contracted longitudinally as ellipsoid      (2) Merely rotated, but the same size  
 (3) un-rotated and of the same size.      (4) None of these
- A particle of rest mass  $m_0$  moving with a speed of  $6c$  collides and sticks to a similar particle initially at rest. What are the rest mass and velocity of the composite particle?  
 (1)  $2.12 m_0, 1.333 c$       (2)  $4.12 m_0, .333 c$       (3)  $4.12 m_0, 1.333 c$       (4)  $2.12 m_0, .333 c$

**ANSWER KEY** 1. (2), 2. (3), 3. (2), 4. (1), 5. (4)

1. (2) The x and y components of the Velocity in S' frame are given by

$$u'_x = \frac{u_x - v}{1 - u_x v / c^2}, \quad u'_y = \frac{u_y \sqrt{1 - v^2 / c^2}}{(1 - u_x v / c^2)}$$

Here,  $u_x = 6 \times 10^7 \cos 60^\circ = 3 \times 10^7 \text{ m/sec}$ ,  $6 \times 10^7 \sin 60^\circ = 3\sqrt{3} \times 10^7 \text{ m/sec}$  and  $v = 3 \times 10^7 \text{ m/sec}$ .

$$\text{Therefore } u'_x = \frac{3 \times 10^7 - 3 \times 10^7}{1 - \frac{3 \times 10^7 \times 3 \times 10^7}{(3 \times 10^8)^2}} = 0$$

$$\begin{aligned} \text{Also, } u'_y &= \sqrt{1 - \left[ \frac{3 \times 10^7}{3 \times 10^8} \right]^2} \times \left[ \frac{3\sqrt{3} \times 10^7}{1 - \frac{3 \times 10^7 \times 3 \times 10^7}{(3 \times 10^8)^2}} \right] \\ &= \sqrt{\frac{99}{100}} \times \frac{3\sqrt{3} \times 10^7 \times 100}{99} = \sqrt{\frac{3}{11}} \times 10^8 = 5.2 \times 10^7 \text{ m/sec} \end{aligned}$$

Hence the velocity in S' frame is

$$\mathbf{u}' = 0 \hat{i} + 5.2 \times 10^7 \hat{j} \quad \text{or} \quad u' = 5.2 \times 10^7 \hat{j}$$

This means that the particle will appear to an observer in S' to be moving along the Y-axis with velocity  $5.2 \times 10^7 \text{ m/sec}$ .

2. (3) In Lorentz transformation, by Length Contraction method the observed length is

$$L = L_0 \sqrt{1 - \frac{v^2}{c^2}} \quad \dots\dots (1)$$

$L_0 \rightarrow$  proper length

According to question

$$L = \frac{L_0}{2}$$

$$\text{So, from eq (1) } \frac{L_0}{2} = L_0 \sqrt{1 - \frac{v^2}{c^2}}$$

$$\sqrt{1 - \frac{v^2}{c^2}} = \frac{1}{2} \quad \dots\dots(2)$$

By time dilation method the observed time interval is  $\tau = \frac{\tau_0}{\sqrt{1 - \frac{v^2}{c^2}}}$  ....(3)

$\tau_0 \rightarrow$  Proper time interval from eq. (2) & (3)

$$\tau = 2\tau_0$$

So, observed time interval becomes twice.

3. (2) Given rest mass energy  $E_R = m_0c^2 = 0.51\text{Mev}$

And kinetic energy  $T = 9.69\text{Mev}$ .

We know from Einstein Theory

$$E = mc^2 = \text{K.E.} + \text{rest mass energy}$$

$$mc^2 = T + m_0c^2$$

$$\frac{mc^2}{m_0c^2} = \frac{T}{m_0c^2} + 1$$

$$\frac{m}{m_0} = 1 + \frac{T}{m_0c^2} = 1 + \frac{9.69}{0.51}$$

$$\frac{m}{m_0} = 1 + 19 = 20$$

$$m : m_0 = 20 : 1$$

4. (1) The equation of sphere is  $x^2 + y^2 = a^2$

We know Lorentz transformation equation

$$x' = \gamma(x - vt)$$

$$y' = y, \quad z' = z$$

$$t' = \gamma \left[ t - \frac{v}{c^2}x \right]$$

Where  $\gamma = \frac{1}{\sqrt{1 - \frac{v^2}{c^2}}}$

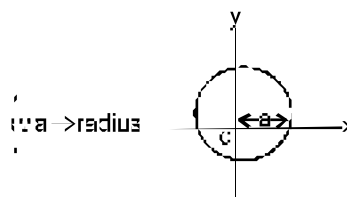

When sphere is moving then in moving frame it's equation become as

$$x^2 + y^2 = a^2$$

$$\gamma^2(x - vt)^2 + y^2 = a^2$$

$$\frac{(x - vt)^2}{\frac{a^2}{\gamma^2}} + \frac{y^2}{a^2} = 1$$

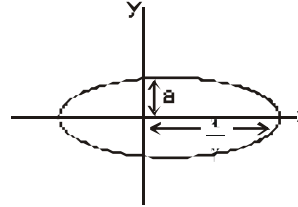

This is the equation of ellipsoid. Where length of semi major axis is  $\frac{a}{\gamma}$  and semi minor axis is  $a$ .

5. (4) since law of conservation of momentum is

$$\frac{M_0 V}{\sqrt{1 - \frac{v^2}{c^2}}} = \frac{m_0 \times .6c}{\sqrt{1 - (.6)^{-2}}} = \frac{3}{4} m_0 c \quad \dots(1)$$

$M_0$  is rest mass of the composite body and  $m_0$  is rest mass of particle and  $v$  is velocity of composite particle.

Now using mass energy equivalence

$$\begin{aligned} \frac{M_0 c^2}{\sqrt{1 - \frac{v^2}{c^2}}} &= \frac{m_0 c^2}{\sqrt{1 - \frac{v^2}{c^2}}} + m_0 c^2 \\ &= \frac{m_0 c^2}{\sqrt{1 - \frac{(.6c)^2}{c^2}}} + m_0 c^2 = \frac{m_0 c^2}{8} + m_0 c^2 \end{aligned}$$

$$= m_0 c^2 \left[ \frac{9}{8} + 1 \right]$$

$$= m_0 c^2 \left[ \frac{17}{8} \right]$$

$$\frac{M_0 c^2}{1 - \frac{v^2}{c^2}} = \frac{17}{8} m_0 c^2 \quad \dots(2)$$

$\frac{\text{equation 1}}{\text{equation 2}}$  Then

$$\frac{v}{c^2} = \frac{\frac{3}{4}m_0c}{\frac{9}{4}m_0c^2} \Rightarrow \frac{v}{c^2} = \frac{1}{3c} \Rightarrow v = \frac{c}{3}$$

$$v = .333 c$$

then using equation (2)

$$\frac{M_0c/3}{\sqrt{1 - \frac{c^2}{9} \times \frac{1}{c^2}}} = \frac{3}{4}m_0\ell$$

$$\frac{M_0}{3\sqrt{1 - \frac{1}{9}}} = \frac{3}{4}m_0$$

$$\frac{M_0}{\sqrt{9 - 1}} = \frac{3}{4}m_0$$

$$M_0 = \frac{3}{4}\sqrt{8}m_0$$