

IIT JAM - PHYSICS

SAMPLE THEORY

MECHANICS, OPTICS AND ELECTRONICS

- NEWTON'S LAW OF MOTION
- POLARIZATION
- P-N- JUNCTION

VPM CLASSES

For IIT-JAM, JNU, GATE, NET, NIMCET and Other Entrance Exams

1-C-8, Sheela Chowdhary Road, Talwandi, Kota (Raj.) Tel No. 0744-2429714

Web Site www.vpmclasses.com E-mail vpmclasses@yahoo.com

Phone: 0744-2429714

Website: www.vpmclasses.com

Address: 1-C-8, Sheela Chowdhary Road, SFS, TALWANDI, KOTA, RAJASTHAN, 324005

Mobile: 9001297111, 9829567114, 9001297243

E-Mail: vpmclasses@yahoo.com / info@vpmclasses.com

INTRODUCTION

Mechanics is a branch of physics which deals with physical objects in motion and at rest under the influence of external and internal interactions. Mechanics had developed since ancient times on the basis of observations on the motion of material particles. The mechanics based on Newton's laws of motion and alternatively developed by Lagrange, Hamilton and others is called **classical mechanics**. When this mechanics deals with the Newton's laws and their consequences, it may be called as **Newtonian or vectorial mechanics**, because in this scheme, the quantities such as force, acceleration, momentum etc. are used which are essentially vectors".

Space and time :

We have some idea about the meaning of space and time. It is assumed (i) that the space and time are continuous, (ii) that the motion of a particle in space can be described by knowing its position at different instants of time, and (iii) that there are universal standards of length and time. S.I. unit of measurement of length and time are meter and second respectively.

If we imagine a coordinate system attached to a rigid body and we describe the position of any particle relative to it, then such a coordinate system is called **frame of reference**.

NEWTON'S LAWS OF MOTION

Newton's laws of motion are stated in the following form:

- (i) "Every body continues to be in its state of rest or of uniform motion in a straight line unless it is compelled to change that state by external forces acting on it."
- (ii) "The time rate of change of momentum of particle is proportional to the external force and is in the direction of the force ."
- (iii) "To every action there is always an equal and opposite reaction" or "the mutual actions of any two bodies are always equal and oppositely directed along the same straight line".

Newton's first law of motion tells us about the motion of a body when no force acts on it. This law does not tell us what the force does; but it simply tells us what happens when it is absent. One can interpret the first law as the definition of 'zero force'.

The meaning of the force in terms of the momentum

$$p = mv$$

is given by Newton's second law which can be expressed as

$$F \propto \frac{dp}{dt}$$

where $m \rightarrow$ mass of particle

$v \rightarrow$ velocity

$t \rightarrow$ time

$p \rightarrow$ momentum

or
$$F = k \frac{dp}{dt} = k \frac{d}{dt}(mv) = km \frac{dv}{dt}$$

where k is the constant of proportionality. This constant can be chosen to be equal to unity by defining the unity of the force as that force which while acting on a body of unit mass produces a unit acceleration.

Force :

That physical parameter which produces or tends to produce an acceleration in a particle, is defined as **force**.

Unit of force - Newton in MKS system

dyne in CGS system

$$1 \text{ newton} = 10^5 \text{ dyne}$$

$$\text{Dimensions of force} - M^1 L^1 T^{-2}$$

Result of force applied in various states :

(i) 

Fig. (1)

In case (Fig.1) only the magnitude of velocity of the particle changes whereas its direction remains same.

Consequently the path of particle is a straight line.

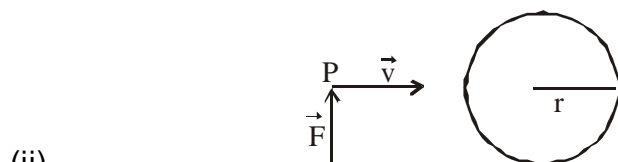

Fig (2)

In case (Fig.2) only the direction of velocity of the particle changes whereas its magnitude remains constant. Consequently the path of the particle is a circle.

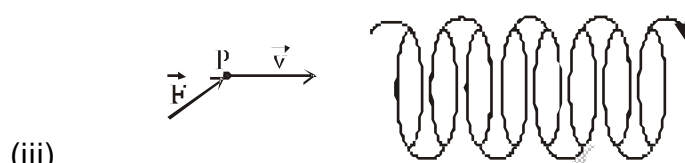

Fig (3)

In case (Fig.3) both the magnitude as well as direction of velocity of the particle change. Consequently the path of motion of the particle is a helix.

NEWTON'S EQUATION OF MOTION

I st equations	$V = u + at$
II nd equation	$S = ut + \frac{1}{2}at^2$
III rd equation	$V^2 = U^2 + 2as$

where $u \rightarrow$ initial velocity

$v \rightarrow$ final velocity

$t \rightarrow$ time

$a \rightarrow$ acceleration

$s \rightarrow$ distance travel by particle

Ex. A golf ball of mass 0.05 kg placed on a tree, is struck by a golf club. The speed of the golf ball as it leaves the tree is 100 m/s, then time of contact between them is 0.02 s. The force at the beginning of the contact is

- (A) 500 N (B) 250 N (C) 200 N (D) 100 N

Sol.(A) Since, force decreases to zero within 0.02 s and is linear with time, hence force $\propto (0.02-t)$

$$\Rightarrow F = k(0.02-t) \text{ where } k \text{ is constant} \quad \dots(i)$$

$$\Rightarrow \text{Change in momentum} = \text{impulse} \quad \Rightarrow \quad mu = \int_0^{0.02} k(0.02-t) dt = k \left(0.02t - \frac{t^2}{2} \right)$$

$$= k \left[(0.02)(0.02) - \frac{(0.02)^2}{2} \right]$$

$$\Rightarrow 5 = k \frac{[(0.02) \times (0.02)]}{2} \Rightarrow 10 = k \times 4 \times 10^{-4} \Rightarrow k = 25000 \quad \dots(ii)$$

$$\text{By. Eqs. (i) and (ii), Force } F = k(0.02-t) \Rightarrow F = 25000(0.02-t)$$

$$\Rightarrow \text{at initial, } t = 0 \Rightarrow F = 25000(0.02) \Rightarrow 500 \text{ N}$$

Ex . A particle is moving in space with 0 as the origin. Some possible expressions for its , velocity and acceleration in cylindrical coordinates (ρ, ϕ, z) are given below , which one of these is correct ?

$$(A) , \quad \vec{v} = \frac{d\rho}{dt} \hat{e}_\rho + \frac{\rho d\phi}{dt} \hat{e}_\phi + \frac{dz}{dt} \hat{e}_z, \vec{a} = \frac{d^2\rho}{dt^2} \hat{e}_\rho + \frac{d}{dt} \left(\frac{\rho d\phi}{dt} \hat{e}_\phi \right) + \frac{d^2z}{dt^2} \hat{e}_z$$

$$(B) , \quad \vec{v} = \frac{d\rho}{dt} \hat{e}_\rho + \frac{d}{dt} (\rho\phi \hat{e}_\phi) + \frac{dz}{dt} \hat{e}_z, \vec{a} = \left(\frac{d^2\rho}{dt^2} - \rho \left(\frac{d\phi}{dt} \right)^2 \right) \hat{e}_\rho + \left(\frac{\rho d\phi}{dt^2} + \frac{2d\rho}{dt} \frac{d\phi}{dt} \right) \hat{e}_\phi$$

$$(C) , \quad \vec{v} = \frac{d\rho}{dt} \hat{e}_\rho + \frac{\rho d\phi}{dt} \hat{e}_\phi + \frac{dz}{dt} \hat{e}_z, \vec{a} = \left[\frac{d^2\rho}{dt^2} - \rho \left(\frac{d\phi}{dt} \right)^2 \right] \hat{e}_\rho + \left(\frac{\rho d^2\phi}{dt^2} + \frac{2d\rho}{dt} \frac{d\phi}{dt} \right) \hat{e}_\phi + \frac{d^2z}{dt^2} \hat{e}_z$$

$$(D) \vec{v} = \dot{\rho} \hat{e}_\rho + \dot{\phi} \hat{e}_\phi + \dot{z} \hat{e}_z, \vec{a} = (\ddot{\rho} - \rho\dot{\phi}^2) \hat{e}_\rho + (\rho\ddot{\phi} + 2\dot{\rho}\dot{\phi}) \hat{e}_\phi + \ddot{z} \hat{e}_z$$

Sol.(C) We know cylindrical coordinate is

$$\vec{r} = \rho \hat{e}_\rho + z \hat{e}_z$$

and velocity $\vec{v} = \dot{r} = \dot{\rho}\hat{e}_\rho + \rho\dot{\hat{e}}_\rho + \dot{z}\hat{e}_z$

$$\vec{v} = \dot{\rho}\hat{e}_\rho + \rho\dot{\hat{e}}_\rho + \dot{z}\hat{e}_z \quad \left[\dot{\hat{e}}_\rho = \dot{\phi}\hat{e}_\phi \right]$$

similarly acceleration

$$\vec{a} = \dot{v} = \ddot{\rho}\hat{e}_\rho + \dot{\rho}\dot{\hat{e}}_\rho + \dot{\rho}\dot{\phi}\hat{e}_\phi + \rho\ddot{\phi}\hat{e}_\phi + \rho\dot{\phi}\dot{\hat{e}}_\rho + \ddot{z}\hat{e}_z \quad \left[\dot{\hat{e}}_\phi = -\dot{\phi}\hat{e}_\rho \right]$$

$$\vec{a} = (\ddot{\rho} - \rho\dot{\phi}^2)\hat{e}_\rho + (\rho\ddot{\phi} + 2\dot{\rho}\dot{\phi})\hat{e}_\phi + \ddot{z}\hat{e}_z$$

POLARIZATION OF LIGHT

- Light waves are electromagnetic waves in which electric and magnetic field vectors vary sinusoidally mutually perpendicular to each other as well as perpendicular to the direction of propagation of light wave. The electric vector determines the nature of polarisation.

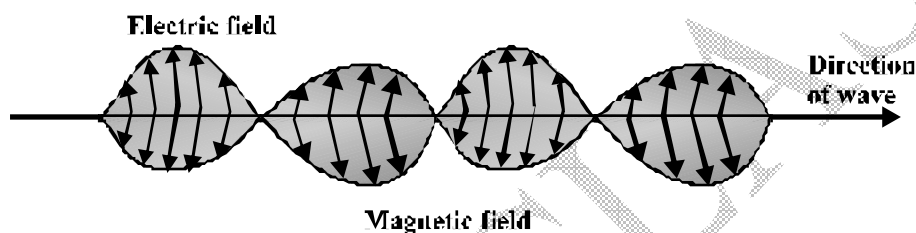

Fig. (1) The electric and magnetic fields are perpendicular to each other and to the direction of the wave

- In ordinary light, the vibrations of electric vector are distributed in all directions in a plane (Y-Z plane), perpendicular to the direction of propagation of light wave (X- direction).
- These vibrations of electric vector can be supposed to be made up of two mutually perpendicular vibrations, one in the plane of paper, and other vibrations a direction perpendicular to the plane of paper.

Unpolarized light

Whenever the vibrations in a light wave occur in all possible direction including normal to the direction of propagation, then such a light is termed as unpolarised wave, and the light is known as unpolarised light. In general, light emitted by ordinary sources is unpolarised, because light emitting atoms are large in number. Each such atom emits light wave after

every 10^{-8} sec. Therefore, a large number of waves are produced every second. Light emitted by every atom has varying polarisation, it means that after every 10^{-8} sec, the polarisation changes.

Polarizer

The device (natural or artificial), which limits the vibrations of electric vector in natural (unpolarised) light in only one direction in a plane perpendicular to the direction of propagation of light wave, when passed through it, is known as polarizer.

Analyser

The device (polarizer - natural or artificial), which detects whether any given light is polarized light or unpolarized light, is known as analyser.

Plane of vibration

The plane containing the direction of propagation and direction of vibration is known as plane of vibration.

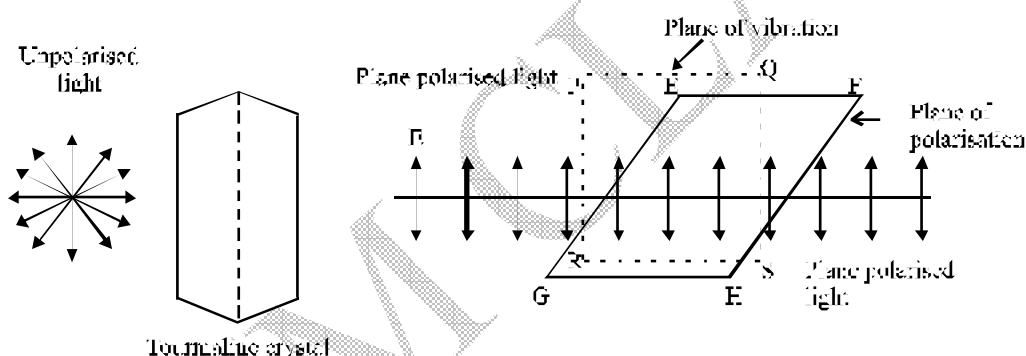

Fig. (2) "Plane of polarisation and plane of vibration"

- **Plane of polarization**

The plane which passes through the direction of propagation of light and which contains no vibration (not any electric vector \vec{E}) known as **plane of polarisation**.

- **Representation of polarized light**

- Unpolarized light consists of a very large number of vibrations in all planes with equal probability at right angles to the direction of propagation. Hence unpolarized light is represented by star.

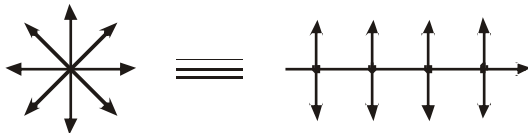

Fig. (3)

- In polarized light the vibrations of electric vector are confined to only one direction perpendicular to the direction of wave propagation.
- If the vibrations of electric vector are parallel to the plane of paper then polarized light is said “**vertically polarised**” and represented by arrows.

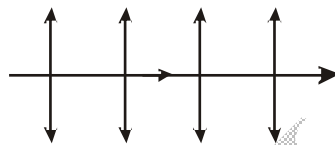

Fig. (4)

- If the vibrations of electric vector are perpendicular to the plane of paper then polarized light is said “**horizontally polarised**” and represented by dots.



Fig. (5)

Types of polarization

The equation of transverse E.M. wave is written as

$$\vec{E} = [\hat{x} E_1^0 e^{i\alpha_1} + \hat{y} E_2^0 e^{i\alpha_2}] \exp i(kz - \omega t)$$

where $E_1^0, E_2^0 \rightarrow$ real value of amplitude of electric field vector $\alpha_1, \alpha_2 \rightarrow$ phase factors

The polarization of light is shown by electric field vector.

(i) Plane polarized light :

When the amplitude component E_1^0 and E_2^0 are in same phase and the phase difference between them are the whole multiple of π . i.e.

$$\alpha_2 - \alpha_1 = \pm m\pi \quad \text{where } m = 0, 1, 2, 3 \dots$$

So, the equation of E.M. wave is

$$\vec{E} = [\hat{x} E_1^0 + \hat{y} E_2^0] \exp i [kz - \omega t + a_1]$$

Then this type of E.M. wave is called "plane polarized light (wave)."

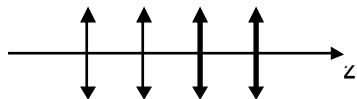

Vertically polarised light

(A)

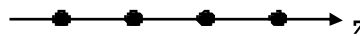

Horizontally polarised light

(B)

Fig.6

(ii) Circularly polarised light :

If both component of amplitude E_0 of electric field vector are real and equal, but have phase different $\pm \pi/2$, i.e.

$$E_1^0 = E_2^0 = E^0$$

$$\alpha_2 = \alpha_1 \pm \pi/2$$

$$\text{then } \vec{E} = E^0 [\hat{x} \pm i\hat{y}] \exp i (kz - \omega t + \alpha_1)$$

Then this type of E.M. wave is called "Circularly Polarised wave"

$$E^2 = E_x^2 + E_y^2$$

where

$$E_x = E^0 \cos [kz - \omega t + \alpha_1]$$

$$E_y = E^0 \sin [kz - \omega t + \alpha_1]$$

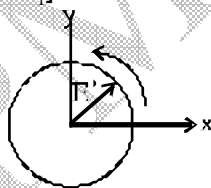

Left handed circularly polarised
L - circularly

(A)

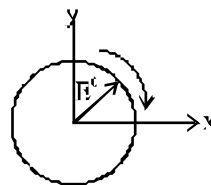

Right handed circularly polarised
R - circularly

(B)

Fig. (7)

(iii) Elliptically Polarised Light

When the phase difference between two component E_1^0 & E_2^0 of E^0 is $\pm \pi/2$ and they are not equal in magnitude, i.e.

$$\alpha_2 = \alpha_1 \pm \frac{\pi}{2}$$

$$E_1^0 \neq E_2^0$$

then

$$\vec{E} = [\hat{x} E_1^0 \pm i \hat{y} E_2^0] \exp i(kz - \omega t + \alpha_1)$$

and
$$\frac{E_x^2}{(E_1^0)^2} + \frac{E_y^2}{(E_2^0)^2} = 1$$

This Type of E.M. wave is called “**elliptically polarized light**”.

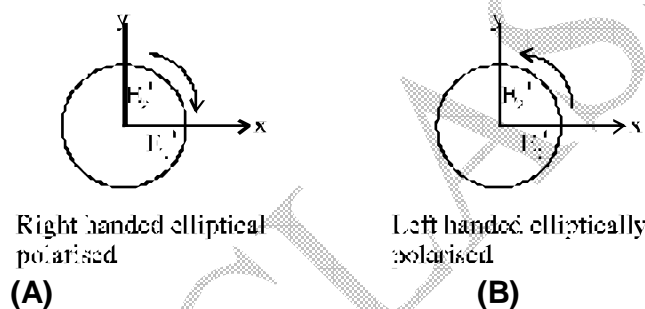

Fig. (8)

Production of Plane Polarised Light

- | | |
|---|---------------------------------|
| (i) Polarisation by reflection | (ii) Polarisation by refraction |
| (iii) Polarisation by double-refraction | (iv) Polarisation by dichorism |
| (v) Polarisation by scattering | |

Polarisation by reflection : Brewster's law :

If we allow ordinary light (unpolarised) to fall on a glass plate (not mirror) and examine the reflected light through a polaroid or tourmaline crystal, we find that the reflected light is polarised. When the angle of incidence is changed, we find that for a particular value of the angle of incidence, the intensity of two minima (coming out of polaroid) reduces to zero. In

this situation the light ray reflected from glass plate is completely plane polarised. This particular angle of incidence i_p is known as **Polarising angle or Brewster's angle**.

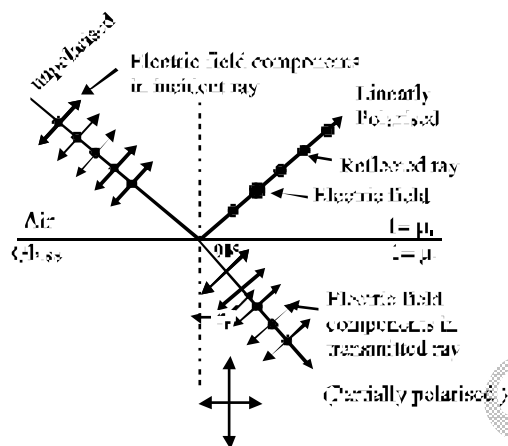

Fig. (9) Brewster's law at polarising angle

Brewster determined this angle (angle of polarisation) for different reflecting surfaces and established a relation between polarising angle i_p (angle of incidence) and the refractive index of the material at which incidence of light takes place. This relation is

$$\mu = \tan i_p \quad \dots(1)$$

It is also known as Brewster's Law. Brewster also proved that at polarising angle i_p , the reflected and refracted beams are mutually at right angle. This is clear from the following.:

Snell's law $\mu = \frac{\sin i}{\sin r}$

if $i = i_p$ (Brewster's angle)

then $\mu = \tan i_p = \frac{\sin i_p}{\cos i_p}$

$\therefore \frac{\sin i_p}{\cos i_p} = \frac{\sin i_p}{\sin r_p}$

or $\sin r_p = \cos i_p = \sin (90^\circ - i_p)$

$r_p = 90^\circ - i_p \quad \therefore r_p + i_p = 90^\circ \quad \dots(2)$

Note that Eq. (2) is true for reflection at any transparent medium and not mirrors.

Ex. $\vec{E}(x, y, z, t) = A(3\hat{i} + 4\hat{j}) \exp[i(\omega t - kz)]$ represents an electromagnetic wave. Possible directions of the fast axis of a quarter wave plate which converts this wave into a circularly polarized wave are

(A) $\frac{1}{\sqrt{2}}[7\hat{i} + \hat{j}]$ and $\frac{1}{\sqrt{2}}[-\hat{i} + 7\hat{j}]$

(B) $\frac{1}{\sqrt{2}}[3\hat{i} + 4\hat{j}]$ and $\frac{1}{\sqrt{2}}[4\hat{i} - 3\hat{j}]$

(C) $\frac{1}{\sqrt{2}}[3\hat{i} - 4\hat{j}]$ and $\frac{1}{\sqrt{2}}[4\hat{i} + 3\hat{j}]$

(D) $\frac{1}{\sqrt{2}}[7\hat{i} - \hat{j}]$ and $\frac{1}{\sqrt{2}}[\hat{i} + 7\hat{j}]$

Sol.(B) $\vec{E}(x, y, z, t) = A(3\hat{i} + 4\hat{j}) \exp[i(\omega t - kz)]$

possible directions of the fast axis of a quarter wave plate is

$$\frac{1}{\sqrt{2}}(3\hat{i} + 4\hat{j}) \text{ and } \frac{1}{\sqrt{2}}(4\hat{i} - 3\hat{j})$$

which converts this wave into a circularly polarized wave.

Ex. A beam of plane polarised light is incident normally on a polariser (cross-sectional area $3 \times 10^{-4} \text{ m}^2$) which rotates about the axis of the ray with an angular velocity of 31.4 rad/s . Find the intensity of emergent beam and the energy of light passing through the polariser per revolution if flux of energy of incident ray is 10^{-3} watt .

Sol. If at any instant the axis of a polariser subtends an angle θ with the direction of vibration of incident light, the intensity of emergent light in accordance with Malus law will be

$$I = I_0 \cos^2 \theta$$

As here the polariser is rotating, i.e., all values of θ are possible,

$$I_{av} = \frac{1}{2\pi} \int_0^{2\pi} I d\theta = \frac{1}{2\pi} \int_0^{2\pi} I_0 \cos^2 \theta d\theta$$

i.e.,
$$I_{av} = \frac{I_0}{2\pi} \times \frac{1}{2} \int_0^{2\pi} (1 + \cos 2\theta) d\theta$$

i.e.,
$$I_{av} = \frac{I_0}{2\pi} \times \frac{1}{2} \left[\theta + \frac{1}{2} \sin 2\theta \right]_0^{2\pi} = \frac{1}{2} I_0$$

But as
$$I_0 = \frac{\text{Energy}}{\text{Area} \times \text{Time}} = \frac{\text{Power}}{\text{Area}} = \frac{10^{-3}}{3 \times 10^{-4}} = \frac{10}{3} \text{ W m}^2$$

so,
$$I_{av} = \frac{1}{2} \left(\frac{10}{3} \right) = \frac{5}{3} \frac{W}{m^2}$$

Now as time period of one revolution,

$$T = \frac{2\pi}{\omega} = \frac{2 \times 3.14}{31.4} = \frac{1}{5} \text{ S}$$

So energy of light passing through the polariser per revolution

$$= I_{av} \times \text{area} \times T$$

$$= \frac{5}{3} \times 3 \times 10^{-4} \times \frac{1}{5} = 10^{-4} \frac{J}{\text{rev}}$$

SEMICONDUCTOR DEVICES: THE P-N JUNCTION DIODE

A P-N junction can be formed by taking a slice of Si or Ge crystal and doping it with trivalent impurity in one half and with a pentavalent impurity in the other half. The charge carriers in the two regions move about in a random manner and will diffuse from a region of high concentration to a region of low concentration. Thus some of the free electrons from the N-region diffuse into the P-region while some holes from the P-region diffuse into the N-region. In a small region on either side of the junction there is an appreciable chance for the electrons to fall into the holes and thereby completing the covalent bonds. Such a recombination of electrons and holes results in the removal of charge carriers from the narrow region around the junction. The ionised acceptor atoms (A) are almost immobile however (negative ions) which are almost immobile

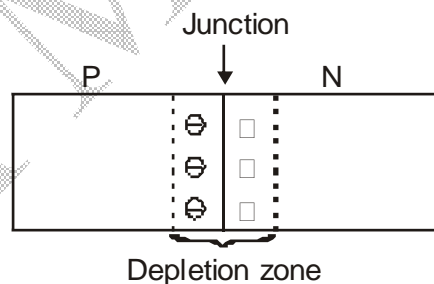

Fig.1

however remain on the p- side of the junction on while the equally immobile donor atoms (positive ions) are left on the N-side. Such

a collection of electric charges of opposite on the two sides of the junction establishes an electric field in the region direction from the N-to the P-side (Fig.1). The direction of the electrons and holes across the junction. The electric field this sets up a potential barrier V_B at the junction which prevents the diffusion of majority carriers into opposite regions. The small region in the vicinity of the junction is depleted of charge carriers (electrons and holes) and only has the immobile ions. This region is called the depletion zone. It is only a few microns in width. Thus a P–N junction diode has the following configuration (Fig.2).

On the P-side, there are (i) fixed negative ions, (ii) the majority charge carriers (the positive holes) and (iii) the minority carriers (the negative electrons). In the depletion zone in the P-side, there are only the negative ions.

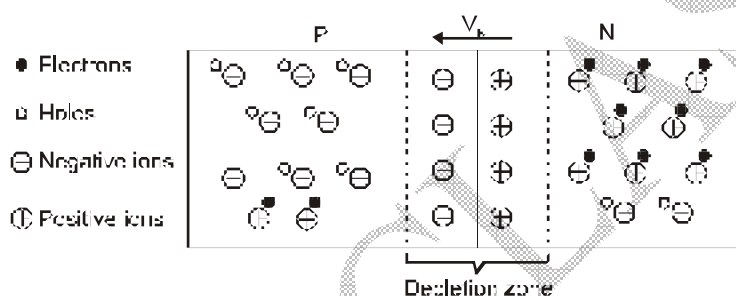

Fig2

On the N-side, there are (i) fixed positive ions, (ii) the majority carriers (the negative electrons) and (iii) the minority carriers (the positive holes). In the depletion zone on the BN-side, there are only the positive ions. The electric field setup in the depletion zone puts up a potential barrier V_B at the junction.

Forward and Reverse Biased Diode

The diode is said to be biased when an external dc source is connected across the junction. If the polarity of a voltage source V is such that it opposes the barrier, the junction is said to be forward biased (Fig.3(A)). On the other hand if the connections of the voltage source reinforce the barrier, the junction is reverse biased (Fig.47.3(B)).

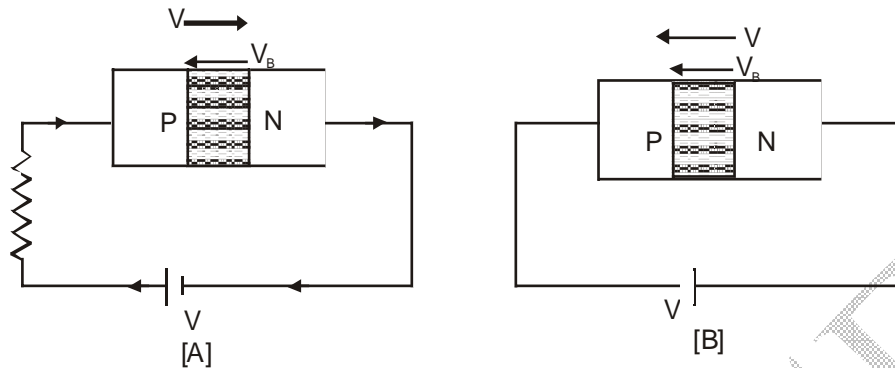

Fig.3

Forward Bias Characteristic

Under forward bias, the externally applied voltage opposes the potential barrier. With increasing forward bias, the depletion zone decreases and a small current begins to flow through the diode. With further increase in the forward bias, the barrier is almost completely overcome and the current increases rapidly. The current is of the order of milliampere and is expressed by the relation :

$$I = I_0 \left\{ \exp \left(\frac{eV}{k_B T} \right) - 1 \right\}$$

where I_0 is the reverse saturation current, k_B the Boltzmann constant and T the temperature in kelvin.

Reverse Bias Characteristic

When a junction diode is reverse biased, the externally applied voltage V adds up to the barrier voltage V_B . Thus the majority carriers (electrons in the N-region and holes in the P-region) are further pushed away from the junction. The width of the depletion zone effectively increases. However the reverse biasing aids the flow of a few minority carriers (electrons in P-region and holes in N-region) across the junction. This results in a small reverse current of the order of microamperes. This reverse current remains almost constant and increases only very little with increasing reverse bias (Fig. 4).

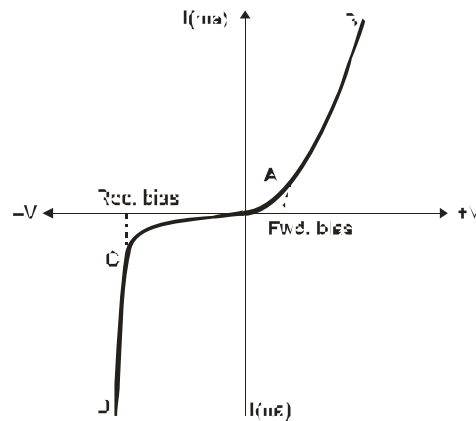

Fig.4

Avalanche Breakdown

If the reverse bias is continued to increase, the minority carriers acquire enough energy to break the covalent bonds near the junction. This liberates electron-hole pairs which also get accelerated and in turn produce more electron-hole pairs. This process rapidly multiplies and an avalanche of electron-hole pairs is generated. The reverse bias voltage at which the avalanche is produced is called the breakdown voltage.

CHARACTERISTICS OF JUNCTION DIODE

The characteristic curve of junction diode are of two types

- Static characteristic curves
- Dynamic characteristic curves
- The static and the dynamic characteristics are also of two types
 - (a)
 - Static forward characteristic curves
 - Static reverse characteristic curves
 - (b)
 - Dynamic forward characteristic curves
 - Dynamic reverse characteristic curves

Static forward characteristics

- In the absence of load resistance, the curve drawn between the forward voltage (V_f) and forward current (I_f) are known as the static forward characteristics of junction diode.

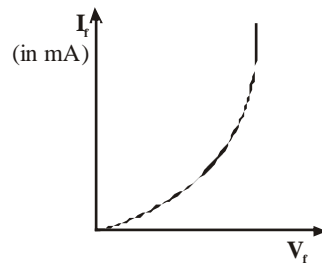

Fig.5

Static reverse characteristics

- In the absence of load resistance, the curves drawn between the reverse voltage (V_r) and reverse current (I_r) are known as the static reverse characteristics of junction diode.

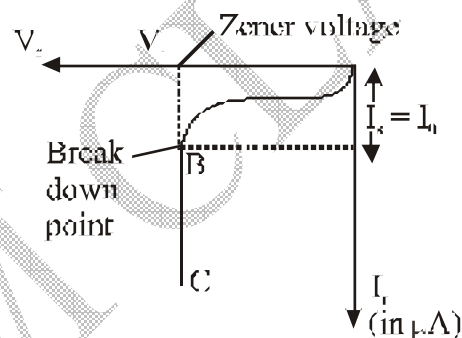

Fig.6

Static forward resistance (R_f)

- The ratio of the forward voltage (V_f) and forward current (I_f) at any point on the static forward characteristic is defined as static forward resistance of junction diode.

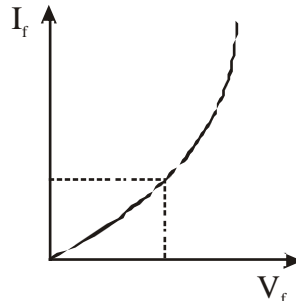

Fig.7

i.e.,

- Its value is of the order of

Static reverse resistance (R_r)

- The ratio of reverse voltage (V_r) and reverse current (I_r) at any point on static reverse characteristics is defined as the static reverse resistance of junction diode.

$$\text{i.e. } R_r = \frac{V_r}{I_r}$$

- Its value is of the order of 10^6

Dynamic forward resistance (r_f)

- The ratio of small change in forward voltage to the corresponding small change in forward current on static forward characteristics is defined as the dynamic forward resistance of junction diode (r_f).

$$r_f = \frac{\Delta V_f}{\Delta I_f} = \frac{V_{f_2} - V_{f_1}}{I_{f_2} - I_{f_1}}$$

Dynamic reverse resistance (r_r)

- The ratio of the small change in reverse voltage to the corresponding small change in reverse current on the static reverse characteristics is defined as the dynamic reverse resistance of junction diode.

$$\bullet \quad r_r = \frac{\Delta V_r}{\Delta I_r} = \frac{V_2 - V_{r1}}{I_2 - I_{r1}}$$

SYMBOL FOR A P-N JUNCTION DIODE

In an electronic circuit, the P-N junction diode is represented by the symbol shown in Fig. 8. The P-region is represented by the arrow head while the N-region is indicated by a bar. The direction of the arrow head is from P to N and symbolises the direction in which the diode conducts under forward bias. The P-side is also called the anode while the N-side is called the cathode.



Fig.8

Uses of junction diode

Junction diode can be used as a:-

- Rectifier
- Offswitch
- Condenser

Ex. A p-n junction in series with a 100 ohms resistor, is forward biased so that a current of 100 mA flows. If the voltage across this combination is instantaneously reversed to 10 V at $t = 0$, the reverse current that flows through the diode at $t = 0$ is approximately given by

- (A) 0 mA (B) 100 mA (C) 200 mA (D) 50 mA

Sol.(B) Reverse current at $t = 0$ when the voltage is instantaneously reversed to $-V_R = -10$ V is

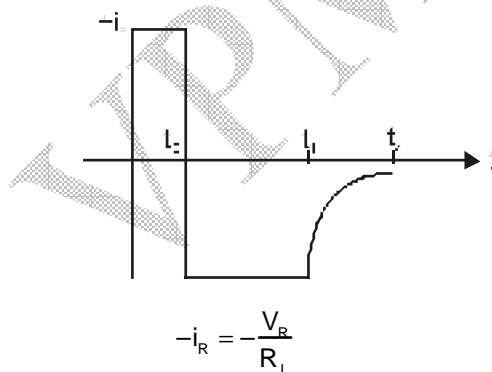

Negative sign indicating reversal of current and voltage.

$$\therefore i_R = \frac{10}{100} = 100 \text{ mA}$$

Ex. A voltage source $V_{AB} = 4 \sin \omega t$ is applied to the terminal A and B of the circuit shown in the given figure. The diodes are assumed to be ideal. The impedance by the circuit across the terminal A and B is

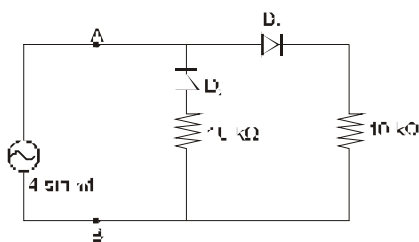

- (A) $5 \text{ k}\Omega$ (B) $10 \text{ k}\Omega$ (C) $15 \text{ k}\Omega$ (D) $20 \text{ k}\Omega$

Sol .(B) Diode D_1 conducts through $10 \text{ k}\Omega$ on the extreme right and diode D_2 is blocked. Diode D_2 conducts through the $10 \text{ k}\Omega$ in the middle branch and diode D_1 is blocked. Thus the source always sees a resistance of $10 \text{ k}\Omega$.